

110RB / 200RB / 200RH / 200RC / 240RA / 540RA

Solenoid valve



General information

RB / RA / RC and RH solenoid valve series are direct or servo actuated solenoid valves, mainly used in refrigerant control of various devices such as refrigerating and freezing systems, air conditioners and heat pumps.

Features

- Extensive selection suitable models for a wide range of refrigerant or pressure conditions
- To application conditions adapted valve design
 - 200RH series for high pressure refrigerants (R410A, R32, CO₂ subcritical),
 - 200RC series for CO₂ transcritical
- Compact size
- No disassembly necessary for brazing
- Extended copper tubes for easy installation
- Manual stems standard on 240RA20
- 240RA16T11, 240RA20 and 540RA20 are CE marked per PED
- Actuation coil and cable assemblies available for various voltages (see Technical Information ESC)
- All valves normally closed (NC); except 540RA series - normally open (NO)

NOTE: For A3 approved types, please refer to the separate document.



110RB



200RB / 200RH

Nomenclature

200	RB	-	6	T	4		Option M Manual Stem
Size Model Serie 110 / 200 / 240 (NC) 540 (NO)							
Design Series RB Standard version – smaller sizes RH High pressure version RC CO ₂ – transcritical version RA Standard Version – larger sizes							
							Connection Size in multiples of 1/8" i.e. 1/2"
							Connection type T Solder
							Seat diameter in multiples of 1/16" i.e. 3/8"

Selection Table – Valve Sizes

Type		Part No.	Connection Size		
			mm	Inch	
110RB	2	T2	801217	6	
		T2	801210		1/4
		T3	801209	10	3/8
200RB	3	T3	801239	10	
200RB	4	T3	801176	10	
		T3	801190		3/8
		T4	801178	12	
		T4	801179		1/2
200RB	6	T4	801182	12	
		T4	801183		1/2
		T5	801186	16	5/8
240RA	8	T5	801160		5/8
		T7	801143	22	7/8
240RA	9	T5	801161	16	5/8
		T7	801162	22	7/8
		T9	801144		1-1/8
240RA	12	T7	801163	22	7/8
		T9	801144		1-1/8
240RA	16	T9	801164		1-1/8
		T11	801166	35	1-3/8
240RA	20	T11-M	801172	35	1-3/8
		T13-M	801224	42	
		T13-M	801173		1-5/8
		T17-M	801174	54	2-1/8

Type		Part No.	Connection Size		
			mm	Inch	
540RA	8	T5	046265		5/8
540RA	9	T5	046266		5/8
		T7	046268	22	7/8
540RA	12	T7	046269	22	7/8
540RA	16	T9	046270		1-1/8
540RA	20	T11	047953	35	1-1/8

200RH	3	T3	802070	10	3/8
200RH	4	T3	802071	10	
		T3	802072		3/8
		T4	802073	12	
		T4	802074		1/2
200RH	6	T4	802075	12	
		T4	802076		1/2
		T5	802077	16	

200RC	3	T3	802080	10	3/8
	4	T4	802081		1/2

Accessories and Spare Parts for Solenoid valves

Gasket Kits

consist of all O-rings and Service Tool
(except 801233)

Type	Part No.	Description
KS30040-2	801232	for 110RB
KS30039-1	801233	for 200RB/RH
KS30061-1	801234	240RA 8
KS30062-1	801235	240RA 9 /12
KS30065-1	801236	240RA 16
KS30097-1	801237	240RA 20

Type	Part No.	Description
X1198-1	027451	Service Tool for 110RB, 240RA, 540RA

Repair Kits

consist of all O-rings, enclosing tube assembly, Service Tool
(except 801205) and piston/ membrane (except 801206)

Type	Part No.	Description
KS 30040-1	801206	for 110RB
KS 30039	801205	for 200RB/RH
KS 30061	801262	240RA 8
KS 30062	801263	240RA 9
KS 30063	801264	240RA 12
KS 30065	801200	240RA 16
KS 30097	801216	240RA 20

Selection Table Accessory – ESC Coil

Coils						
Type Coils	Part No.	Supply voltage	Power Input	Description	Temperature range	Illustration
ESC-24VAC	801033 801033M*	24 VAC ±10 % 50(60) Hz	17 VA, 8 W	IP65 with plug/cable assembly acc. EN 60529 test conditions	-40...+60 °C	
ESC-230VAC	801031 801031M*	230 VAC ±10 % 50(60) Hz	17 VA, 8 W			
ESC-120VAC	801032 801032M*	120 VAC ±10 % 50(60) Hz	17 VA, 8 W			
ESC-24VDC	801030 801030M*	24 VDC	17 W			
ESC-M24VAC	801304 801304M*	24 VAC ±10 % 50(60) Hz	25 VA, 16 W			
ESC-M230VAC	801027 801027M*	24 VAC ±10 % 50(60) Hz	25 VA, 16 W			
ESC-EX24VAC	801035	24 VAC ±10 % 50 Hz	17 VA, 8 W	IP65 with molded cable assembly with 3 m length	-10...+50 °C	
ESC-EX230VAC	801036	230 VAC ±10 % 50 Hz	17 VA, 8 W			
Cable Assembly for ESC Coils						
Type	Part No.	Description	Cable length	Temperature range	Illustration	
ASC-N15	804890 804890M*	Connector Cable Assembly	1.5 m	-50...+80 °C (valid for stationary use)		
ASC-N30	804891 804891M*		3.0 m			
ASC-N60	804892 804892M*		6.0 m			
Others						
Type	Part No.	Description	Illustration			
Plug PG9	801020	Plug acc. EN 175301 with cable gland (cable Ø 4.5-7 mm)				
Plug PG11	801021	Plug acc. EN 175301 with cable gland (cable Ø 6-9 mm)				
ESC-K01	801034	Screw cap (incl. 2x O-ring & fixing retainer)				

NOTE 1: *) M = Multipack = 20 pcs.

NOTE 2: Coils are delivered with retainer kit. Please order cable assemblies separately.

NOTE 3: For more Technical Data of coils see Technical Information document of ESC.

		Nominal Capacities (kW) - Liquid													
Type	Kv (m ³ /h)	R134a	R404A R507A	R407C	R450A	R513A	R448A	R449A	R452A	R454A	R454C	R1234ze	R1234yf	R455A	
110RB	2	0.2	3.5	2.5	3.6	3.3	2.5	3.3	3.2	2.5	3.2	2.8	2.6	3.2	3
200RB	3	0.4	6.6	4.6	6.8	6.1	4.7	6.1	6.0	4.7	5.9	5.2	4.8	5.9	5.6
	4	0.9	15.5	10.9	16.1	14.5	11.0	14.5	14.2	11.0	14.0	12.4	11.4	13.9	13.1
	6	1.6	27.3	18.9	28.0	25.4	19.4	25.5	25.0	19.4	24.6	21.8	20	24.5	23.1
240RA	8	2.3	36.3	25.2	37.3	33.8	25.8	34.0	33.3	25.8	32.7	29	26.6	32.6	30.7
	9	4.8	76.2	52.9	78.4	71.0	54.2	71.3	69.8	54.2	68.7	60.9	55.9	68.5	64.5
	12	5.4	85.7	59.5	88.1	79.0	61.0	80.2	78.6	61.0	77.3	68.6	62.9	77	72.5
	16	8.8	139.1	96.5	142.9	129.5	98.9	130.1	127.4	98.9	-	-	-	124.9	-
	20	12.8	202.6	140.7	208.3	188.7	144.1	189.6	185.7	144.1	-	-	-	182	-
540RA	8	2.3	36.3	25.2	37.3	33.8	32.2	34	33.3	25.8	32.7	29	26.6	32.6	30.7
	9	4.8	76.2	52.9	78.4	71	67.7	71.3	69.8	54.2	68.7	60.9	55.9	68.5	64.5
	12	5.4	85.7	59.5	88.1	79.9	76.1	80.2	78.6	61.0	77.3	68.6	62.9	77	72.5
	16	8.8	139.1	96.5	142.9	129.5	123.5	130.1	127.4	98.9	-	-	-	124.9	-
	20	12.8	202.6	140.7	208.3	188.7	179.9	189.6	185.7	144.1	-	-	-	182	-

		Nominal Capacities (kW) - Hot Gas													
Type	Kv (m ³ /h)	R134a	R404A R507A	R407C	R450A	R513A	R448A	R449A	R452A	R454A	R454C	R1234ze	R1234yf	R455A	
110RB	2	0.2	1.6	1.7	2.1	1.4	1.5	2.0	2.0	1.7	2.0	1.8	1.3	1.3	2.0
200RB	3	0.4	3.0	3.2	3.9	2.9	3.0	4.0	4.0	3.5	4.1	3.6	2.6	2.6	3.9
	4	0.9	7.1	7.5	9.2	6.5	6.8	9.1	9.0	7.9	9.2	8.1	5.9	5.8	8.8
	6	1.6	12.5	13.1	16.1	11.6	12.1	16.2	15.9	14.0	16.4	14.3	10.5	10.4	15.7
240RA	8	2.3	16.7	17.4	21.4	16.6	17.3	23.2	22.9	20.1	23.5	20.6	15.1	14.9	22.5
	9	4.8	35.1	36.5	44.9	34.7	36.2	48.5	47.8	41.9	49.1	43.0	31.4	31.1	47.0
	12	5.4	39.4	41.1	50.5	39.0	40.7	54.5	53.8	47.2	55.2	48.4	35.4	35.0	52.8
	16	8.8	64.0	66.6	81.9	63.5	66.3	88.9	87.6	76.9	-	-	-	57.0	-
	20	12.8	93.2	97.1	119.3	92.4	96.4	129.3	127.5	111.8	-	-	-	82.9	-
540RA	8	2.3	16.7	17.4	21.4	16.6	17.3	23.2	22.9	20.1	23.5	20.6	15.1	14.9	22.5
	9	4.8	35.1	36.5	44.9	34.7	36.2	48.5	47.8	41.9	49.1	43.0	31.4	31.1	47.0
	12	5.4	39.4	41.1	50.5	39.0	40.7	54.5	53.8	47.2	55.2	48.4	35.4	35.0	52.8
	16	8.8	64.0	66.6	81.9	63.5	66.3	88.9	87.6	76.9	-	-	-	57.0	-
	20	12.8	93.2	97.1	119.3	92.4	96.4	129.3	127.5	111.8	-	-	-	82.9	-

		Nominal Capacities (kW) - Suction Gas													
Type	Kv (m ³ /h)	R134a	R404A R507A	R407C	R450A	R513A	R448A	R449A	R452A	R454A	R454C	R1234ze	R1234yf	R455A	
240RA	8	2.3	4.2	4.6	5.2	3.7	4.0	5.1	5.0	4.0	5.3	4.5	3.6	3.4	4.8
	9	4.8	8.8	9.7	10.9	7.8	8.4	10.6	10.5	8.3	11.2	9.4	7.6	7.1	9.9
	12	5.4	9.9	10.9	12.3	8.8	9.4	11.9	11.8	9.3	12.5	10.6	8.5	8.0	11.2
	16	8.8	16.0	17.7	19.9	14.3	15.3	19.4	19.2	15.2	-	-	-	13.1	-
	20	12.8	33.0	25.7	29.0	20.8	22.3	28.3	27.9	22.1	-	-	-	19.0	-
540RA	8	2.3	4.2	4.6	5.2	3.7	4.0	5.1	5.0	4.0	5.3	4.5	3.6	3.4	4.8
	9	4.8	8.8	9.7	10.9	7.8	8.4	10.6	10.5	8.3	11.2	9.4	7.6	7.1	9.9
	12	5.4	9.9	10.9	12.3	8.8	9.4	11.9	11.8	9.3	12.5	10.6	8.5	8.0	11.2
	16	8.8	16.0	17.7	19.9	14.3	15.3	19.4	19.2	15.2	-	-	-	13.1	-
	20	12.8	23.3	25.7	29.0	20.8	22.3	28.3	27.9	22.1	-	-	-	19.0	-

NOTE: Nominal Capacities at +38°C Condensing Temperature. +4°C Evaporating Temperature. 0.15 Bar Pressure Drop Between Valve inlet and Outlet in Liquid Applications (For Hot Gas Applications 1 Bar Pressure Drop and +18 °C Suction Gas Temperature); Subcooling 1 K. For selection of other operating condition, please use "Select" program (www.copeland.com/en-gb).

Type	Nominal Capacities (kW)										
	Kv (m³/h)	Liquid					Gas				
		R410A	R32	R452B	R454B	R744	R410A	R32	R452B	R454B	R744
200RH3...	0.4	6.6	9.7	7.6	7.7	8.1	4.9	5.9	5.1	5.1	7.2
200RH4...	0.9	15.7	23.0	18.0	18.2	18	11.0	13.4	11.4	11.4	16.1
200RH6...	1.6	27.5	40.3	31.7	31.9	31.7	19.5	23.8	20.3	20.3	28.7
200RC3...	0.4	-	-	-	-	8.1	-	-	-	-	7.2
200RC4...	0.9	-	-	-	-	18	-	-	-	-	16.1

NOTE: R410A/R452B/R32/R454B: Nominal capacities at +38 °C condensing temperature, +4 °C evaporating temperature, subcooling 1 K. 0.15 bar pressure drop between valve inlet and outlet in liquid applications. 1 bar pressure drop for hot gas applications.

R744: Nominal capacities at +10 °C condensing temperature, -10 °C evaporating temperature, subcooling 1 K. 0.15 bar pressure drop between valve inlet and outlet in liquid applications. 1 bar pressure drop for hot gas applications.

For selection of other operating condition, please use "Controls Navigator 4.1" or "Selection" program.

Construction

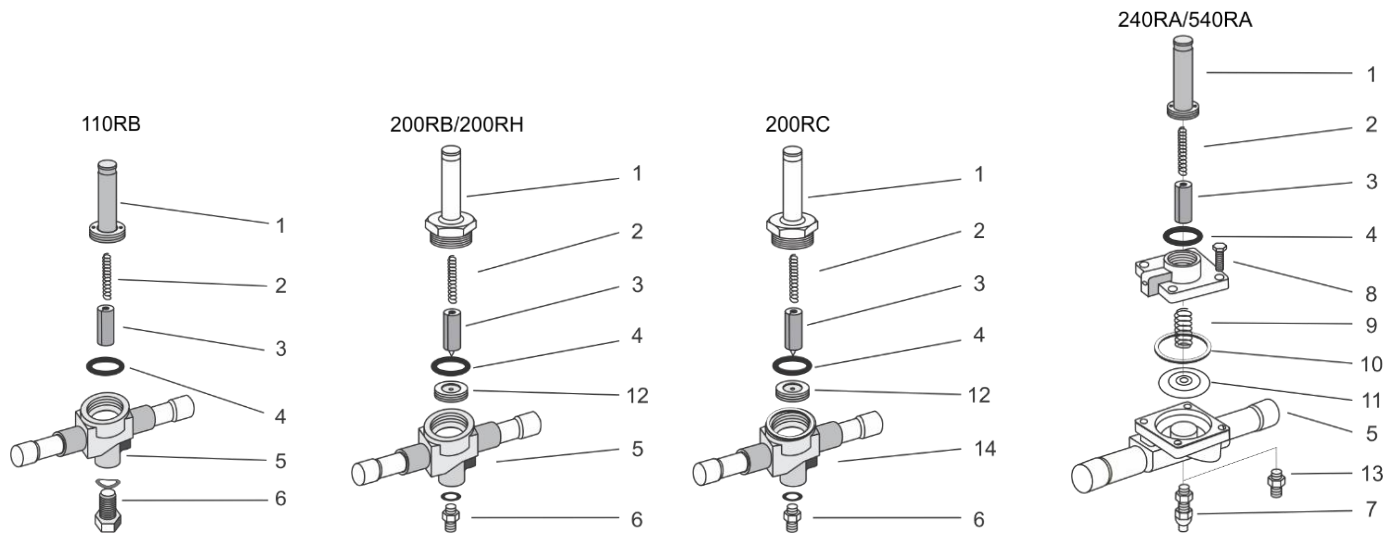

No.	Description	110RB	200RH	200RC	200RB	240RA	540RA	No.	Description	110RB	200RH	200RC	200RB	240RA	540RA
1	Enclosing Tube	X	X	X	X	X	X	8	Screw (4 pcs.)					X	X
2	Spring	X	X	X	X	X	X	9	Spring					X	X
3	Plunger	X	X	X	X	X	X	10	Gasket					X	X
4	Gasket	X	X	X	X	X	X	11	Diaphragm					X	X
5	Valve body	X	X		X	X	X	12	Piston cpl.		X	X	X		
6	Screw +washer	X	X	X	X			13	Plug					X	X
7	Manual stem					X	X	14	Valve body including ring			X			

Technical Data - Overview

Type	110RB	200RB	240RA	540RA	240RA	540RA	200RH	200RH	200RC	
Subtype	2	3/4/6	8/9/12/ 16T9	8/9/ 12/16	16T11/ 20	20	3/4/ 6T4	6T5	3/4	
Max. allowable pressure PS										
	31 bar	31 bar	31 bar	31 bar	31 bar	28 bar	60 bar	50 bar	130 bar	
Max. Test Pressure PT										
	34 bar	34 bar	34 bar	34 bar	34 bar	31 bar	66 bar	55 bar	143 bar	
Normally closed (NC) / opened (NO)										
	NC	NC	NC	NO	NC	NO	NC	NC	NC	
Material connection										
	Copper ODF									
Fluid Group										
	I +II	I +II	I +II	I +II	I	I	I+II	I+II	I	
Released Refrigerants										
A1	R134a, R404A, R407C, R450A, R452A, R448A, R449A, R507, R513A						R410A R744	R410A R744	R744 (transc.)	
A2L	R454A, R454C, R455A, R1234ze, R1234yf						R454B, R452B, R32			
Recommended coil according to Refrigerant safety class										
A1	ESC-...	ESC-...	ESC-...	ESC-...	ESC-...	ESC-...	ESC-... ESC-M...*	ESC-... ESC-M...*	ESC-... ESC-M...*	
A2L	ESC-EX...	ESC-EX...	ESC-EX...	ESC-EX...			ESC-EX...	ESC-EX...		
ΔP min (bar)										
	0	0.05	0.05	0.05	0.05	0.05	0.05	0.05	0.05	
Temperature range										
Medium	-40...+120 °C									
Ambient	-40...+50 °C									
Standards										
	EN 12284									
Markings										
CE					Cat.I / Module A					

NOTE 1: For Technical Data details ESC Coil please refer to Technical Information document for ESC.

NOTE 2: *) Temperature impacts MOPD and ESC-M coil use. Please refer to the table on page 7.

MOPD related to Fluid and Ambient temperature

Supply voltage by 21.6/ 207 VAC (24/ 230 VAC – 10 %)

		MOPD (bar)																			
		Ambient temperature (°C)																			
		-40		-30		-20		-10		0		10		20		30		40		50	
Fluid temperature (°C)	110	32		31.5		31		30.5		30		29.5									
	100	32.5		32		31.5		31		30.5		30		29.5							
	90	33		32.5		32		31.5		31		30.5		30		29.5					
	80	33.5		33		32.5		32		31.5		31		30.5		30		29.5			
	70	34	45	33.5		33		32.5		32		31.5		31		30.5		30		29.5	
	60	34.5	46.5	34	45	33.5		33		32.5		32		31.5		31		30.5		30	
	50	35	48	34.5	46.5	34	45	33.5		33		32.5		32		31.5		31		30.5	
	40	35.5	49.5	35	48	34.5	46.5	34	45	33.5		33		32.5		32		31.5		31	
	30	36	51	35.5	49.5	35	48	34.5	46.5	34	45	33.5		33		32.5		32		31.5	
	20	36.5	52.5	36	51	35.5	49.5	35	48	34.5	46.5	34	45	33.5		33		32.5		32	
	10	37	54	36.5	52.5	36	51	35.5	49.5	35	48	34.5	46.5	34	45	33.5		33		32.5	
	0	37.5	55.5	37	54	36.5	52.5	36	51	35.5	49.5	35	48	34.5	46.5	34	45	33.5		33	
	-10	38	57	37.5	55.5	37	54	36.5	52.5	36	51	35.5	49.5	35	48	34.5	46.5	34	45	33.5	
	-20	38.5	58.5	38	57	37.5	55.5	37	54	36.5	52.5	36	51	35.5	49.5	35	48	34.5	46.5	34	45
	-25	39	60	38.5	58.5	38	57	37.5	55.5	37	54	36.5	52.5	36	51	35.5	49.5	35	48	34.5	46.5

ESC-24VAC/230VAC (50 Hz)

ESC-M24VAC/M230VAC (50 Hz)

Dimension (mm)

100...

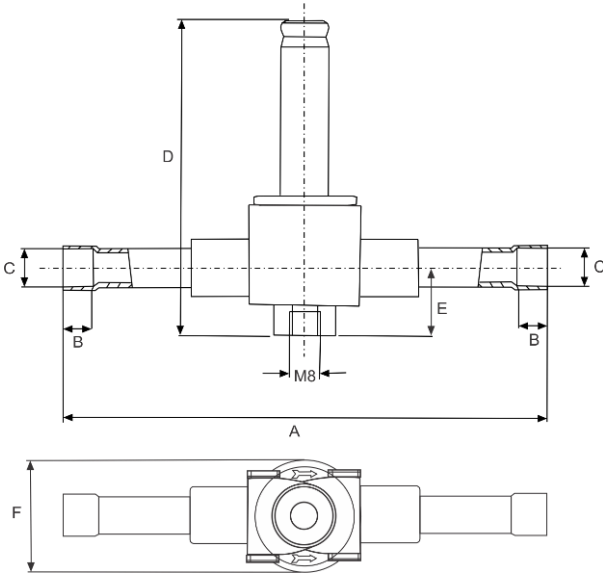

110...	Ø Port	ODF = C			mm				
		mm	mm	Inch	A	B	D	E	F
110...	3T3	3	6	1/4	126	8	77		29
110...	4T3	3	10	3/8	126	8	77		29

200...

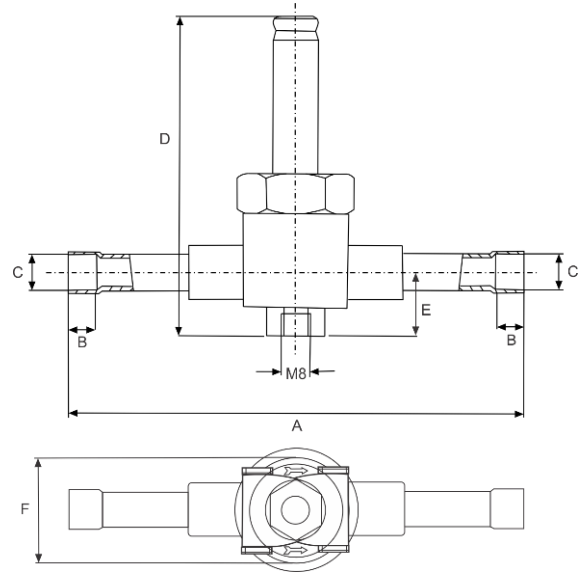

200...	Ø Port	ODF = C			mm				
		mm	mm	Inch	A	B	D	E	F
200RB/RH/RC	3T3	4.8	10	3/8	126	8	88	18	29
200 RB/RH	4T3	6	10	3/8	126	8	88	18	29
200RB/RH/RC	4T4	6	12	1/2	126	10	88	18	29
200 RB/RH	6T4	10	12	1/2	126	10	88	18	29
200 RB/RH	6T5	10	16	5/8	126	13	88	18	29

240RA/ 540RA

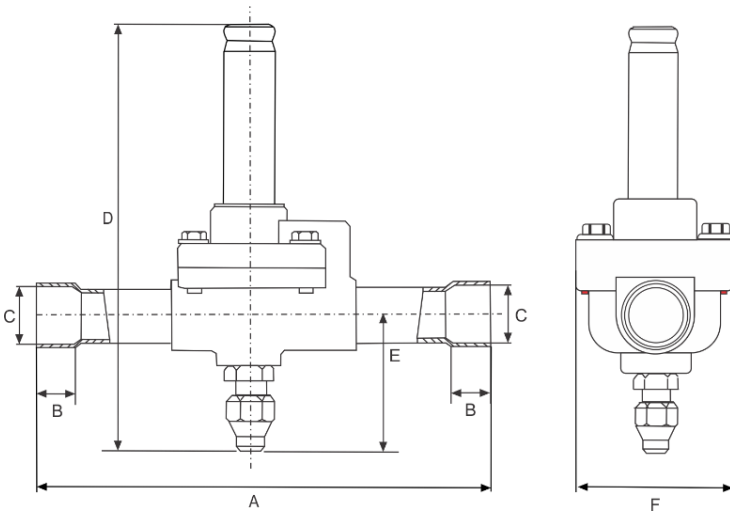

240RA	Ø Port	ODF = C			mm				
		mm	mm	Inch	A	B	D	E	F
240RA	8T5	12.5	-	5/8	175	13	100	15	57
240RA	8T7	12.5	22	7/8	181	19	100	15	57
240RA	9T5	15	16	5/8	175	13	108	20	58
240RA	9T7	15	22	7/8	181	19	108	20	58
240RA	9T9	15	-	1-1/8	216	23	108	20	58
240RA	12T7	20	22	7/8	191	19	108	20	58
240RA	12T9	20	-	1-1/8	216	23	108	20	58
240RA	16T9	25	-	1-1/8	232	23	117	23	86
240RA	16T11	25	35	1-3/8	282	24	117	23	86
240RA	20T11-M	-	35	1-3/8	276	25	164	65	103
240RA	20T13-M	32	42	1-5/8	316	28	164	65	103
240RA	20T17-M	-	54	2-1/8	351	34	164	65	103

540RA	Ø Port	ODF = C			mm				
		mm	mm	Inch	A	B	D	E	F
540RA	8T5	12.5		5/8	175	13	100	15	57
540RA	9T5	15	16	5/8	175	13	108	20	58
540RA	9T7	15	22	7/8	181	19	108	20	58
540RA	12T7	20	22	7/8	191	19	108	20	58
540RA	16T9	25		1-1/8	232	23	117	23	86
540RA	20T11		35	1-3/8	276	25	164	65	103

DISCLAIMER: The Copeland logo is a trademark and service mark of Copeland LP or one of its affiliates. Copeland Europe GmbH shall not be liable for errors in the stated capacities, dimensions, etc., as well as typographic errors. Products, specifications, assumptions, designs and technical data contained in this document are subject to modification by us without prior notice. Illustrations are not binding. ©2025 Copeland LP. All rights reserved.