



Subject:

Performance data

Application: Refrigeration & AC

Refrigerant	R449A	Compressor refrigeration capacity	55.00 kW
Reference temperature	Dew point	Evaporator refrigeration capacity	55.00 kW
Power supply	50 Hz, 400 V	Power consumption	22.60 kW
Supply frequency	50 Hz	Current draw (400 V)	44.70 A
Evaporating temperature	-10.0 °C	Coefficient of performance (COP/EER)	2.43
<i>Evaporating pressure (abs.)</i>	<i>3.58 bar</i>	Condensing capacity	77.60 kW
Condensing temperature	45.0 °C	Mass flow	0.396 kg/s
<i>Condensing pressure (abs.)</i>	<i>18.75 bar</i>	Discharge end temperature	80.6 °C ¹⁾
Suction gas superheat	8 K		
Subcooling (outside cond.)	0 K		
Usable superheat	100%		



Preliminary capacity data.

-
- 1) The stated value of the discharge end temperature is a mere calculated value. Additional cooling and heat dissipation are not considered. Deviations (particularly in deep freezing applications) from the real measured discharge temperature during operation are possible.

Subject:

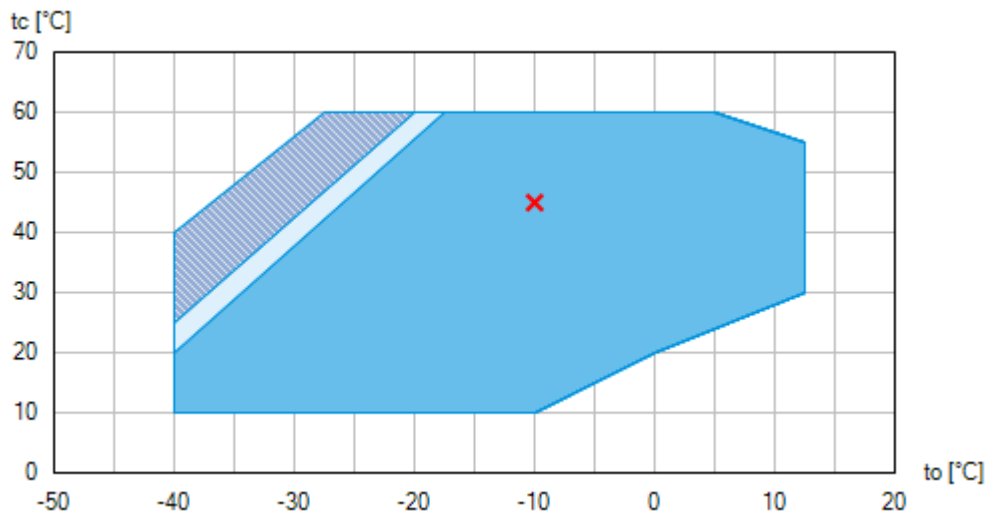
Operating limits



-  Unlimited application range
-  Supplementary cooling or reduced suction gas temperature ($\Delta t_{oh} < 20K$)
-  Supplementary cooling and reduced suction gas temperature ($\Delta t_{oh} < 20K$)

Compressor operation is possible within the limits shown on the diagrams of application. Please note the coloured areas. Compressor application limits should not be chosen for design purposes or continuous operation. Axis values refer to dew point (saturated vapour line).

BOCK® HGX66e/1340-4 S

Engine: 380-420V Y/YY -3- 50Hz PW

Refrigerant: R449A

**Subject:****Technical data**

Number of cylinders / Bore / Stroke	6 / 70 mm / 58 mm
Displacement 50/60 Hz (1450/1740 ¹ /min)	116,5 / 139,8 m ³ /h
Voltage ¹⁾	380-420V Y/YY -3- 50Hz PW
	440-480V Y/YY -3- 60Hz PW
Winding divided into	50% / 50%
Max. working current ²⁾	65.3 A
Max. power consumption ²⁾	38.1 kW
Starting current (rotor blocked) ²⁾	196.0 / 335.0 A
Motor protection	INT69 G
Protection terminal box	IP 66
Weight	287 kg
Frequency range ³⁾	25 - 60 Hz
Max. permissible overpressure (g) (LP/HP) ⁴⁾	19 / 28 bar
Connection suction line SV	54 mm - 2 1/8 "
Connection discharge line DV	42 mm - 1 5/8 "
Lubrication	Oil pump
Oil type R134a, R404A, R407A/C/F, R448A, R449A, R450A, R513A	BOCKlub E55
Oil type R22	BOCKlub A46
Oil charge	4,4 Ltr.
Oil sump heater	230 V - 1 - 50/60 Hz, 160 W
Dimensions Length / Width / Height	810 / 557 / 467 mm
Sound power level L _{WA} ⁵⁾	87 dB(A) @ -35 °C / +40 °C
	82 dB(A) @ -10 °C / +45 °C
	80 dB(A) @ +5 °C / +50 °C
Sound pressure level L _{pA} ⁵⁾	74 dB(A) @ -35 °C / +40 °C
	68 dB(A) @ -10 °C / +45 °C
	66 dB(A) @ +5 °C / +50 °C

Subject to change without notice

To:

From:

14.03.2026

Page 3 of 12

VAP 11.15.3 – vap.danfoss.com



Subject:

- 1) Tolerance ($\pm 10\%$) relates to the mean value of the voltage range. Other voltages and current types on request

All data are based on voltage rms values

PW = part winding, motors for part winding starting
(no start unloaders required)
Designs for Y/D on request
- 2) - The stated value for the max. power consumption is valid for the adjusted power supply.

- Starting current (rotor blocked):
 - Part winding (PW) motors: Winding 1 / Winding 1+2
 - Delta/Star (Δ/Y) motors: Δ / Y- Take account of the max. operating current / max. power consumption for designing motor contractors, feed lines, fuses and motor protection switches. Motor contractors: Consumption category AC3.
- 3) The maximum permissible working current of the compressor (I_{max}) must not be exceeded. Take account of the guidelines for use of frequency inverter (see compressor assembly instruction or selection software).
- 4) LP = Low pressure
HP = High pressure
- 5) Declared dual-number noise emission values are in accordance with ISO 4871. The corresponding uncertainty to the sound power level is $K_{WA} = 2,5$ dB and to the sound pressure level is $K_{pA} = 2,5$ dB. The values are valid for 50 Hz with the refrigerant R404A at the standard rating points according to EN 12900.
 - A-weighted sound power level L_{WA} (re 1 pW), in decibel. To determine the values, measurement methods of the ISO 3740 standard with accuracy class 2 or higher were used .
 - A-weighted sound pressure level L_{pA} (re 20 μ Pa), in decibel. The values are calculated from the sound power level in accordance with ISO 11203: $L_{pA} = L_{WA} - Q_2$ at a distance of $d = 1$ m to the reference box.

BOCK® HGX66e/1340-4 S

Engine: 380-420V Y/YY -3- 50Hz PW

Refrigerant: R449A



Subject:

Performance data table

Application: Refrigeration & AC

Reference temperature: Dew point

Supply frequency: 50 Hz

Voltage: 400 V

Suction gas superheat: 8 K

Subcooling (outside cond.): 0 K

tc [°C]		to [°C]									
		0.0	-5.0	-10.0	-15.0	-20.0	-25.0	-30.0	-35.0	-40.0	-45.0
10.0	Q [W]			90600	72400	57100	44500	34000	25600	18800	
	P [kW]			13.90	13.30	12.60	11.60	10.60	9.45	8.26	
	I [A]			36.10	35.70	35.10	34.40	33.60	32.90	32.10	
15.0	Q [W]		106000	85800	68500	53900	41900	31900	23800	17200	
	P [kW]		15.70	15.20	14.50	13.50	12.30	11.10	9.77	8.44	
	I [A]		37.70	37.30	36.60	35.80	34.90	34.00	33.10	32.20	
20.0	Q [W]	123000	101000	80800	64400	50600	39100	29700	21900	15500	
	P [kW]	17.80	17.30	16.60	15.60	14.30	13.00	11.50	10.00	8.56	
	I [A]	39.70	39.20	38.50	37.60	36.50	35.40	34.30	33.30	32.30	
25.0	Q [W]	116000	94100	75800	60300	47200	36400	27300	19900	13700	
	P [kW]	19.70	19.00	17.90	16.60	15.20	13.60	11.90	10.20	8.60	
	I [A]	41.60	40.80	39.80	38.60	37.20	35.90	34.60	33.40	32.30	
30.0	Q [W]	109000	88000	70700	56100	43800	33500	25000	17800	11800	
	P [kW]	21.60	20.50	19.20	17.70	15.90	14.10	12.20	10.30	8.54	
	I [A]	43.60	42.50	41.10	39.50	37.90	36.30	34.80	33.50	32.30	
35.0	Q [W]	101000	81800	65500	51800	40200	30600	22500	15800	9930	
	P [kW]	23.50	22.10	20.40	18.60	16.60	14.60	12.40	10.30	8.35	
	I [A]	45.70	44.10	42.40	40.50	38.60	36.70	35.00	33.50	32.20	
40.0	Q [W]	93500	75500	60300	47400	36600	27600	20100	13700	8050	
	P [kW]	25.20	23.50	21.60	19.50	17.20	14.90	12.50	10.20	8.02	
	I [A]	47.80	45.80	43.60	41.30	39.10	37.00	35.10	33.40	32.00	
45.0	Q [W]	86000	69200	55000	43000	33000	24600	17600	11500		
	P [kW]	26.90	24.90	22.60	20.20	17.60	15.10	12.50	9.96		
	I [A]	49.90	47.40	44.70	42.10	39.50	37.10	35.00	33.20		
50.0	Q [W]	78500	62800	49600	38600	29300	21600	15100			
	P [kW]	28.50	26.10	23.50	20.80	17.90	15.10	12.20			
	I [A]	51.90	48.90	45.80	42.70	39.80	37.10	34.80			
55.0	Q [W]	70900	56400	44200	34100	25700	18600	12600			
	P [kW]	29.90	27.20	24.20	21.20	18.00	14.90	11.80			
	I [A]	53.80	50.20	46.60	43.10	39.90	37.00	34.50			
60.0	Q [W]	63300	49900	38800	29700	22000	15600				
	P [kW]	31.20	28.10	24.80	21.40	17.90	14.50				
	I [A]	55.50	51.40	47.30	43.40	39.80	36.70				

Preliminary capacity data.



Supplementary cooling or reduced suction gas temperature ($\Delta t_{oh} < 20K$)



Supplementary cooling and reduced suction gas temperature ($\Delta t_{oh} < 20K$)

Subject to change without notice

To:

From:

14.03.2026

Page 5 of 12

VAP 11.15.3 – vap.danfoss.com

BOCK® HGX66e/1340-4 S
Engine: 380-420V Y/YY -3- 50Hz PW
Refrigerant: R449A



Subject:

t_o Evaporating temperature
t_c Condensing temperature
Q Compressor refrigeration capacity
P Power consumption
I Current draw

Subject to change without notice

To:

From:

14.03.2026
Page 6 of 12

VAP 11.15.3 – vap.danfoss.com

BOCK® HGX66e/1340-4 S

Engine: 380-420V Y/YY -3- 50Hz PW

Refrigerant: R449A



Subject:

Scope of supply

Semi-hermetic six-cylinder reciprocating compressor with drive motor for part winding start
Single-section compressor housing with hermetically integrated electric motor

Rear bearing flange prepared for oil differential pressure sensor DELTA-P II

Winding protection with PTC resistor sensors and electronic trigger unit INT69 G
115-230 V AC, 50/60 Hz, IP00

Oil pump

Possibility of connection of oil level controllers ESK, AC+R or CARLY

Possibility of connection of oil level controllers Traxoil ¹⁾

Oil charge:

HG: **BOCK**lub A46

HGX: **BOCK**lub E55

Sight glass

Internal safety valve

Suction and discharge line valve

Inert gas charge

Accessories

Capacity regulator 110 V - 1 - 50/60 Hz, IP65
1-2 capacity regulator = 66/33% residual capacity ²⁾

Capacity regulator 230 V - 1 - 50/60 Hz, IP65
1-2 capacity regulator = 66/33% residual capacity ²⁾

Cylinder cover prepared for capacity regulator ³⁾

Oil sump heater 230 V - 1 - 50/60 Hz, 160 W ³⁾

USB converter for INT69 G Diagnose ⁴⁾

Oil service valve

INT69 G Diagnose 115-230 V AC, 50/60 Hz, IP00 (INT69 G not applicable) ³⁾

Oil pressure safety switch MP54 230 V - 1 - 50/60 Hz, IP20 ⁴⁾

INT69 GTML Diagnose 115-230 V AC, 50/60 Hz, IP00, including oil differential pressure sensor INT250G,
thermal protection thermostat per cylinder covers, (INT69 G not applicable) ⁴⁾

Thermal protection thermostat per cylinder cover ³⁾

Oil differential pressure sensor DELTA-P II 220-240 V - 1 - 50/60 Hz ⁴⁾

Subject to change without notice

To:

From:

14.03.2026
Page 7 of 12

VAP 11.15.3 – vap.danfoss.com

Subject:

Connection piece suction and discharge valve in welding design

Oil temperature sensor (Pt1000, for external evaluation) ³⁾

Hot gas temperature sensor (Pt1000, for external evaluation) ³⁾

Thermal protection thermostat per cylinder cover

Additional fan

230 V AC - 1 - 50 Hz, 97 W, IP44

230 V AC - 1 - 60 Hz, 128 W ⁴⁾

Step protection ⁴⁾

Injection nozzle for liquid injection ⁴⁾

4 anti-vibration pads enclosed

Special voltage and/or frequency (on request)

-
- 1) Only with additional adapter possible
 - 2) Capacity regulator premounted, control unit enclosed
 - 3) Mounted
 - 4) Enclosure

BOCK® HGX66e/1340-4 S
Engine: 380-420V Y/YY -3- 50Hz PW
Refrigerant: R449A



Subject:

Dimensions and connections

Subject to change without notice

To:

From:

14.03.2026
Page 9 of 12

VAP 11.15.3 – vap.danfoss.com

Subject:



Maße Zubehör / Dimensions Accessories

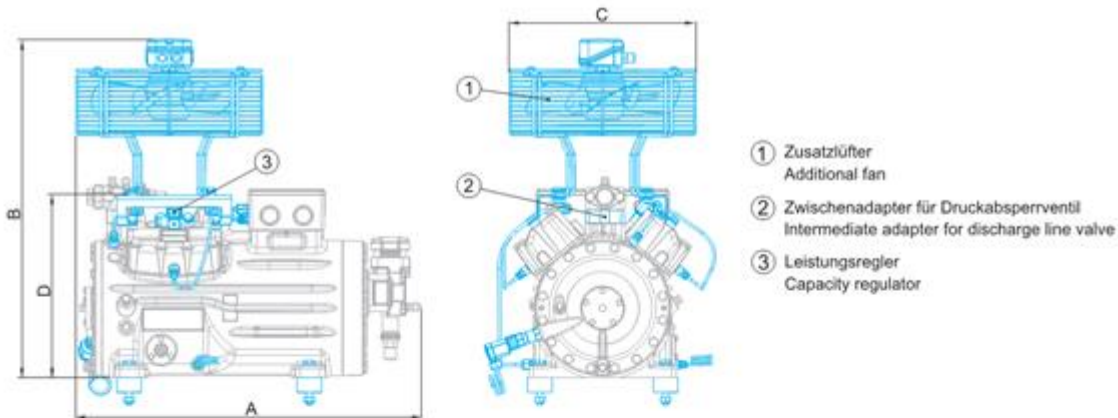

Typ / Type	A mm / inch	B mm / inch	C mm / inch	D mm / inch
HG12P	ca. 460 / 18	ca. 500 / 20	ca. 315 / 12	-
HG22e	ca. 525 / 21	ca. 610 / 24	ca. 380 / 15	-
HG34e	ca. 580 / 23	ca. 640 / 25	ca. 380 / 15	-
HG44e	ca. 710 / 28	ca. 685 / 27	ca. 380 / 15	ca. 368 / 14
HG56e	-	ca. 710 / 28	ca. 380 / 15	-
HG66e	ca. 820 / 32	ca. 800 / 31	ca. 380 / 15	-

Ansicht X: Anschlussmöglichkeit für Ölspiegelregulator
 View X: Possibility of connection of oil level regulator

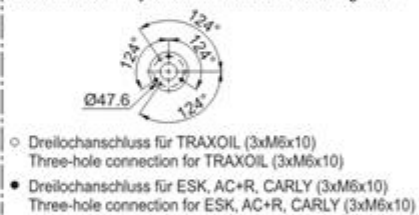

Typ / Type	Øa mm / inch	b mm / inch	c mm / inch	d mm / inch
HG12P	30 / 1.2	30 / 1.2	M8	20 / 0.8
HG22e	40 / 1.6	30 / 1.2	M10	20 / 0.8
HG34e	40 / 1.6	30 / 1.2	M10	20 / 0.8
HG44e	50 / 2.0	30 / 1.2	M12	25 / 1.0
HG56e	50 / 2.0	30 / 1.2	M12	25 / 1.0
HG66e	50 / 2.0	30 / 1.2	M12	25 / 1.0
HG88e	70 / 2.8	45 / 1.8	M12	37 / 1.5

ange without notice

BOCK® HGX66e/1340-4 S

Engine: 380-420V Y/YY -3- 50Hz PW

Refrigerant: R449A

**Subject:**

SV	Suction line valve, tube \varnothing ¹⁾	54 mm - 2 1/8 "
DV	Discharge line valve, tube \varnothing ¹⁾	42 mm - 1 5/8 "
A	Connection suction side, not lockable	1/8 " NPTF
A1	Connection suction side, lockable	7/16 " UNF
B	Connection discharge side, not lockable	1/8 " NPTF
B1	Connection discharge side, lockable	7/16 " UNF
C	Connection oil pressure safety switch OIL	1/8 " NPTF
D	Connection oil pressure safety switch LP	7/16 " UNF
D1	Connection oil return from oil separator	1/4 " NPTF
F	Oil drain	M 12 x 1.5
H	Oil charge plug	1/4 " NPTF
I	Connection hot gas temperature sensor	1/8 " NPTF
J	Connection oil sump heater	3/8 " NPTF
K	Sight glass	3 x M 6
L	Connection thermal protection thermostat	1/8 " NPTF
M	Oil strainer	M 12 x 1.5
O	Connection oil level regulator	3 x M 6
ÖV	Connection oil service valve	1/4 " NPTF
P	Connection oil differential pressure sensor	M 20 x 1.5
Q	Connection oil temperature sensor	1/8" NPTF
W	Connection for refrigerant injection	2 x 1/8" NPTF

1) Brazing connection

Subject to change without notice

To:

From:

14.03.2026
Page 11 of 12VAP 11.15.3 – vap.danfoss.com

BOCK® HGX66e/1340-4 S
Engine: 380-420V Y/YY -3- 50Hz PW
Refrigerant: R449A



Subject:

Product photo



Subject to change without notice

To:

From:

14.03.2026
Page 12 of 12

VAP 11.15.3 – vap.danfoss.com