



**Subject:**

---

**Performance data**

**Application: Refrigeration & AC**

Refrigerant	R513A	Compressor refrigeration capacity	40.60 kW
Reference temperature	Dew point	Evaporator refrigeration capacity	40.60 kW
Power supply	50 Hz, 400 V	Power consumption	16.90 kW
Supply frequency	50 Hz	Current draw (400 V)	38.80 A
Evaporating temperature	-10.0 °C	Coefficient of performance (COP/EER)	2.40
<i>Evaporating pressure (abs.)</i>	<i>2.23 bar</i>	Condensing capacity	57.60 kW
Condensing temperature	45.0 °C	Mass flow	0.347 kg/s
<i>Condensing pressure (abs.)</i>	<i>12.17 bar</i>	Discharge end temperature	66.2 °C <sup>1)</sup>
Suction gas superheat	8 K		
Subcooling (outside cond.)	0 K		
Usable superheat	100%		

*Preliminary capacity data.*

- 
- 1) The stated value of the discharge end temperature is a mere calculated value. Additional cooling and heat dissipation are not considered. Deviations (particularly in deep freezing applications) from the real measured discharge temperature during operation are possible.

**Subject:**

---

## Operating limits

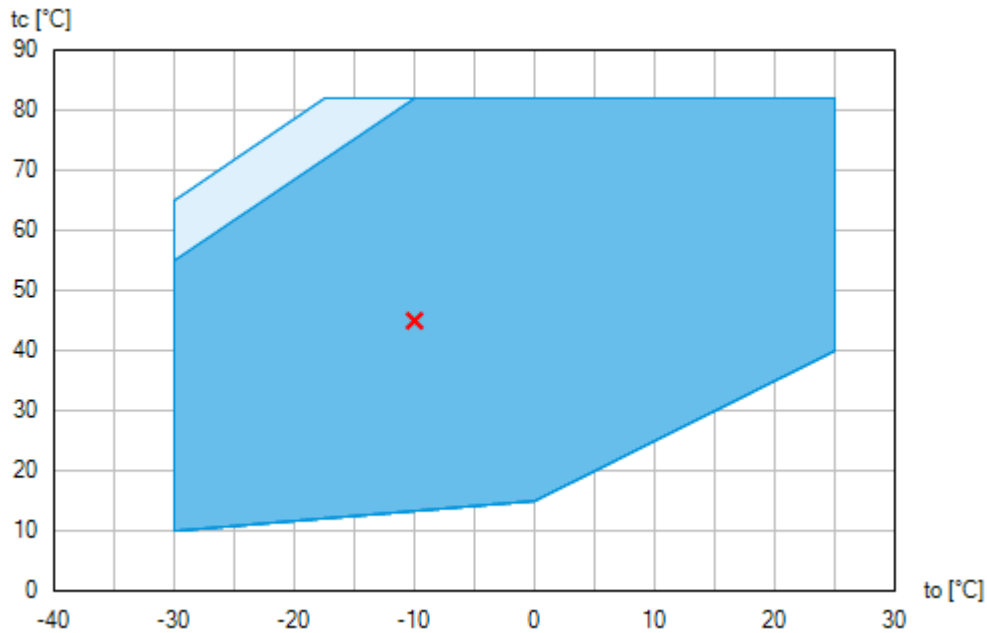

-  Unlimited application range
-  Supplementary cooling or reduced suction gas temperature ( $\Delta t_{oh} < 20K$ )

Compressor operation is possible within the limits shown on the diagrams of application. Please note the coloured areas. Compressor application limits should not be chosen for design purposes or continuous operation. Axis values refer to dew point (saturated vapour line).



**Subject:**

**Technical data**

Number of cylinders / Bore / Stroke	6 / 75 mm / 58 mm
Displacement 50/60 Hz (1450/1740 <sup>1</sup> /min)	133,8 / 160,5 m <sup>3</sup> /h
Voltage <sup>1)</sup>	380-420V Y/YY -3- 50Hz PW
	440-480V Y/YY -3- 60Hz PW
Winding divided into	50% / 50%
Max. working current <sup>2)</sup>	75.0 A
Max. power consumption <sup>2)</sup>	44.4 kW
Starting current (rotor blocked) <sup>2)</sup>	196.0 / 335.0 A
Motor protection	INT69 G
Protection terminal box	IP 66
Weight	285 kg
Frequency range <sup>3)</sup>	25 - 60 Hz
Max. permissible overpressure (g) (LP/HP) <sup>4)</sup>	19 / 28 bar
Connection suction line SV	54 mm - 2 1/8 "
Connection discharge line DV	42 mm - 1 5/8 "
Lubrication	Oil pump
Oil type R134a, R404A, R407A/C/F, R448A, R449A, R450A, R513A	BOCKlub E55
Oil type R22	BOCKlub A46
Oil charge	4,4 Ltr.
Oil sump heater	230 V - 1 - 50/60 Hz, 160 W
Dimensions Length / Width / Height	810 / 557 / 467 mm
Sound power level L <sub>WA</sub> <sup>5)</sup>	88 dB(A) @ -35 °C / +40 °C
	82 dB(A) @ -10 °C / +45 °C
	81 dB(A) @ +5 °C / +50 °C
Sound pressure level L <sub>pA</sub> <sup>5)</sup>	74 dB(A) @ -35 °C / +40 °C
	69 dB(A) @ -10 °C / +45 °C
	67 dB(A) @ +5 °C / +50 °C

Subject to change without notice

To:

From:

14.03.2026  
 Page 3 of 12



**Subject:**

---

- 1) Tolerance ( $\pm 10\%$ ) relates to the mean value of the voltage range. Other voltages and current types on request  
  
All data are based on voltage rms values  
  
PW = part winding, motors for part winding starting  
(no start unloaders required)  
Designs for Y/D on request
- 2) - The stated value for the max. power consumption is valid for the adjusted power supply.  
  
- Starting current (rotor blocked):
  - Part winding (PW) motors: Winding 1 / Winding 1+2
  - Delta/Star ( $\Delta/Y$ ) motors:  $\Delta / Y$- Take account of the max. operating current / max. power consumption for designing motor contractors, feed lines, fuses and motor protection switches. Motor contractors: Consumption category AC3.
- 3) The maximum permissible working current of the compressor ( $I_{max}$ ) must not be exceeded. Take account of the guidelines for use of frequency inverter (see compressor assembly instruction or selection software).
- 4) LP = Low pressure  
HP = High pressure
- 5) Declared dual-number noise emission values are in accordance with ISO 4871. The corresponding uncertainty to the sound power level is  $K_{WA} = 2,5$  dB and to the sound pressure level is  $K_{pA} = 2,5$  dB. The values are valid for 50 Hz with the refrigerant R404A at the standard rating points according to EN 12900.
  - A-weighted sound power level  $L_{WA}$  (re 1 pW), in decibel. To determine the values, measurement methods of the ISO 3740 standard with accuracy class 2 or higher were used .
  - A-weighted sound pressure level  $L_{pA}$  (re 20  $\mu$ Pa), in decibel. The values are calculated from the sound power level in accordance with ISO 11203:  $L_{pA} = L_{WA} - Q_2$  at a distance of  $d = 1$  m to the reference box.



**Subject:**

**Performance data table**

Application: Refrigeration & AC  
 Reference temperature: Dew point  
 Supply frequency: 50 Hz  
 Voltage: 400 V  
 Suction gas superheat: 8 K  
 Subcooling (outside cond.): 0 K

tc [°C]		to [°C]									
		10.0	5.0	0.0	-5.0	-10.0	-15.0	-20.0	-25.0	-30.0	-35.0
10.0	Q [W] P [kW] I [A]									24900 8.67 32.40	
15.0	Q [W] P [kW] I [A]			96500 12.60 35.10	78700 12.60 35.10	63400 12.20 34.80	50300 11.50 34.30	39300 10.70 33.70	30300 9.81 33.10	23000 8.87 32.50	
20.0	Q [W] P [kW] I [A]		112000 14.10 36.30	92000 14.10 36.30	74800 13.70 36.00	60000 13.10 35.50	47400 12.20 34.80	36800 11.20 34.10	28100 10.10 33.30	21100 9.05 32.60	
25.0	Q [W] P [kW] I [A]	128000 15.70 37.70	107000 15.80 37.80	87200 15.50 37.60	70600 14.90 37.00	56400 14.00 36.20	44300 12.90 35.30	34200 11.70 34.40	25900 10.40 33.50	19100 9.21 32.70	
30.0	Q [W] P [kW] I [A]	122000 17.70 39.60	101000 17.50 39.40	82000 16.90 38.80	66200 16.00 37.90	52600 14.80 36.90	41100 13.50 35.80	31500 12.10 34.70	23600 10.70 33.70	17100 9.35 32.80	
35.0	Q [W] P [kW] I [A]	114000 19.60 41.50	94100 19.10 40.90	76700 18.20 40.00	61600 17.00 38.90	48700 15.60 37.60	37800 14.00 36.30	28700 12.50 35.00	21200 10.90 33.90	15200 9.45 32.90	
40.0	Q [W] P [kW] I [A]	107000 21.40 43.40	87600 20.50 42.50	71100 19.40 41.20	56800 17.90 39.80	44700 16.30 38.20	34500 14.50 36.70	25900 12.80 35.30	19000 11.10 34.00	13400 9.51 32.90	
45.0	Q [W] P [kW] I [A]	99000 23.10 45.30	81000 21.90 44.00	65400 20.50 42.40	52000 18.80 40.60	40600 16.90 38.80	31100 15.00 37.10	23200 13.00 35.50	16800 11.20 34.10	11700 9.51 32.90	
50.0	Q [W] P [kW] I [A]	91100 24.70 47.20	74200 23.20 45.40	59600 21.50 43.50	47100 19.50 41.40	36500 17.40 39.30	27800 15.30 37.40	20500 13.20 35.60	14700 11.20 34.10	10100 9.44 32.90	
55.0	Q [W] P [kW] I [A]	83100 26.20 49.00	67300 24.40 46.80	53700 22.30 44.40	42200 20.10 42.00	32500 17.90 39.70	24500 15.50 37.60	18000 13.30 35.70	12800 11.20 34.10	8770 9.30 32.80	
60.0	Q [W] P [kW] I [A]	75000 27.50 50.60	60300 25.40 48.00	47800 23.10 45.30	37300 20.70 42.60	28500 18.20 40.00	21400 15.70 37.70	15600 13.30 35.70	11200 11.00 34.00	7710 9.08 32.60	
65.0	Q [W] P [kW] I [A]	66800 28.70 52.20	53300 26.30 49.10	41900 23.70 46.10	32400 21.10 43.00	24600 18.40 40.20	18400 15.70 37.70	13500 13.20 35.60	9700 10.80 33.80	6950 8.76 32.40	
70.0	Q [W] P [kW] I [A]	58600 29.70 53.50	46400 27.10 50.10	36100 24.20 46.60	27700 21.30 43.30	20900 18.50 40.30	15600 15.60 37.60	11600 12.90 35.40	8560 10.50 33.60		
75.0	Q [W] P [kW] I [A]	50400 30.60 54.70	39500 27.60 50.80	30400 24.60 47.00	23100 21.50 43.50	17400 18.40 40.20	13100 15.40 37.40	9890 12.60 35.10			

Subject to change without notice



**Subject:**

80.0	Q [W]	42300	32600	24900	18800	14200	10800				
	P [kW]	31.30	28.10	24.80	21.40	18.20	15.00				
	I [A]	55.60	51.40	47.30	43.40	40.00	37.10				

*Preliminary capacity data.*

Supplementary cooling or reduced suction gas temperature ( $\Delta t_{oh} < 20K$ )

- t<sub>o</sub>* Evaporating temperature
- t<sub>c</sub>* Condensing temperature
- Q* Compressor refrigeration capacity
- P* Power consumption
- I* Current draw

# BOCK® HGX66e/1540-4 S

Engine: 380-420V Y/YY -3- 50Hz PW

Refrigerant: R513A



## Subject:

---

### Scope of supply

Semi-hermetic six-cylinder reciprocating compressor with drive motor for part winding start  
Single-section compressor housing with hermetically integrated electric motor

Rear bearing flange prepared for oil differential pressure sensor DELTA-P II

Winding protection with PTC resistor sensors and electronic trigger unit INT69 G  
115-230 V AC, 50/60 Hz, IP00

Oil pump

Possibility of connection of oil level controllers ESK, AC+R or CARLY

Possibility of connection of oil level controllers Traxoil <sup>1)</sup>

Oil charge:

HG: **BOCK**lub A46

HGX: **BOCK**lub E55

Sight glass

Internal safety valve

Suction and discharge line valve

Inert gas charge

### Accessories

Capacity regulator 110 V - 1 - 50/60 Hz, IP65  
1-2 capacity regulator = 66/33% residual capacity <sup>2)</sup>

Capacity regulator 230 V - 1 - 50/60 Hz, IP65  
1-2 capacity regulator = 66/33% residual capacity <sup>2)</sup>

Cylinder cover prepared for capacity regulator <sup>3)</sup>

Oil sump heater 230 V - 1 - 50/60 Hz, 160 W <sup>3)</sup>

USB converter for INT69 G Diagnose <sup>4)</sup>

Oil service valve

INT69 G Diagnose 115-230 V AC, 50/60 Hz, IP00 (INT69 G not applicable) <sup>3)</sup>

Oil pressure safety switch MP54 230 V - 1 - 50/60 Hz, IP20 <sup>4)</sup>

INT69 GTML Diagnose 115-230 V AC, 50/60 Hz, IP00, including oil differential pressure sensor INT250G,  
thermal protection thermostat per cylinder covers, (INT69 G not applicable) <sup>4)</sup>

Thermal protection thermostat per cylinder cover <sup>3)</sup>

Oil differential pressure sensor DELTA-P II 220-240 V - 1 - 50/60 Hz <sup>4)</sup>

Subject to change without notice

---

To:

From:

14.03.2026  
Page 7 of 12

VAP 11.15.3 – [vap.danfoss.com](http://vap.danfoss.com)

# BOCK® HGX66e/1540-4 S

Engine: 380-420V Y/YY -3- 50Hz PW

Refrigerant: R513A



## Subject:

---

Connection piece suction and discharge valve in welding design

Oil temperature sensor (Pt1000, for external evaluation) <sup>3)</sup>

Hot gas temperature sensor (Pt1000, for external evaluation) <sup>3)</sup>

Thermal protection thermostat per cylinder cover

Additional fan

230 V AC - 1 - 50 Hz, 97 W, IP44

230 V AC - 1 - 60 Hz, 128 W <sup>4)</sup>

Step protection <sup>4)</sup>

Injection nozzle for liquid injection <sup>4)</sup>

4 anti-vibration pads enclosed

Special voltage and/or frequency (on request)

- 
- 1) Only with additional adapter possible
  - 2) Capacity regulator premounted, control unit enclosed
  - 3) Mounted
  - 4) Enclosure

Subject to change without notice

---

To:

From:

14.03.2026  
Page 8 of 12

VAP 11.15.3 – [vap.danfoss.com](http://vap.danfoss.com)

**BOCK® HGX66e/1540-4 S**  
Engine: 380-420V Y/YY -3- 50Hz PW  
Refrigerant: R513A



**Subject:**

---

## **Dimensions and connections**

Subject to change without notice

---

To:

From:

14.03.2026  
Page 9 of 12

VAP 11.15.3 – [vap.danfoss.com](http://vap.danfoss.com)

**Subject:**



**Maße Zubehör / Dimensions Accessories**

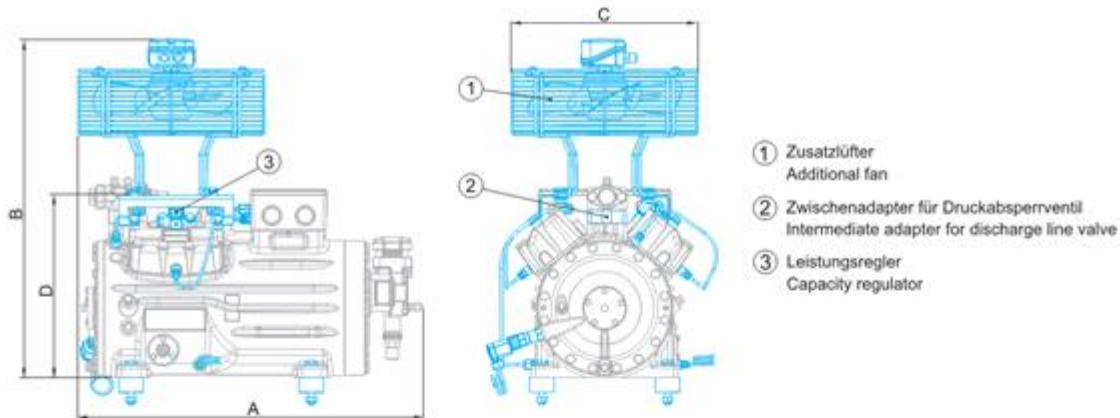

- ① Zusatzlüfter  
Additional fan
- ② Zwischenadapter für Druckabsperrentil  
Intermediate adapter for discharge line valve
- ③ Leistungsregler  
Capacity regulator

Typ / Type	A mm / inch	B mm / inch	C mm / inch	D mm / inch
HG12P	ca. 460 / 18	ca. 500 / 20	ca. 315 / 12	-
HG22e	ca. 525 / 21	ca. 610 / 24	ca. 380 / 15	-
HG34e	ca. 580 / 23	ca. 640 / 25	ca. 380 / 15	-
HG44e	ca. 710 / 28	ca. 685 / 27	ca. 380 / 15	ca. 368 / 14
HG56e	-	ca. 710 / 28	ca. 380 / 15	-
HG66e	ca. 820 / 32	ca. 800 / 31	ca. 380 / 15	-

Ansicht X: Anschlussmöglichkeit für Ölspiegelregulator  
 View X: Possibility of connection of oil level regulator

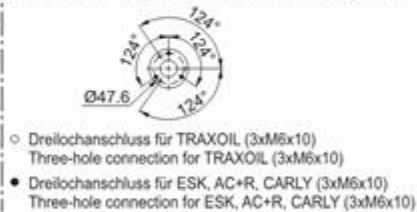

Typ / Type	Øa mm / inch	b mm / inch	c mm / inch	d mm / inch
HG12P	30 / 1.2	30 / 1.2	M8	20 / 0.8
HG22e	40 / 1.6	30 / 1.2	M10	20 / 0.8
HG34e	40 / 1.6	30 / 1.2	M10	20 / 0.8
HG44e	50 / 2.0	30 / 1.2	M12	25 / 1.0
HG56e	50 / 2.0	30 / 1.2	M12	25 / 1.0
HG66e	50 / 2.0	30 / 1.2	M12	25 / 1.0
HG88e	70 / 2.8	45 / 1.8	M12	37 / 1.5

ange without notice

**BOCK® HGX66e/1540-4 S**

Engine: 380-420V Y/YY -3- 50Hz PW

Refrigerant: R513A

**Subject:**

---

SV	Suction line valve, tube $\varnothing$ <sup>1)</sup>	54 mm - 2 1/8 "
DV	Discharge line valve, tube $\varnothing$ <sup>1)</sup>	42 mm - 1 5/8 "
A	Connection suction side, not lockable	1/8 " NPTF
A1	Connection suction side, lockable	7/16 " UNF
B	Connection discharge side, not lockable	1/8 " NPTF
B1	Connection discharge side, lockable	7/16 " UNF
C	Connection oil pressure safety switch OIL	1/8 " NPTF
D	Connection oil pressure safety switch LP	7/16 " UNF
D1	Connection oil return from oil separator	1/4 " NPTF
F	Oil drain	M 12 x 1.5
H	Oil charge plug	1/4 " NPTF
I	Connection hot gas temperature sensor	1/8 " NPTF
J	Connection oil sump heater	3/8 " NPTF
K	Sight glass	3 x M 6
L	Connection thermal protection thermostat	1/8 " NPTF
M	Oil strainer	M 12 x 1.5
O	Connection oil level regulator	3 x M 6
ÖV	Connection oil service valve	1/4 " NPTF
P	Connection oil differential pressure sensor	M 20 x 1.5
Q	Connection oil temperature sensor	1/8" NPTF
W	Connection for refrigerant injection	2 x 1/8" NPTF

---

1) Brazing connection

Subject to change without notice

---

To:

From:

14.03.2026  
Page 11 of 12VAP 11.15.3 – [vap.danfoss.com](http://vap.danfoss.com)

**BOCK® HGX66e/1540-4 S**  
Engine: 380-420V Y/YY -3- 50Hz PW  
Refrigerant: R513A



**Subject:**

---

**Product photo**



---

Subject to change without notice

To:

From:

14.03.2026  
Page 12 of 12

VAP 11.15.3 – [vap.danfoss.com](http://vap.danfoss.com)