



**Subject:**

---

**Performance data**

**Application: Refrigeration & AC**

Refrigerant	R449A	Compressor refrigeration capacity	84.90 kW
Reference temperature	Dew point	Evaporator refrigeration capacity	84.90 kW
Power supply	50 Hz, 400 V	Power consumption	35.70 kW
Supply frequency	50 Hz	Current draw (400 V)	61.90 A
Evaporating temperature	-10.0 °C	Coefficient of performance (COP/EER)	2.38
<i>Evaporating pressure (abs.)</i>	<i>3.58 bar</i>	Condensing capacity	121.00 kW
Condensing temperature	45.0 °C	Mass flow	0.612 kg/s
<i>Condensing pressure (abs.)</i>	<i>18.75 bar</i>	Discharge end temperature	81.7 °C <sup>1)</sup>
Suction gas superheat	8 K		
Subcooling (outside cond.)	0 K		
Usable superheat	100%		



*Preliminary capacity data.*

- 
- 1) The stated value of the discharge end temperature is a mere calculated value. Additional cooling and heat dissipation are not considered. Deviations (particularly in deep freezing applications) from the real measured discharge temperature during operation are possible.

**Subject:**

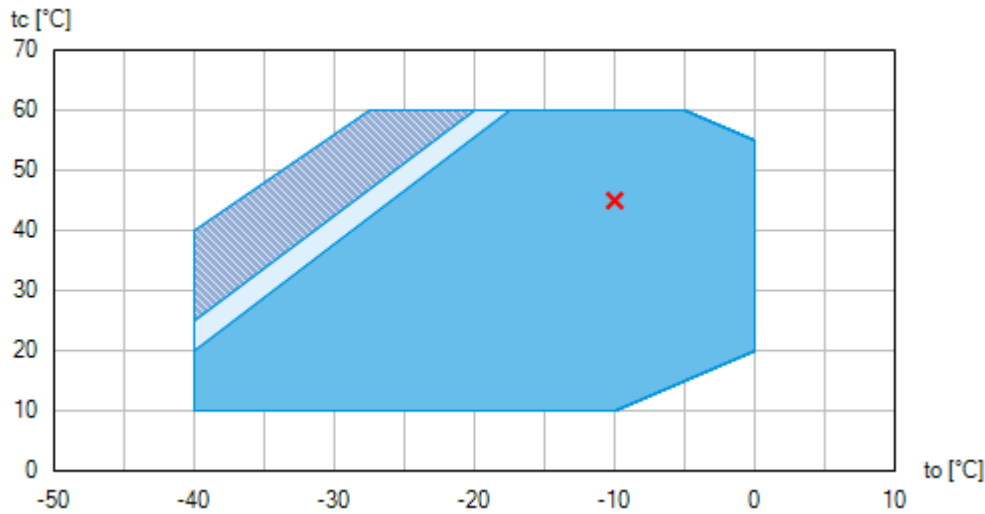
**Operating limits**



-  Unlimited application range
-  Supplementary cooling or reduced suction gas temperature ( $\Delta t_{oh} < 20K$ )
-  Supplementary cooling and reduced suction gas temperature ( $\Delta t_{oh} < 20K$ )

Compressor operation is possible within the limits shown on the diagrams of application. Please note the coloured areas. Compressor application limits should not be chosen for design purposes or continuous operation. Axis values refer to dew point (saturated vapour line).

**Subject:**

**Technical data**

Number of cylinders / Bore / Stroke	6 / 87 mm / 58 mm
Displacement 50/60 Hz (1450/1740 <sup>1</sup> /min)	180,0 / 216,0 m <sup>3</sup> /h
Voltage <sup>1)</sup>	380-420V Y/YY -3- 50Hz PW
	440-480V Y/YY -3- 60Hz PW
Winding divided into	50% / 50%
Max. working current <sup>2)</sup>	85.1 A
Max. power consumption <sup>2)</sup>	50.7 kW
Starting current (rotor blocked) <sup>2)</sup>	196.0 / 335.0 A
Motor protection	INT69 G
Protection terminal box	IP 66
Weight	276 kg
Frequency range <sup>3)</sup>	25 - 60 Hz
Max. permissible overpressure (g) (LP/HP) <sup>4)</sup>	19 / 28 bar
Connection suction line SV	64 mm - 2 5/8 "
Connection discharge line DV	42 mm - 1 5/8 "
Lubrication	Oil pump
Oil type R134a, R404A, R407A/C/F, R448A, R449A, R450A, R513A	BOCKlub E55
Oil type R22	BOCKlub A46
Oil charge	4,4 Ltr.
Oil sump heater	230 V - 1 - 50/60 Hz, 160 W
Dimensions Length / Width / Height	810 / 557 / 467 mm
Sound power level L <sub>WA</sub> <sup>5)</sup>	89 dB(A) @ -35 °C / +40 °C
	86 dB(A) @ -10 °C / +45 °C
Sound pressure level L <sub>pA</sub> <sup>5)</sup>	76 dB(A) @ -35 °C / +40 °C
	72 dB(A) @ -10 °C / +45 °C

1) Tolerance (± 10%) relates to the mean value of the voltage range. Other voltages and current types on request

All data are based on voltage rms values

PW = part winding, motors for part winding starting  
 (no start unloaders required)  
 Designs for Y/D on request

Subject to change without notice



**Subject:**

---

- 2) - The stated value for the max. power consumption is valid for the adjusted power supply.
  - Starting current (rotor blocked):
    - Part winding (PW) motors: Winding 1 / Winding 1+2
    - Delta/Star ( $\Delta/Y$ ) motors:  $\Delta / Y$
  - Take account of the max. operating current / max. power consumption for designing motor contractors, feed lines, fuses and motor protection switches. Motor contractors: Consumption category AC3.
- 3) The maximum permissible working current of the compressor ( $I_{max}$ ) must not be exceeded. Take account of the guidelines for use of frequency inverter (see compressor assembly instruction or selection software).
- 4) LP = Low pressure  
HP = High pressure
- 5) Declared dual-number noise emission values are in accordance with ISO 4871. The corresponding uncertainty to the sound power level is  $K_{WA} = 2,5$  dB and to the sound pressure level is  $K_{pA} = 2,5$  dB. The values are valid for 50 Hz with the refrigerant R404A at the standard rating points according to EN 12900.
  - A-weighted sound power level  $L_{WA}$  (re 1 pW), in decibel. To determine the values, measurement methods of the ISO 3740 standard with accuracy class 2 or higher were used .
  - A-weighted sound pressure level  $L_{pA}$  (re 20  $\mu$ Pa), in decibel. The values are calculated from the sound power level in accordance with ISO 11203:  $L_{pA} = L_{WA} - Q_2$  at a distance of  $d = 1$  m to the reference box.

---

Subject to change without notice

To:

From:

14.03.2026  
Page 4 of 12

**Subject:**

**Performance data table**

Application: Refrigeration & AC  
 Reference temperature: Dew point  
 Supply frequency: 50 Hz  
 Voltage: 400 V  
 Suction gas superheat: 8 K  
 Subcooling (outside cond.): 0 K

tc [°C]		to [°C]									
		0.0	-5.0	-10.0	-15.0	-20.0	-25.0	-30.0	-35.0	-40.0	-45.0
10.0	Q [W]			140000	112000	88300	68800	52800	39900	29500	
	P [kW]			21.30	20.50	19.30	17.90	16.20	14.40	12.50	
	I [A]			43.20	42.40	41.20	39.70	38.10	36.50	35.00	
15.0	Q [W]		164000	133000	106000	83500	64900	49700	37200	27100	
	P [kW]		24.10	23.40	22.30	20.70	18.90	17.00	14.90	12.80	
	I [A]		46.50	45.70	44.30	42.70	40.80	38.90	37.00	35.30	
20.0	Q [W]	188000	154000	125000	99500	78500	60900	46400	34400	24600	
	P [kW]	27.40	26.70	25.60	24.00	22.10	20.00	17.70	15.40	13.10	
	I [A]	50.50	49.70	48.30	46.40	44.20	41.90	39.60	37.50	35.50	
25.0	Q [W]	177000	145000	117000	93200	73300	56700	42900	31500	21900	
	P [kW]	30.50	29.40	27.80	25.80	23.50	21.00	18.40	15.80	13.30	
	I [A]	54.60	53.10	51.00	48.50	45.80	43.00	40.30	37.80	35.60	
30.0	Q [W]	166000	136000	109000	86800	68100	52400	39400	28400	19100	
	P [kW]	33.70	32.00	29.90	27.50	24.80	22.00	19.00	16.10	13.30	
	I [A]	59.00	56.60	53.80	50.60	47.30	44.00	40.90	38.10	35.70	
35.0	Q [W]	155000	126000	101000	80200	62700	48000	35700	25300	16300	
	P [kW]	36.70	34.60	32.00	29.10	26.00	22.80	19.50	16.20	13.10	
	I [A]	63.40	60.20	56.60	52.70	48.80	44.90	41.40	38.20	35.50	
40.0	Q [W]	143000	116000	93000	73600	57300	43500	32000	22100	13400	
	P [kW]	39.70	37.00	33.90	30.60	27.00	23.40	19.70	16.20	12.70	
	I [A]	67.90	63.80	59.30	54.70	50.10	45.60	41.60	38.10	35.20	
45.0	Q [W]	132000	107000	84900	66900	51800	39000	28200	18800		
	P [kW]	42.60	39.30	35.70	31.90	27.90	23.80	19.80	15.80		
	I [A]	72.30	67.30	61.90	56.50	51.10	46.10	41.60	37.80		
50.0	Q [W]	120000	96500	76800	60200	46200	34400	24300			
	P [kW]	45.30	41.50	37.30	33.00	28.50	24.00	19.50			
	I [A]	76.60	70.50	64.20	58.00	51.90	46.30	41.40			
55.0	Q [W]	109000	86700	68600	53400	40600	29800	20500			
	P [kW]	47.80	43.40	38.70	33.80	28.80	23.80	19.00			
	I [A]	80.60	73.50	66.30	59.10	52.30	46.20	40.80			
60.0	Q [W]		76900	60400	46600	35000	25200				
	P [kW]		45.00	39.70	34.30	28.80	23.40				
	I [A]		76.10	67.90	59.90	52.30	45.60				

*Preliminary capacity data.*



Supplementary cooling or reduced suction gas temperature ( $\Delta t_{oh} < 20K$ )



Supplementary cooling and reduced suction gas temperature ( $\Delta t_{oh} < 20K$ )

Subject to change without notice

To:

From:

14.03.2026  
 Page 5 of 12

**BOCK® HGX66e/2070-4**  
Engine: 380-420V Y/YY -3- 50Hz PW  
Refrigerant: R449A



**Subject:**

---

*t<sub>o</sub>* Evaporating temperature  
*t<sub>c</sub>* Condensing temperature  
*Q* Compressor refrigeration capacity  
*P* Power consumption  
*I* Current draw

Subject to change without notice

---

To:

From:

14.03.2026  
Page 6 of 12

VAP 11.15.3 – [vap.danfoss.com](http://vap.danfoss.com)

**Subject:**

---

**Scope of supply**

Semi-hermetic six-cylinder reciprocating compressor with drive motor for part winding start  
Single-section compressor housing with hermetically integrated electric motor

Rear bearing flange prepared for oil differential pressure sensor DELTA-P II

Winding protection with PTC resistor sensors and electronic trigger unit INT69 G  
115-230 V AC, 50/60 Hz, IP00

Oil pump

Possibility of connection of oil level controllers ESK, AC+R or CARLY

Possibility of connection of oil level controllers Traxoil <sup>1)</sup>

Oil charge:  
HG: **BOCK**lub A46  
HGX: **BOCK**lub E55

Sight glass

Internal safety valve

Suction and discharge line valve

Inert gas charge

**Accessories**

Capacity regulator 110 V - 1 - 50/60 Hz, IP65  
1-2 capacity regulator = 66/33% residual capacity <sup>2)</sup>

Capacity regulator 230 V - 1 - 50/60 Hz, IP65  
1-2 capacity regulator = 66/33% residual capacity <sup>2)</sup>

Cylinder cover prepared for capacity regulator <sup>3)</sup>

Oil sump heater 230 V - 1 - 50/60 Hz, 160 W <sup>3)</sup>

USB converter for INT69 G Diagnose <sup>4)</sup>

Oil service valve

INT69 G Diagnose 115-230 V AC, 50/60 Hz, IP00 (INT69 G not applicable) <sup>3)</sup>

Oil pressure safety switch MP54 230 V - 1 - 50/60 Hz, IP20 <sup>4)</sup>

INT69 GTML Diagnose 115-230 V AC, 50/60 Hz, IP00, including oil differential pressure sensor INT250G,  
thermal protection thermostat per cylinder covers, (INT69 G not applicable) <sup>4)</sup>

Thermal protection thermostat per cylinder cover <sup>3)</sup>

Oil differential pressure sensor DELTA-P II 220-240 V - 1 - 50/60 Hz <sup>4)</sup>



**Subject:**

---

Connection piece suction and discharge valve in welding design

Oil temperature sensor (Pt1000, for external evaluation) <sup>3)</sup>

Hot gas temperature sensor (Pt1000, for external evaluation) <sup>3)</sup>

Thermal protection thermostat per cylinder cover

Additional fan

230 V AC - 1 - 50 Hz, 97 W, IP44

230 V AC - 1 - 60 Hz, 128 W <sup>4)</sup>

Step protection <sup>4)</sup>

Injection nozzle for liquid injection <sup>4)</sup>

4 anti-vibration pads enclosed

Special voltage and/or frequency (on request)

- 
- 1) Only with additional adapter possible
  - 2) Capacity regulator premounted, control unit enclosed
  - 3) Mounted
  - 4) Enclosure

**BOCK® HGX66e/2070-4**  
Engine: 380-420V Y/YY -3- 50Hz PW  
Refrigerant: R449A



**Subject:**

---

## **Dimensions and connections**

Subject to change without notice

---

To:

From:

14.03.2026  
Page 9 of 12

VAP 11.15.3 – [vap.danfoss.com](http://vap.danfoss.com)

**Subject:**



**Maße Zubehör / Dimensions Accessories**

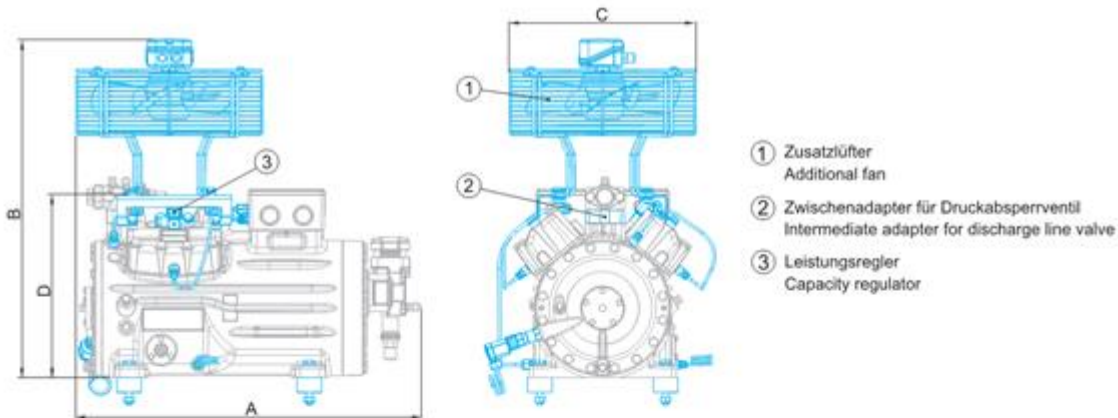

Typ / Type	A mm / inch	B mm / inch	C mm / inch	D mm / inch
HG12P	ca. 460 / 18	ca. 500 / 20	ca. 315 / 12	-
HG22e	ca. 525 / 21	ca. 610 / 24	ca. 380 / 15	-
HG34e	ca. 580 / 23	ca. 640 / 25	ca. 380 / 15	-
HG44e	ca. 710 / 28	ca. 685 / 27	ca. 380 / 15	ca. 368 / 14
HG56e	-	ca. 710 / 28	ca. 380 / 15	-
HG66e	ca. 820 / 32	ca. 800 / 31	ca. 380 / 15	-

Ansicht X: Anschlussmöglichkeit für Ölspiegelregulator  
 View X: Possibility of connection of oil level regulator

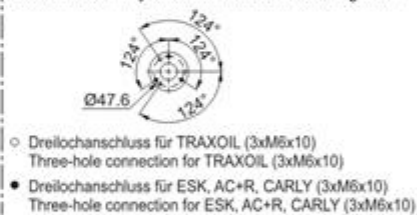

Typ / Type	Øa mm / inch	b mm / inch	c mm / inch	d mm / inch
HG12P	30 / 1.2	30 / 1.2	M8	20 / 0.8
HG22e	40 / 1.6	30 / 1.2	M10	20 / 0.8
HG34e	40 / 1.6	30 / 1.2	M10	20 / 0.8
HG44e	50 / 2.0	30 / 1.2	M12	25 / 1.0
HG56e	50 / 2.0	30 / 1.2	M12	25 / 1.0
HG66e	50 / 2.0	30 / 1.2	M12	25 / 1.0
HG88e	70 / 2.8	45 / 1.8	M12	37 / 1.5

ange without notice



**Subject:**

SV	Suction line valve, tube $\varnothing$ <sup>1)</sup>	64 mm - 2 5/8 "
DV	Discharge line valve, tube $\varnothing$ <sup>1)</sup>	42 mm - 1 5/8 "
A	Connection suction side, not lockable	1/8 " NPTF
A1	Connection suction side, lockable	7/16 " UNF
B	Connection discharge side, not lockable	1/8 " NPTF
B1	Connection discharge side, lockable	7/16 " UNF
C	Connection oil pressure safety switch OIL	1/8 " NPTF
D	Connection oil pressure safety switch LP	7/16 " UNF
D1	Connection oil return from oil separator	1/4 " NPTF
F	Oil drain	M 12 x 1.5
H	Oil charge plug	1/4 " NPTF
I	Connection hot gas temperature sensor	1/8 " NPTF
J	Connection oil sump heater	3/8 " NPTF
K	Sight glass	3 x M 6
L	Connection thermal protection thermostat	1/8 " NPTF
M	Oil strainer	M 12 x 1.5
O	Connection oil level regulator	3 x M 6
ÖV	Connection oil service valve	1/4 " NPTF
P	Connection oil differential pressure sensor	M 20 x 1.5
Q	Connection oil temperature sensor	1/8" NPTF
W	Connection for refrigerant injection	2 x 1/8" NPTF

1) Brazing connection

**BOCK® HGX66e/2070-4**  
Engine: 380-420V Y/YY -3- 50Hz PW  
Refrigerant: R449A



**Subject:**

---

**Product photo**

*Picture similar and/or with accessories.*



---

Subject to change without notice

To:

From:

14.03.2026  
Page 12 of 12

VAP 11.15.3 – [vap.danfoss.com](http://vap.danfoss.com)