



Subject:

Performance data

Application: Refrigeration & AC

| | | | |
|------------------------------------|------------------|--------------------------------------|-----------------------|
| Refrigerant | R449A | Compressor refrigeration capacity | 85.10 kW |
| Reference temperature | Dew point | Evaporator refrigeration capacity | 85.10 kW |
| Power supply | 50 Hz, 400 V | Power consumption | 35.70 kW |
| Supply frequency | 50 Hz | Current draw (400 V) | 65.70 A |
| Evaporating temperature | -10.0 °C | Coefficient of performance (COP/EER) | 2.38 |
| <i>Evaporating pressure (abs.)</i> | <i>3.58 bar</i> | Condensing capacity | 121.00 kW |
| Condensing temperature | 45.0 °C | Mass flow | 0.613 kg/s |
| <i>Condensing pressure (abs.)</i> | <i>18.75 bar</i> | Discharge end temperature | 81.6 °C ¹⁾ |
| Suction gas superheat | 8 K | | |
| Subcooling (outside cond.) | 0 K | | |
| Usable superheat | 100% | | |



Preliminary capacity data.

-
- 1) The stated value of the discharge end temperature is a mere calculated value. Additional cooling and heat dissipation are not considered. Deviations (particularly in deep freezing applications) from the real measured discharge temperature during operation are possible.

Subject:

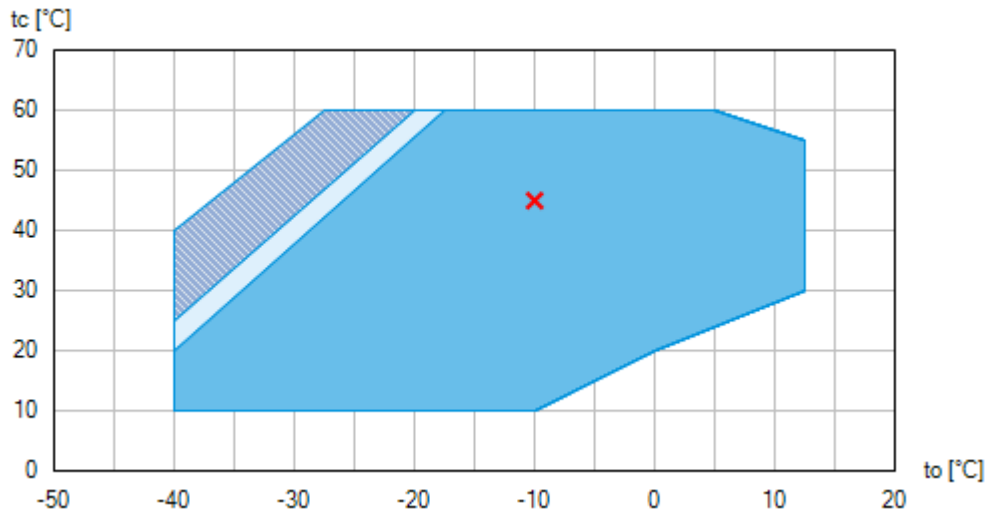
Operating limits



-  Unlimited application range
-  Supplementary cooling or reduced suction gas temperature ($\Delta t_{oh} < 20K$)
-  Supplementary cooling and reduced suction gas temperature ($\Delta t_{oh} < 20K$)

Compressor operation is possible within the limits shown on the diagrams of application. Please note the coloured areas. Compressor application limits should not be chosen for design purposes or continuous operation. Axis values refer to dew point (saturated vapour line).

Subject:

Technical data

| | |
|--|---------------------------------|
| Number of cylinders / Bore / Stroke | 6 / 87 mm / 58 mm |
| Displacement 50/60 Hz (1450/1740 ¹ /min) | 180,0 / 216,0 m ³ /h |
| Voltage ¹⁾ | 380-420V Y/YY -3- 50Hz PW |
| | 440-480V Y/YY -3- 60Hz PW |
| Winding divided into | 50% / 50% |
| Max. working current ²⁾ | 103.0 A |
| Max. power consumption ²⁾ | 60.7 kW |
| Starting current (rotor blocked) ²⁾ | 222.0 / 361.0 A |
| Motor protection | INT69 G |
| Protection terminal box | IP 66 |
| Weight | 278 kg |
| Frequency range ³⁾ | 25 - 60 Hz |
| Max. permissible overpressure (g) (LP/HP) ⁴⁾ | 19 / 28 bar |
| Connection suction line SV | 64 mm - 2 5/8 " |
| Connection discharge line DV | 42 mm - 1 5/8 " |
| Lubrication | Oil pump |
| Oil type R134a, R404A, R407A/C/F, R448A, R449A, R450A, R513A | BOCKlub E55 |
| Oil type R22 | BOCKlub A46 |
| Oil charge | 4,4 Ltr. |
| Oil sump heater | 230 V - 1 - 50/60 Hz, 160 W |
| Dimensions Length / Width / Height | 810 / 557 / 467 mm |
| Sound power level L _{WA} ⁵⁾ | 89 dB(A) @ -35 °C / +40 °C |
| | 86 dB(A) @ -10 °C / +45 °C |
| | 85 dB(A) @ +5 °C / +50 °C |
| Sound pressure level L _{pA} ⁵⁾ | 76 dB(A) @ -35 °C / +40 °C |
| | 72 dB(A) @ -10 °C / +45 °C |
| | 71 dB(A) @ +5 °C / +50 °C |

Subject to change without notice

BOCK® HGX66e/2070-4 S

Engine: 380-420V Y/YY -3- 50Hz PW

Refrigerant: R449A



Subject:

- 1) Tolerance ($\pm 10\%$) relates to the mean value of the voltage range. Other voltages and current types on request

All data are based on voltage rms values

PW = part winding, motors for part winding starting
(no start unloaders required)
Designs for Y/D on request
- 2) - The stated value for the max. power consumption is valid for the adjusted power supply.

- Starting current (rotor blocked):
 - Part winding (PW) motors: Winding 1 / Winding 1+2
 - Delta/Star (Δ/Y) motors: Δ / Y- Take account of the max. operating current / max. power consumption for designing motor contractors, feed lines, fuses and motor protection switches. Motor contractors: Consumption category AC3.
- 3) The maximum permissible working current of the compressor (I_{max}) must not be exceeded. Take account of the guidelines for use of frequency inverter (see compressor assembly instruction or selection software).
- 4) LP = Low pressure
HP = High pressure
- 5) Declared dual-number noise emission values are in accordance with ISO 4871. The corresponding uncertainty to the sound power level is $K_{WA} = 2,5$ dB and to the sound pressure level is $K_{pA} = 2,5$ dB. The values are valid for 50 Hz with the refrigerant R404A at the standard rating points according to EN 12900.
 - A-weighted sound power level L_{WA} (re 1 pW), in decibel. To determine the values, measurement methods of the ISO 3740 standard with accuracy class 2 or higher were used .
 - A-weighted sound pressure level L_{pA} (re 20 μ Pa), in decibel. The values are calculated from the sound power level in accordance with ISO 11203: $L_{pA} = L_{WA} - Q_2$ at a distance of $d = 1$ m to the reference box.

Subject to change without notice

To:

From:

14.03.2026
Page 4 of 12

VAP 11.15.3 – vap.danfoss.com



Subject:

Performance data table

Application: Refrigeration & AC
 Reference temperature: Dew point
 Supply frequency: 50 Hz
 Voltage: 400 V
 Suction gas superheat: 8 K
 Subcooling (outside cond.): 0 K

| tc [°C] | | to [°C] | | | | | | | | | |
|---------|--------|---------|--------|--------|--------|-------|-------|-------|-------|-------|-------|
| | | 0.0 | -5.0 | -10.0 | -15.0 | -20.0 | -25.0 | -30.0 | -35.0 | -40.0 | -45.0 |
| 10.0 | Q [W] | | | 140000 | 112000 | 88200 | 68800 | 52800 | 39900 | 29500 | |
| | P [kW] | | | 21.40 | 20.70 | 19.50 | 18.00 | 16.30 | 14.50 | 12.70 | |
| | I [A] | | | 49.20 | 48.50 | 47.40 | 46.00 | 44.60 | 43.10 | 41.60 | |
| 15.0 | Q [W] | | 163000 | 132000 | 106000 | 83400 | 64900 | 49700 | 37200 | 27100 | |
| | P [kW] | | 24.30 | 23.60 | 22.40 | 20.90 | 19.10 | 17.20 | 15.10 | 13.00 | |
| | I [A] | | 52.20 | 51.40 | 50.20 | 48.70 | 47.00 | 45.30 | 43.50 | 41.90 | |
| 20.0 | Q [W] | 188000 | 154000 | 125000 | 99500 | 78400 | 60900 | 46300 | 34400 | 24600 | |
| | P [kW] | 27.60 | 26.90 | 25.70 | 24.20 | 22.30 | 20.20 | 17.90 | 15.60 | 13.30 | |
| | I [A] | 55.70 | 55.00 | 53.70 | 52.10 | 50.10 | 48.00 | 45.90 | 43.90 | 42.10 | |
| 25.0 | Q [W] | 178000 | 145000 | 117000 | 93200 | 73300 | 56700 | 42900 | 31400 | 21900 | |
| | P [kW] | 30.60 | 29.50 | 27.90 | 25.90 | 23.70 | 21.20 | 18.60 | 16.00 | 13.50 | |
| | I [A] | 59.30 | 58.00 | 56.10 | 53.90 | 51.50 | 49.00 | 46.60 | 44.30 | 42.20 | |
| 30.0 | Q [W] | 166000 | 136000 | 109000 | 86800 | 68100 | 52400 | 39300 | 28400 | 19100 | |
| | P [kW] | 33.70 | 32.10 | 30.00 | 27.60 | 25.00 | 22.10 | 19.20 | 16.30 | 13.50 | |
| | I [A] | 63.10 | 61.10 | 58.60 | 55.80 | 52.90 | 49.90 | 47.10 | 44.50 | 42.20 | |
| 35.0 | Q [W] | 155000 | 126000 | 102000 | 80300 | 62700 | 48000 | 35700 | 25200 | 16300 | |
| | P [kW] | 36.70 | 34.60 | 32.10 | 29.20 | 26.10 | 22.90 | 19.70 | 16.40 | 13.30 | |
| | I [A] | 67.00 | 64.20 | 61.00 | 57.60 | 54.20 | 50.70 | 47.50 | 44.60 | 42.10 | |
| 40.0 | Q [W] | 144000 | 117000 | 93200 | 73700 | 57300 | 43500 | 31900 | 22000 | 13400 | |
| | P [kW] | 39.70 | 37.00 | 34.00 | 30.70 | 27.20 | 23.60 | 19.90 | 16.40 | 12.90 | |
| | I [A] | 70.90 | 67.30 | 63.40 | 59.30 | 55.30 | 51.40 | 47.80 | 44.60 | 41.80 | |
| 45.0 | Q [W] | 132000 | 107000 | 85100 | 67000 | 51800 | 39000 | 28100 | 18800 | | |
| | P [kW] | 42.50 | 39.30 | 35.70 | 31.90 | 28.00 | 24.00 | 19.90 | 16.00 | | |
| | I [A] | 74.80 | 70.40 | 65.70 | 60.90 | 56.20 | 51.80 | 47.80 | 44.30 | | |
| 50.0 | Q [W] | 121000 | 96800 | 77000 | 60200 | 46200 | 34400 | 24300 | | | |
| | P [kW] | 45.10 | 41.40 | 37.30 | 33.00 | 28.60 | 24.10 | 19.70 | | | |
| | I [A] | 78.60 | 73.20 | 67.70 | 62.20 | 56.90 | 52.00 | 47.60 | | | |
| 55.0 | Q [W] | 109000 | 87100 | 68800 | 53500 | 40600 | 29800 | 20500 | | | |
| | P [kW] | 47.60 | 43.20 | 38.60 | 33.80 | 28.90 | 24.00 | 19.20 | | | |
| | I [A] | 82.20 | 75.80 | 69.50 | 63.20 | 57.30 | 51.90 | 47.10 | | | |
| 60.0 | Q [W] | 97200 | 77200 | 60600 | 46700 | 35100 | 25200 | | | | |
| | P [kW] | 49.80 | 44.80 | 39.60 | 34.30 | 28.90 | 23.60 | | | | |
| | I [A] | 85.50 | 78.20 | 70.90 | 63.90 | 57.30 | 51.40 | | | | |

Preliminary capacity data.

-  Supplementary cooling or reduced suction gas temperature ($\Delta t_{oh} < 20K$)
-  Supplementary cooling and reduced suction gas temperature ($\Delta t_{oh} < 20K$)

Subject to change without notice

To:

From:

14.03.2026
 Page 5 of 12

BOCK® HGX66e/2070-4 S
Engine: 380-420V Y/YY -3- 50Hz PW
Refrigerant: R449A



Subject:

t_o Evaporating temperature
t_c Condensing temperature
Q Compressor refrigeration capacity
P Power consumption
I Current draw

Subject to change without notice

To:

From:

14.03.2026
Page 6 of 12

VAP 11.15.3 – vap.danfoss.com

Subject:

Scope of supply

Semi-hermetic six-cylinder reciprocating compressor with drive motor for part winding start
Single-section compressor housing with hermetically integrated electric motor

Rear bearing flange prepared for oil differential pressure sensor DELTA-P II

Winding protection with PTC resistor sensors and electronic trigger unit INT69 G
115-230 V AC, 50/60 Hz, IP00

Oil pump

Possibility of connection of oil level controllers ESK, AC+R or CARLY

Possibility of connection of oil level controllers Traxoil ¹⁾

Oil charge:
HG: **BOCK**lub A46
HGX: **BOCK**lub E55

Sight glass

Internal safety valve

Suction and discharge line valve

Inert gas charge

Accessories

Capacity regulator 110 V - 1 - 50/60 Hz, IP65
1-2 capacity regulator = 66/33% residual capacity ²⁾

Capacity regulator 230 V - 1 - 50/60 Hz, IP65
1-2 capacity regulator = 66/33% residual capacity ²⁾

Cylinder cover prepared for capacity regulator ³⁾

Oil sump heater 230 V - 1 - 50/60 Hz, 160 W ³⁾

USB converter for INT69 G Diagnose ⁴⁾

Oil service valve

INT69 G Diagnose 115-230 V AC, 50/60 Hz, IP00 (INT69 G not applicable) ³⁾

Oil pressure safety switch MP54 230 V - 1 - 50/60 Hz, IP20 ⁴⁾

INT69 GTML Diagnose 115-230 V AC, 50/60 Hz, IP00, including oil differential pressure sensor INT250G,
thermal protection thermostat per cylinder covers, (INT69 G not applicable) ⁴⁾

Thermal protection thermostat per cylinder cover ³⁾

Oil differential pressure sensor DELTA-P II 220-240 V - 1 - 50/60 Hz ⁴⁾

Subject to change without notice



Subject:

Connection piece suction and discharge valve in welding design

Oil temperature sensor (Pt1000, for external evaluation) ³⁾

Hot gas temperature sensor (Pt1000, for external evaluation) ³⁾

Thermal protection thermostat per cylinder cover

Additional fan

230 V AC - 1 - 50 Hz, 97 W, IP44

230 V AC - 1 - 60 Hz, 128 W ⁴⁾

Step protection ⁴⁾

Injection nozzle for liquid injection ⁴⁾

4 anti-vibration pads enclosed

Special voltage and/or frequency (on request)

-
- 1) Only with additional adapter possible
 - 2) Capacity regulator premounted, control unit enclosed
 - 3) Mounted
 - 4) Enclosure

BOCK® HGX66e/2070-4 S
Engine: 380-420V Y/YY -3- 50Hz PW
Refrigerant: R449A



Subject:

Dimensions and connections

Subject to change without notice

To:

From:

14.03.2026
Page 9 of 12

VAP 11.15.3 – vap.danfoss.com

Subject:



Maße Zubehör / Dimensions Accessories

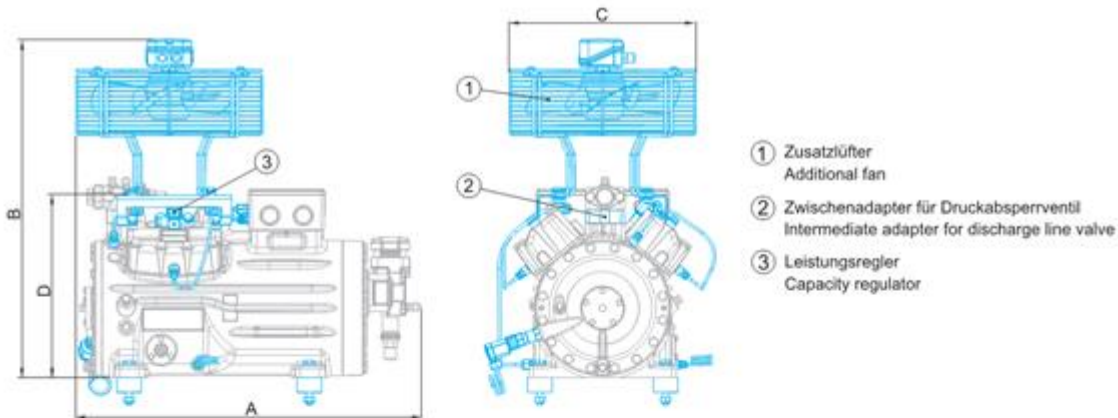

| Typ / Type | A mm / inch | B mm / inch | C mm / inch | D mm / inch |
|------------|----------------|----------------|----------------|----------------|
| HG12P | ca. 460 / 18 | ca. 500 / 20 | ca. 315 / 12 | - |
| HG22e | ca. 525 / 21 | ca. 610 / 24 | ca. 380 / 15 | - |
| HG34e | ca. 580 / 23 | ca. 640 / 25 | ca. 380 / 15 | - |
| HG44e | ca. 710 / 28 | ca. 685 / 27 | ca. 380 / 15 | ca. 368 / 14 |
| HG56e | - | ca. 710 / 28 | ca. 380 / 15 | - |
| HG66e | ca. 820 / 32 | ca. 800 / 31 | ca. 380 / 15 | - |

Ansicht X: Anschlussmöglichkeit für Ölspiegelregulator
 View X: Possibility of connection of oil level regulator

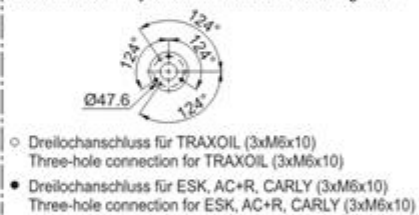

| Typ / Type | Øa mm / inch | b mm / inch | c mm / inch | d mm / inch |
|------------|-----------------|----------------|----------------|----------------|
| HG12P | 30 / 1.2 | 30 / 1.2 | M8 | 20 / 0.8 |
| HG22e | 40 / 1.6 | 30 / 1.2 | M10 | 20 / 0.8 |
| HG34e | 40 / 1.6 | 30 / 1.2 | M10 | 20 / 0.8 |
| HG44e | 50 / 2.0 | 30 / 1.2 | M12 | 25 / 1.0 |
| HG56e | 50 / 2.0 | 30 / 1.2 | M12 | 25 / 1.0 |
| HG66e | 50 / 2.0 | 30 / 1.2 | M12 | 25 / 1.0 |
| HG88e | 70 / 2.8 | 45 / 1.8 | M12 | 37 / 1.5 |

ange without notice

BOCK® HGX66e/2070-4 S

Engine: 380-420V Y/YY -3- 50Hz PW

Refrigerant: R449A

**Subject:**

| | | |
|----|--|-----------------|
| SV | Suction line valve, tube \varnothing ¹⁾ | 64 mm - 2 5/8 " |
| DV | Discharge line valve, tube \varnothing ¹⁾ | 42 mm - 1 5/8 " |
| A | Connection suction side, not lockable | 1/8 " NPTF |
| A1 | Connection suction side, lockable | 7/16 " UNF |
| B | Connection discharge side, not lockable | 1/8 " NPTF |
| B1 | Connection discharge side, lockable | 7/16 " UNF |
| C | Connection oil pressure safety switch OIL | 1/8 " NPTF |
| D | Connection oil pressure safety switch LP | 7/16 " UNF |
| D1 | Connection oil return from oil separator | 1/4 " NPTF |
| F | Oil drain | M 12 x 1.5 |
| H | Oil charge plug | 1/4 " NPTF |
| I | Connection hot gas temperature sensor | 1/8 " NPTF |
| J | Connection oil sump heater | 3/8 " NPTF |
| K | Sight glass | 3 x M 6 |
| L | Connection thermal protection thermostat | 1/8 " NPTF |
| M | Oil strainer | M 12 x 1.5 |
| O | Connection oil level regulator | 3 x M 6 |
| ÖV | Connection oil service valve | 1/4 " NPTF |
| P | Connection oil differential pressure sensor | M 20 x 1.5 |
| Q | Connection oil temperature sensor | 1/8" NPTF |
| W | Connection for refrigerant injection | 2 x 1/8" NPTF |

1) Brazing connection

Subject to change without notice

To:

From:

14.03.2026
Page 11 of 12VAP 11.15.3 – vap.danfoss.com

BOCK® HGX66e/2070-4 S
Engine: 380-420V Y/YY -3- 50Hz PW
Refrigerant: R449A



Subject:

Product photo

Picture similar and/or with accessories.



Subject to change without notice

To:

From:

14.03.2026
Page 12 of 12

VAP 11.15.3 – vap.danfoss.com