



Subject:

Performance data

Application: Refrigeration & AC

Refrigerant	R452A	Compressor refrigeration capacity	86.30 kW
Reference temperature	Dew point	Evaporator refrigeration capacity	86.30 kW
Power supply	50 Hz, 400 V	Power consumption	38.40 kW
Supply frequency	50 Hz	Current draw (400 V)	69.20 A
Evaporating temperature	-10.0 °C	Coefficient of performance (COP/EER)	2.25
<i>Evaporating pressure (abs.)</i>	<i>3.99 bar</i>	Condensing capacity	125.00 kW
Condensing temperature	45.0 °C	Mass flow	0.834 kg/s
<i>Condensing pressure (abs.)</i>	<i>19.83 bar</i>	Discharge end temperature	70.2 °C ¹⁾
Suction gas superheat	8 K		
Subcooling (outside cond.)	0 K		
Usable superheat	100%		



Preliminary capacity data.

-
- 1) The stated value of the discharge end temperature is a mere calculated value. Additional cooling and heat dissipation are not considered. Deviations (particularly in deep freezing applications) from the real measured discharge temperature during operation are possible.

Subject:

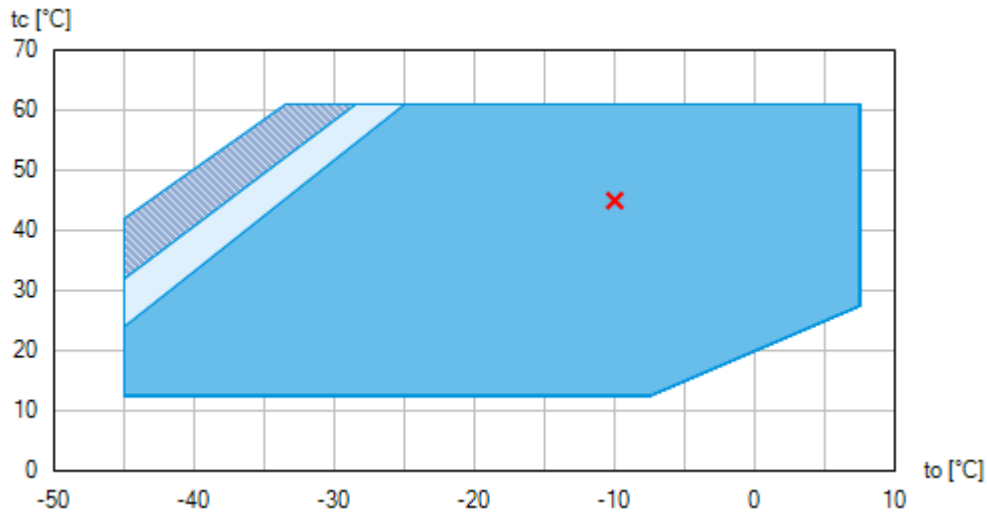
Operating limits



-  Unlimited application range
-  Supplementary cooling or reduced suction gas temperature ($\Delta t_{oh} < 20K$)
-  Supplementary cooling and reduced suction gas temperature ($\Delta t_{oh} < 20K$)

Compressor operation is possible within the limits shown on the diagrams of application. Please note the coloured areas. Compressor application limits should not be chosen for design purposes or continuous operation. Axis values refer to dew point (saturated vapour line).

Subject:

Technical data

Number of cylinders / Bore / Stroke	6 / 87 mm / 58 mm
Displacement 50/60 Hz (1450/1740 ¹ /min)	180,0 / 216,0 m ³ /h
Voltage ¹⁾	380-420V Y/YY -3- 50Hz PW
	440-480V Y/YY -3- 60Hz PW
Winding divided into	50% / 50%
Max. working current ²⁾	103.0 A
Max. power consumption ²⁾	60.7 kW
Starting current (rotor blocked) ²⁾	222.0 / 361.0 A
Motor protection	INT69 G
Protection terminal box	IP 66
Weight	278 kg
Frequency range ³⁾	25 - 60 Hz
Max. permissible overpressure (g) (LP/HP) ⁴⁾	19 / 28 bar
Connection suction line SV	64 mm - 2 5/8 "
Connection discharge line DV	42 mm - 1 5/8 "
Lubrication	Oil pump
Oil type R134a, R404A, R407A/C/F, R448A, R449A, R450A, R513A	BOCKlub E55
Oil type R22	BOCKlub A46
Oil charge	4,4 Ltr.
Oil sump heater	230 V - 1 - 50/60 Hz, 160 W
Dimensions Length / Width / Height	810 / 557 / 467 mm
Sound power level L _{WA} ⁵⁾	89 dB(A) @ -35 °C / +40 °C
	86 dB(A) @ -10 °C / +45 °C
	85 dB(A) @ +5 °C / +50 °C
Sound pressure level L _{pA} ⁵⁾	76 dB(A) @ -35 °C / +40 °C
	72 dB(A) @ -10 °C / +45 °C
	71 dB(A) @ +5 °C / +50 °C

Subject to change without notice



Subject:

- 1) Tolerance ($\pm 10\%$) relates to the mean value of the voltage range. Other voltages and current types on request

All data are based on voltage rms values

PW = part winding, motors for part winding starting
(no start unloaders required)
Designs for Y/D on request
- 2) - The stated value for the max. power consumption is valid for the adjusted power supply.

- Starting current (rotor blocked):
 - Part winding (PW) motors: Winding 1 / Winding 1+2
 - Delta/Star (Δ/Y) motors: Δ / Y- Take account of the max. operating current / max. power consumption for designing motor contractors, feed lines, fuses and motor protection switches. Motor contractors: Consumption category AC3.
- 3) The maximum permissible working current of the compressor (I_{max}) must not be exceeded. Take account of the guidelines for use of frequency inverter (see compressor assembly instruction or selection software).
- 4) LP = Low pressure
HP = High pressure
- 5) Declared dual-number noise emission values are in accordance with ISO 4871. The corresponding uncertainty to the sound power level is $K_{WA} = 2,5$ dB and to the sound pressure level is $K_{pA} = 2,5$ dB. The values are valid for 50 Hz with the refrigerant R404A at the standard rating points according to EN 12900.
 - A-weighted sound power level L_{WA} (re 1 pW), in decibel. To determine the values, measurement methods of the ISO 3740 standard with accuracy class 2 or higher were used .
 - A-weighted sound pressure level L_{pA} (re 20 μ Pa), in decibel. The values are calculated from the sound power level in accordance with ISO 11203: $L_{pA} = L_{WA} - Q_2$ at a distance of $d = 1$ m to the reference box.

BOCK® HGX66e/2070-4 S

Engine: 380-420V Y/YY -3- 50Hz PW

Refrigerant: R452A



Subject:

Performance data table

Application: Refrigeration & AC
Reference temperature: Dew point
Supply frequency: 50 Hz
Voltage: 400 V
Suction gas superheat: 8 K
Subcooling (outside cond.): 0 K

tc [°C]		to [°C]									
		0.0	-5.0	-10.0	-15.0	-20.0	-25.0	-30.0	-35.0	-40.0	-45.0
10.0	Q [W]										
	P [kW]										
	I [A]										
15.0	Q [W]		170000	140000	114000	90800	71600	55400	42000	31000	22300
	P [kW]		24.90	24.60	23.60	22.30	20.50	18.50	16.30	14.10	11.80
	I [A]		52.80	52.40	51.50	50.10	48.30	46.50	44.50	42.70	41.00
20.0	Q [W]	194000	161000	132000	107000	84700	66400	51000	38200	27700	19200
	P [kW]	28.70	28.30	27.40	25.90	24.00	21.90	19.50	17.00	14.40	12.00
	I [A]	57.00	56.60	55.50	53.90	51.90	49.70	47.40	45.10	43.00	41.10
25.0	Q [W]	182000	151000	123000	99000	78500	61200	46600	34400	24500	16400
	P [kW]	32.50	31.50	30.00	28.00	25.60	23.10	20.30	17.50	14.70	12.00
	I [A]	61.60	60.40	58.50	56.20	53.60	50.90	48.20	45.60	43.20	41.10
30.0	Q [W]	170000	140000	114000	91500	72200	55900	42200	30800	21500	13800
	P [kW]	36.10	34.50	32.40	29.90	27.10	24.10	21.00	17.90	14.90	12.00
	I [A]	66.10	64.10	61.40	58.40	55.20	52.00	48.80	45.90	43.30	41.10
35.0	Q [W]	158000	130000	105000	83900	65900	50600	37900	27300	18600	11500
	P [kW]	39.50	37.20	34.60	31.60	28.40	25.00	21.60	18.20	14.90	11.80
	I [A]	70.60	67.60	64.20	60.50	56.70	52.90	49.40	46.10	43.30	41.00
40.0	Q [W]	146000	119000	95700	76100	59400	45400	33700	24000	16000	9360
	P [kW]	42.60	39.80	36.60	33.10	29.50	25.70	22.00	18.30	14.80	11.60
	I [A]	75.00	71.10	66.80	62.40	57.90	53.70	49.80	46.30	43.30	40.80
45.0	Q [W]	133000	108000	86300	68200	52900	40100	29500	20800	13500	
	P [kW]	45.50	42.10	38.40	34.50	30.40	26.30	22.20	18.30	14.60	
	I [A]	79.20	74.30	69.20	64.10	59.00	54.30	50.00	46.20	43.10	
50.0	Q [W]	120000	96300	76700	60200	46400	34900	25400	17700	11300	
	P [kW]	48.20	44.20	40.00	35.60	31.10	26.70	22.30	18.10	14.20	
	I [A]	83.10	77.30	71.40	65.50	59.90	54.70	50.10	46.10	42.80	
55.0	Q [W]	106000	84700	67000	52100	39800	29700	21500	14700		
	P [kW]	50.60	46.10	41.40	36.50	31.70	26.80	22.20	17.80		
	I [A]	86.70	80.00	73.30	66.70	60.50	54.90	50.00	45.80		
60.0	Q [W]	91900	72900	57000	43900	33200	24600	17600			
	P [kW]	52.80	47.70	42.50	37.30	32.00	26.90	21.90			
	I [A]	90.10	82.40	74.90	67.70	61.00	54.90	49.70			

Preliminary capacity data.



Supplementary cooling or reduced suction gas temperature ($\Delta t_{oh} < 20K$)



Supplementary cooling and reduced suction gas temperature ($\Delta t_{oh} < 20K$)

Subject to change without notice

To:

From:

14.03.2026

Page 5 of 12

VAP 11.15.3 – vap.danfoss.com

BOCK® HGX66e/2070-4 S
Engine: 380-420V Y/YY -3- 50Hz PW
Refrigerant: R452A



Subject:

t_o Evaporating temperature
t_c Condensing temperature
Q Compressor refrigeration capacity
P Power consumption
I Current draw

Subject to change without notice

To:

From:

14.03.2026
Page 6 of 12

VAP 11.15.3 – vap.danfoss.com

Subject:

Scope of supply

Semi-hermetic six-cylinder reciprocating compressor with drive motor for part winding start
Single-section compressor housing with hermetically integrated electric motor

Rear bearing flange prepared for oil differential pressure sensor DELTA-P II

Winding protection with PTC resistor sensors and electronic trigger unit INT69 G
115-230 V AC, 50/60 Hz, IP00

Oil pump

Possibility of connection of oil level controllers ESK, AC+R or CARLY

Possibility of connection of oil level controllers Traxoil ¹⁾

Oil charge:
HG: **BOCK**lub A46
HGX: **BOCK**lub E55

Sight glass

Internal safety valve

Suction and discharge line valve

Inert gas charge

Accessories

Capacity regulator 110 V - 1 - 50/60 Hz, IP65
1-2 capacity regulator = 66/33% residual capacity ²⁾

Capacity regulator 230 V - 1 - 50/60 Hz, IP65
1-2 capacity regulator = 66/33% residual capacity ²⁾

Cylinder cover prepared for capacity regulator ³⁾

Oil sump heater 230 V - 1 - 50/60 Hz, 160 W ³⁾

USB converter for INT69 G Diagnose ⁴⁾

Oil service valve

INT69 G Diagnose 115-230 V AC, 50/60 Hz, IP00 (INT69 G not applicable) ³⁾

Oil pressure safety switch MP54 230 V - 1 - 50/60 Hz, IP20 ⁴⁾

INT69 GTML Diagnose 115-230 V AC, 50/60 Hz, IP00, including oil differential pressure sensor INT250G,
thermal protection thermostat per cylinder covers, (INT69 G not applicable) ⁴⁾

Thermal protection thermostat per cylinder cover ³⁾

Oil differential pressure sensor DELTA-P II 220-240 V - 1 - 50/60 Hz ⁴⁾

Subject to change without notice



Subject:

Connection piece suction and discharge valve in welding design

Oil temperature sensor (Pt1000, for external evaluation) ³⁾

Hot gas temperature sensor (Pt1000, for external evaluation) ³⁾

Thermal protection thermostat per cylinder cover

Additional fan

230 V AC - 1 - 50 Hz, 97 W, IP44

230 V AC - 1 - 60 Hz, 128 W ⁴⁾

Step protection ⁴⁾

Injection nozzle for liquid injection ⁴⁾

4 anti-vibration pads enclosed

Special voltage and/or frequency (on request)

-
- 1) Only with additional adapter possible
 - 2) Capacity regulator premounted, control unit enclosed
 - 3) Mounted
 - 4) Enclosure

BOCK® HGX66e/2070-4 S
Engine: 380-420V Y/YY -3- 50Hz PW
Refrigerant: R452A



Subject:

Dimensions and connections

Subject to change without notice

To:

From:

14.03.2026
Page 9 of 12

VAP 11.15.3 – vap.danfoss.com

Subject:



Maße Zubehör / Dimensions Accessories

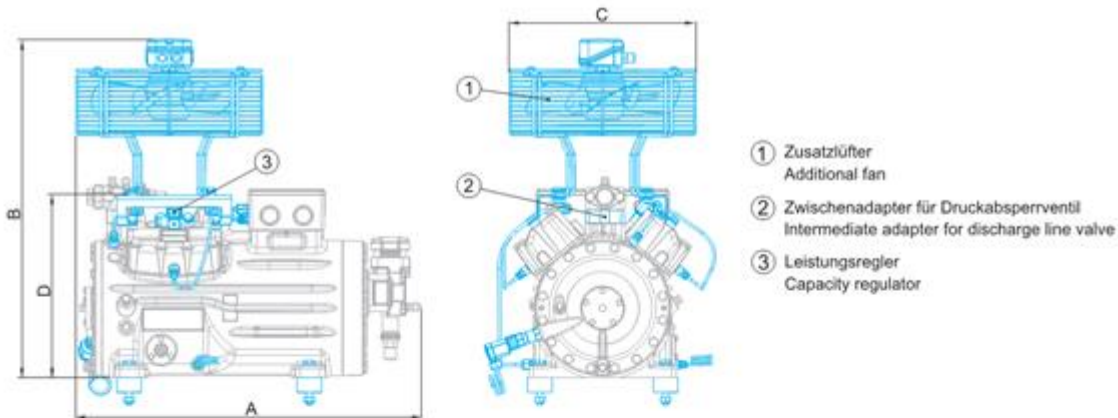

Typ / Type	A mm / inch	B mm / inch	C mm / inch	D mm / inch
HG12P	ca. 460 / 18	ca. 500 / 20	ca. 315 / 12	-
HG22e	ca. 525 / 21	ca. 610 / 24	ca. 380 / 15	-
HG34e	ca. 580 / 23	ca. 640 / 25	ca. 380 / 15	-
HG44e	ca. 710 / 28	ca. 685 / 27	ca. 380 / 15	ca. 368 / 14
HG56e	-	ca. 710 / 28	ca. 380 / 15	-
HG66e	ca. 820 / 32	ca. 800 / 31	ca. 380 / 15	-

Ansicht X: Anschlussmöglichkeit für Ölspiegelregulator
 View X: Possibility of connection of oil level regulator

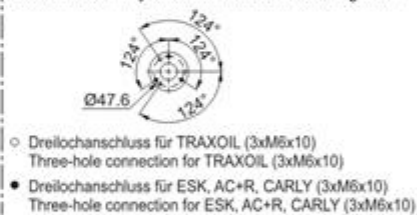

Typ / Type	Øa mm / inch	b mm / inch	c mm / inch	d mm / inch
HG12P	30 / 1.2	30 / 1.2	M8	20 / 0.8
HG22e	40 / 1.6	30 / 1.2	M10	20 / 0.8
HG34e	40 / 1.6	30 / 1.2	M10	20 / 0.8
HG44e	50 / 2.0	30 / 1.2	M12	25 / 1.0
HG56e	50 / 2.0	30 / 1.2	M12	25 / 1.0
HG66e	50 / 2.0	30 / 1.2	M12	25 / 1.0
HG88e	70 / 2.8	45 / 1.8	M12	37 / 1.5

ange without notice

BOCK® HGX66e/2070-4 S

Engine: 380-420V Y/YY -3- 50Hz PW

Refrigerant: R452A

**Subject:**

SV	Suction line valve, tube \varnothing ¹⁾	64 mm - 2 5/8 "
DV	Discharge line valve, tube \varnothing ¹⁾	42 mm - 1 5/8 "
A	Connection suction side, not lockable	1/8 " NPTF
A1	Connection suction side, lockable	7/16 " UNF
B	Connection discharge side, not lockable	1/8 " NPTF
B1	Connection discharge side, lockable	7/16 " UNF
C	Connection oil pressure safety switch OIL	1/8 " NPTF
D	Connection oil pressure safety switch LP	7/16 " UNF
D1	Connection oil return from oil separator	1/4 " NPTF
F	Oil drain	M 12 x 1.5
H	Oil charge plug	1/4 " NPTF
I	Connection hot gas temperature sensor	1/8 " NPTF
J	Connection oil sump heater	3/8 " NPTF
K	Sight glass	3 x M 6
L	Connection thermal protection thermostat	1/8 " NPTF
M	Oil strainer	M 12 x 1.5
O	Connection oil level regulator	3 x M 6
ÖV	Connection oil service valve	1/4 " NPTF
P	Connection oil differential pressure sensor	M 20 x 1.5
Q	Connection oil temperature sensor	1/8" NPTF
W	Connection for refrigerant injection	2 x 1/8" NPTF

1) Brazing connection

Subject to change without notice

To:

From:

14.03.2026
Page 11 of 12VAP 11.15.3 – vap.danfoss.com

BOCK® HGX66e/2070-4 S
Engine: 380-420V Y/YY -3- 50Hz PW
Refrigerant: R452A



Subject:

Product photo

Picture similar and/or with accessories.



Subject to change without notice

To:

From:

14.03.2026
Page 12 of 12

VAP 11.15.3 – vap.danfoss.com