



**Subject:**

---

**Performance data**

**Application: Refrigeration & AC**

Refrigerant	R452A	Compressor refrigeration capacity	102.00 kW
Reference temperature	Dew point	Evaporator refrigeration capacity	102.00 kW
Power supply	50 Hz, 400 V	Power consumption	45.40 kW
Supply frequency	50 Hz	Current draw (400 V)	80.40 A
Evaporating temperature	-10.0 °C	Coefficient of performance (COP/EER)	2.24
<i>Evaporating pressure (abs.)</i>	<i>3.99 bar</i>	Condensing capacity	148.00 kW
Condensing temperature	45.0 °C	Mass flow	0.983 kg/s
<i>Condensing pressure (abs.)</i>	<i>19.83 bar</i>	Discharge end temperature	70.4 °C <sup>1)</sup>
Suction gas superheat	8 K		
Subcooling (outside cond.)	0 K		
Usable superheat	100%		

*Preliminary capacity data.*



- 
- 1) The stated value of the discharge end temperature is a mere calculated value. Additional cooling and heat dissipation are not considered. Deviations (particularly in deep freezing applications) from the real measured discharge temperature during operation are possible.

**Subject:**

---

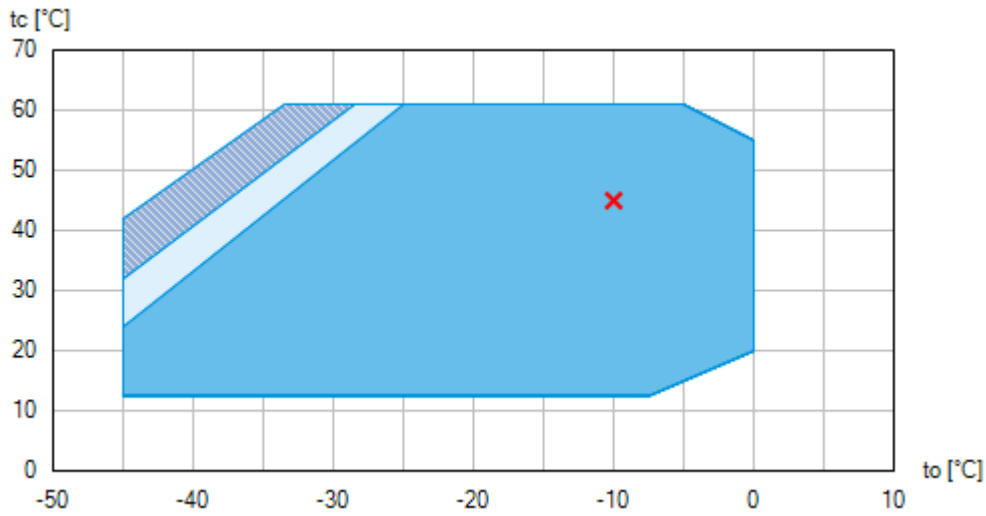
### Operating limits



-  Unlimited application range
-  Supplementary cooling or reduced suction gas temperature ( $\Delta t_{oh} < 20K$ )
-  Supplementary cooling and reduced suction gas temperature ( $\Delta t_{oh} < 20K$ )

Compressor operation is possible within the limits shown on the diagrams of application. Please note the coloured areas. Compressor application limits should not be chosen for design purposes or continuous operation. Axis values refer to dew point (saturated vapour line).

**Subject:**

**Technical data**

Number of cylinders / Bore / Stroke	8 / 75 mm / 68 mm
Displacement 50/60 Hz (1450/1740 <sup>1</sup> /min)	209,1 / 250,9 m <sup>3</sup> /h
Voltage <sup>1)</sup>	380-420V Y/YY -3- 50Hz PW
	440-480V Y/YY -3- 60Hz PW
Winding divided into	50% / 50%
Max. working current <sup>2)</sup>	101.0 A
Max. power consumption <sup>2)</sup>	59.5 kW
Starting current (rotor blocked) <sup>2)</sup>	385.0 / 543.0 A
Motor protection	INT69 G
Protection terminal box	IP 65
Weight	452 kg
Frequency range <sup>3)</sup>	25 - 60 Hz
Max. permissible overpressure (g) (LP/HP) <sup>4)</sup>	19 / 28 bar
Connection suction line SV	76 mm - 3 1/8 "
Connection discharge line DV	54 mm - 2 1/8 "
Lubrication	Oil pump
Oil type R134a, R404A, R407A/C/F, R448A, R449A, R450A, R513A	BOCKlub E55
Oil type R22	BOCKlub A46
Oil charge	9,6 Ltr.
Oil sump heater	230 V - 1 - 50/60 Hz, 200 W
Dimensions Length / Width / Height	943 / 648 / 656 mm
Sound power level L <sub>WA</sub> <sup>5)</sup>	89 dB(A) @ -35 °C / +40 °C
	86 dB(A) @ -10 °C / +45 °C
Sound pressure level L <sub>pA</sub> <sup>5)</sup>	76 dB(A) @ -35 °C / +40 °C
	72 dB(A) @ -10 °C / +45 °C

1) Tolerance (± 10%) relates to the mean value of the voltage range. Other voltages and current types on request

All data are based on voltage rms values

PW = part winding, motors for part winding starting  
 (no start unloaders required)  
 Designs for Y/D on request

Subject to change without notice



**Subject:**

---

- 2) - The stated value for the max. power consumption is valid for the adjusted power supply.
  - Starting current (rotor blocked):
    - Part winding (PW) motors: Winding 1 / Winding 1+2
    - Delta/Star ( $\Delta/Y$ ) motors:  $\Delta / Y$
  - Take account of the max. operating current / max. power consumption for designing motor contractors, feed lines, fuses and motor protection switches. Motor contractors: Consumption category AC3.
- 3) The maximum permissible working current of the compressor ( $I_{max}$ ) must not be exceeded. Take account of the guidelines for use of frequency inverter (see compressor assembly instruction or selection software).
- 4) LP = Low pressure  
HP = High pressure
- 5) Declared dual-number noise emission values are in accordance with ISO 4871. The corresponding uncertainty to the sound power level is  $K_{WA} = 2,5$  dB and to the sound pressure level is  $K_{pA} = 2,5$  dB. The values are valid for 50 Hz with the refrigerant R404A at the standard rating points according to EN 12900.
  - A-weighted sound power level  $L_{WA}$  (re 1 pW), in decibel. To determine the values, measurement methods of the ISO 3740 standard with accuracy class 2 or higher were used .
  - A-weighted sound pressure level  $L_{pA}$  (re 20  $\mu$ Pa), in decibel. The values are calculated from the sound power level in accordance with ISO 11203:  $L_{pA} = L_{WA} - Q_2$  at a distance of  $d = 1$  m to the reference box.



**Subject:**

**Performance data table**

Application: Refrigeration & AC  
 Reference temperature: Dew point  
 Supply frequency: 50 Hz  
 Voltage: 400 V  
 Suction gas superheat: 8 K  
 Subcooling (outside cond.): 0 K

tc [°C]		to [°C]										
		0.0	-5.0	-10.0	-15.0	-20.0	-25.0	-30.0	-35.0	-40.0	-45.0	
10.0	Q [W] P [kW] I [A]											
15.0	Q [W] P [kW] I [A]		200000 29.40 58.40	164000 29.00 57.90	134000 27.90 56.60	107000 26.40 54.70	84100 24.40 52.30	65100 22.10 49.80	49300 19.50 47.10	36400 16.90 44.50	26000 14.30 42.10	
20.0	Q [W] P [kW] I [A]	228000 33.80 64.10	189000 33.40 63.60	155000 32.30 62.10	125000 30.60 59.90	99600 28.50 57.20	78100 26.00 54.20	60000 23.20 51.00	44900 20.30 47.90	32600 17.40 45.00	22500 14.50 42.30	
25.0	Q [W] P [kW] I [A]	214000 38.40 70.30	177000 37.20 68.70	145000 35.40 66.20	117000 33.10 63.20	92300 30.40 59.70	71900 27.40 55.90	54800 24.20 52.20	40600 21.00 48.60	28900 17.70 45.30	19300 14.60 42.40	
30.0	Q [W] P [kW] I [A]	201000 42.60 76.30	165000 40.70 73.60	135000 38.30 70.20	108000 35.40 66.20	84900 32.10 61.90	65800 28.70 57.50	49700 25.10 53.20	36400 21.50 49.10	25400 18.00 45.50	16300 14.70 42.50	
35.0	Q [W] P [kW] I [A]	186000 46.60 82.10	153000 44.00 78.30	124000 40.90 73.90	98600 37.40 69.00	77500 33.70 63.90	59600 29.70 58.80	44700 25.80 54.00	32300 21.80 49.50	22000 18.10 45.60	13600 14.60 42.40	
40.0	Q [W] P [kW] I [A]	172000 50.30 87.50	140000 47.00 82.70	113000 43.30 77.30	89500 39.20 71.50	69900 35.00 65.70	53400 30.60 59.90	39700 26.30 54.60	28300 22.00 49.70	18900 18.00 45.60	11200 14.30 42.20	
45.0	Q [W] P [kW] I [A]	157000 53.80 92.60	127000 49.80 86.70	102000 45.40 80.40	80300 40.80 73.80	62300 36.10 67.20	47200 31.30 60.80	34800 26.60 55.00	24500 22.10 49.80	16100 17.80 45.40		
50.0	Q [W] P [kW] I [A]	142000 56.90 97.20	114000 52.30 90.40	90500 47.30 83.10	71000 42.20 75.70	54600 37.00 68.40	41100 31.80 61.50	30000 26.80 55.20	20900 22.00 49.70	13400 17.50 45.10		
55.0	Q [W] P [kW] I [A]	126000 59.80 102.00	101000 54.50 93.60	79200 49.00 85.50	61500 43.30 77.30	47000 37.70 69.30	35000 32.10 61.90	25300 26.70 55.10	17400 21.70 49.40			
60.0	Q [W] P [kW] I [A]		86600 56.40 96.50	67600 50.40 87.60	52000 44.20 78.60	39300 38.10 70.00	29000 32.20 62.00	20800 26.50 54.90				

*Preliminary capacity data.*



Supplementary cooling or reduced suction gas temperature ( $\Delta t_{oh} < 20K$ )

Supplementary cooling and reduced suction gas temperature ( $\Delta t_{oh} < 20K$ )

Subject to change without notice

To:

From:

14.03.2026  
Page 5 of 11

**BOCK® HGX88e/2400-4**  
Engine: 380-420V Y/YY -3- 50Hz PW  
Refrigerant: R452A



**Subject:**

---

*t<sub>o</sub>* Evaporating temperature  
*t<sub>c</sub>* Condensing temperature  
*Q* Compressor refrigeration capacity  
*P* Power consumption  
*I* Current draw

Subject to change without notice

---

To:

From:

14.03.2026  
Page 6 of 11

VAP 11.15.3 – [vap.danfoss.com](http://vap.danfoss.com)

**Subject:**

---

**Scope of supply**

Semi-hermetic eight-cylinder reciprocating compressor with drive motor  
Single-section Compressor housing with hermetically integrated electric motor

Winding protection with PTC resistor sensors and electronic trigger unit INT69 G  
115-230 V AC, 50/60 Hz, IP00

Oil pump

Possibility of connection of oil level controllers ESK, AC+R or CARLY

Oil pump cover with screw-in option for oil differential pressure sensor DELTA-P II

Possibility of connection of oil level controllers Traxoil <sup>1)</sup>

Oil charge:

HG: **BOCK**lub A46

HGX: **BOCK**lub E55

Three sight glasses

Pressure relief valve

Suction and discharge line valve

Inert gas charge

**Accessories**

Capacity regulator 110 V - 1 - 50/60 Hz, IP65  
1-3 capacity regulator = 75/50/25% residual capacity <sup>2)</sup>

Capacity regulator 230 V - 1 - 50/60 Hz, IP65  
1-3 capacity regulator = 75/50/25% residual capacity <sup>2)</sup>

Cylinder cover prepared for capacity regulator

Oil sump heater 230 V - 1 - 50/60 Hz, 200 W <sup>3)</sup>

Oil service valve <sup>3)</sup>

INT69 GTML Diagnose 115-230 V AC, 50/60 Hz, IP00, including oil differential pressure sensor INT250G,  
thermal protection thermostat per cylinder covers, (INT69 G not applicable)

Oil pressure safety switch MP54 230 V - 1 - 50/60 Hz, IP20 <sup>4)</sup>

Thermal protection thermostat per cylinder cover <sup>3)</sup>

Connection piece suction and discharge valve in welding design

Oil differential pressure sensor DELTA-P II 220-240 V - 1 - 50/60 Hz <sup>4)</sup>

Oil temperature sensor (Pt1000, for external evaluation) <sup>3)</sup>

Subject to change without notice



**Subject:**

---

Hot gas temperature sensor (Pt1000, for external evaluation) <sup>3)</sup>

Thermal protection thermostat per cylinder cover

USB converter for INT69 G Diagnose and INT69 GTML Diagnose <sup>4)</sup>

Additional fan  
230 V AC - 1 - 50 Hz, 97 W, IP44  
230 V AC - 1 - 60 Hz, 128 W <sup>4)</sup>

Intermediate adapter for discharge line valve <sup>4)</sup>

Step protection

4 anti-vibration pads enclosed

Special voltage and/or frequency (on request)

- 
- 1) Only with additional adapter possible
  - 2) Capacity regulator premounted, control unit enclosed
  - 3) Mounted
  - 4) Enclosure

**Subject:**

**Dimensions and connections**

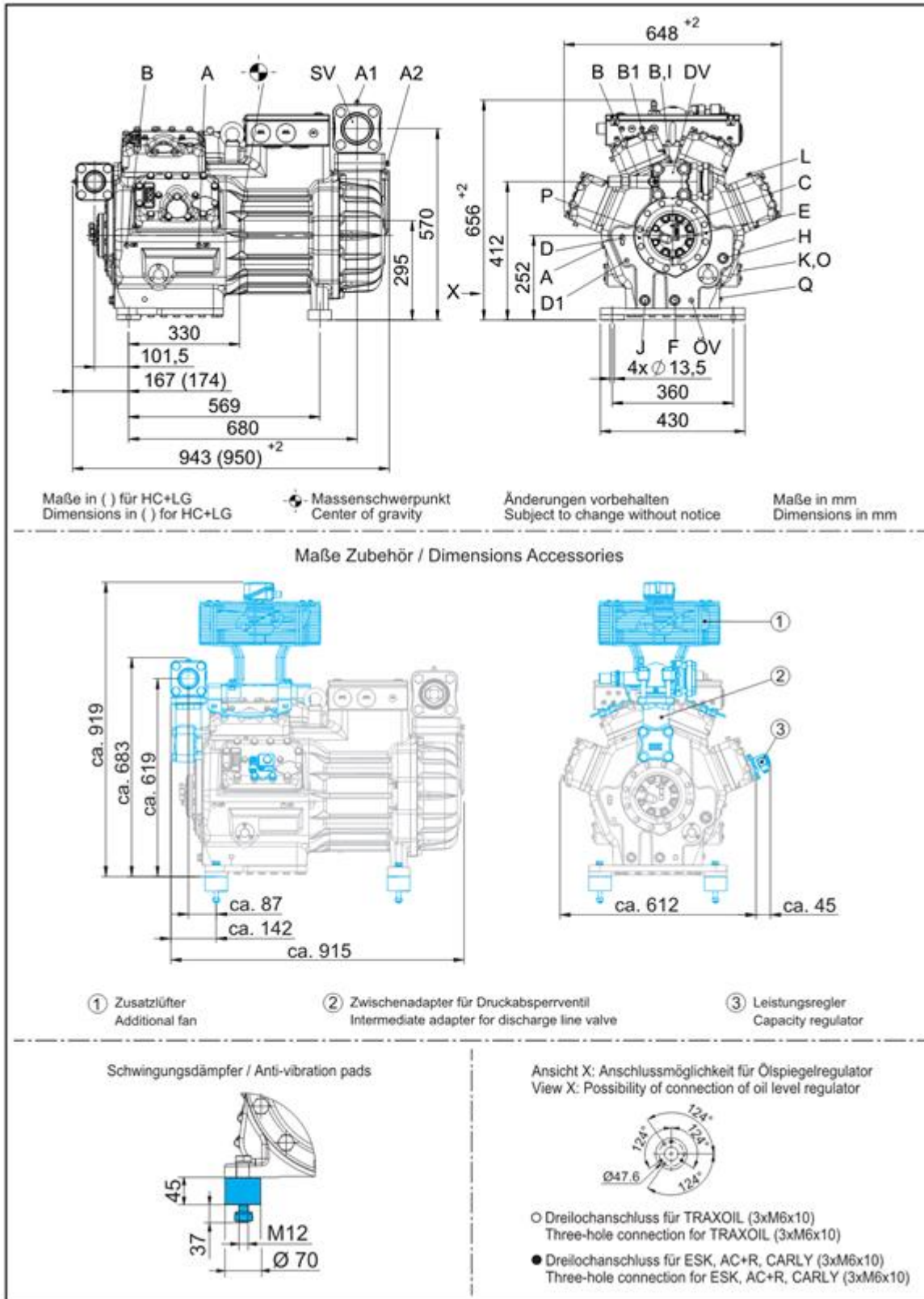

Subject to change without notice

To:

From:

14.03.2026  
 Page 9 of 11



**Subject:**

SV	Suction line valve, tube $\varnothing$ <sup>1)</sup>	76 mm - 3 1/8 "
DV	Discharge line valve, tube $\varnothing$ <sup>1)</sup>	54 mm - 2 1/8 "
A	Connection suction side, not lockable	1/8 " NPTF
A1	Connection suction side, lockable	7/16 " UNF
A2	Connection suction side, not lockable	1/4 " NPTF
B	Connection discharge side, not lockable	1/8 " NPTF
B1	Connection discharge side, lockable	7/16 " UNF
C	Connection oil pressure safety switch OIL	7/16 " UNF
D	Connection oil pressure safety switch LP	7/16 " UNF
D1	Connection oil return from oil separator	1/4 " NPTF
E	Connection oil pressure gauge	7/16 " UNF
F	Oil drain	M 22 x 1.5
H	Oil charge plug	M 22 x 1.5
I	Connection hot gas temperature sensor	1/8 " NPTF
J	Connection oil sump heater	M 22 x 1.5
K	Sight glass	3 x M 6
L	Connection thermal protection thermostat	1/8 " NPTF
O	Connection oil level regulator	3 x M 6
ÖV	Connection oil service valve	1/4 " NPTF
P	Connection oil differential pressure sensor	M 20 x 1.5
Q	Connection oil temperature sensor	1/8 " NPTF

1) Brazing connection

**BOCK® HGX88e/2400-4**  
Engine: 380-420V Y/YY -3- 50Hz PW  
Refrigerant: R452A



**Subject:**

---

**Product photo**



---

Subject to change without notice

To:

From:

14.03.2026  
Page 11 of 11

VAP 11.15.3 – [vap.danfoss.com](http://vap.danfoss.com)