



Subject:

Performance data

Application: Refrigeration & AC

Refrigerant	R452A	Compressor refrigeration capacity	103.00 kW
Reference temperature	Dew point	Evaporator refrigeration capacity	103.00 kW
Power supply	50 Hz, 400 V	Power consumption	45.40 kW
Supply frequency	50 Hz	Current draw (400 V)	84.80 A
Evaporating temperature	-10.0 °C	Coefficient of performance (COP/EER)	2.27
<i>Evaporating pressure (abs.)</i>	<i>3.99 bar</i>	Condensing capacity	149.00 kW
Condensing temperature	45.0 °C	Mass flow	0.993 kg/s
<i>Condensing pressure (abs.)</i>	<i>19.83 bar</i>	Discharge end temperature	69.9 °C ¹⁾
Suction gas superheat	8 K		
Subcooling (outside cond.)	0 K		
Usable superheat	100%		



Preliminary capacity data.

-
- 1) The stated value of the discharge end temperature is a mere calculated value. Additional cooling and heat dissipation are not considered. Deviations (particularly in deep freezing applications) from the real measured discharge temperature during operation are possible.

Subject:

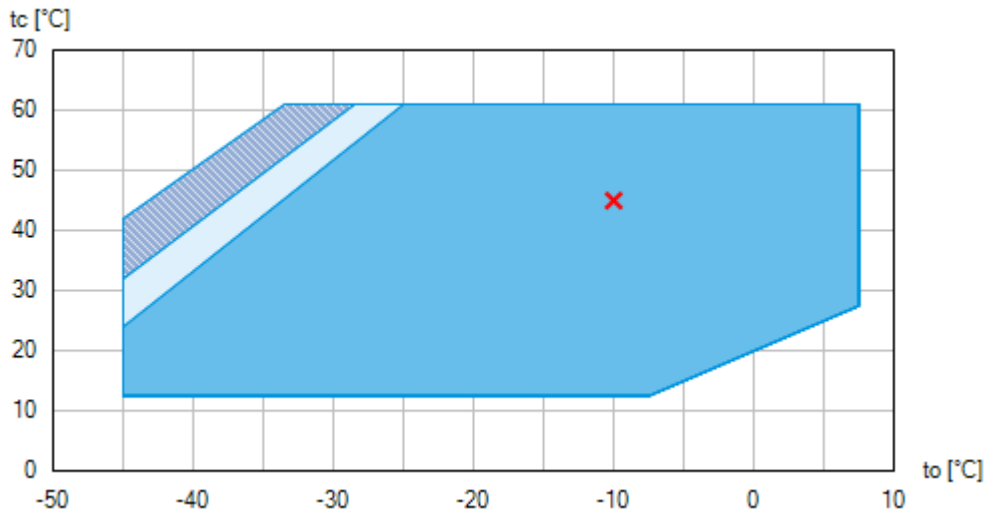
Operating limits



-  Unlimited application range
-  Supplementary cooling or reduced suction gas temperature ($\Delta t_{oh} < 20K$)
-  Supplementary cooling and reduced suction gas temperature ($\Delta t_{oh} < 20K$)

Compressor operation is possible within the limits shown on the diagrams of application. Please note the coloured areas. Compressor application limits should not be chosen for design purposes or continuous operation. Axis values refer to dew point (saturated vapour line).

Subject:

Technical data

Number of cylinders / Bore / Stroke	8 / 75 mm / 68 mm
Displacement 50/60 Hz (1450/1740 ¹ /min)	209,1 / 250,9 m ³ /h
Voltage ¹⁾	380-420V Y/YY -3- 50Hz PW
	440-480V Y/YY -3- 60Hz PW
Winding divided into	50% / 50%
Max. working current ²⁾	120.0 A
Max. power consumption ²⁾	69.8 kW
Starting current (rotor blocked) ²⁾	466.0 / 657.0 A
Motor protection	INT69 G
Protection terminal box	IP 65
Weight	452 kg
Frequency range ³⁾	25 - 60 Hz
Max. permissible overpressure (g) (LP/HP) ⁴⁾	19 / 28 bar
Connection suction line SV	76 mm - 3 1/8 "
Connection discharge line DV	54 mm - 2 1/8 "
Lubrication	Oil pump
Oil type R134a, R404A, R407A/C/F, R448A, R449A, R450A, R513A	BOCKlub E55
Oil type R22	BOCKlub A46
Oil charge	9,6 Ltr.
Oil sump heater	230 V - 1 - 50/60 Hz, 200 W
Dimensions Length / Width / Height	943 / 648 / 656 mm
Sound power level L _{WA} ⁵⁾	89 dB(A) @ -35 °C / +40 °C
	86 dB(A) @ -10 °C / +45 °C
	85 dB(A) @ +5 °C / +50 °C
Sound pressure level L _{pA} ⁵⁾	76 dB(A) @ -35 °C / +40 °C
	72 dB(A) @ -10 °C / +45 °C
	71 dB(A) @ +5 °C / +50 °C

Subject to change without notice



Subject:

- 1) Tolerance ($\pm 10\%$) relates to the mean value of the voltage range. Other voltages and current types on request

All data are based on voltage rms values

PW = part winding, motors for part winding starting
(no start unloaders required)
Designs for Y/D on request
- 2) - The stated value for the max. power consumption is valid for the adjusted power supply.

- Starting current (rotor blocked):
 - Part winding (PW) motors: Winding 1 / Winding 1+2
 - Delta/Star (Δ/Y) motors: Δ / Y- Take account of the max. operating current / max. power consumption for designing motor contractors, feed lines, fuses and motor protection switches. Motor contractors: Consumption category AC3.
- 3) The maximum permissible working current of the compressor (I_{max}) must not be exceeded. Take account of the guidelines for use of frequency inverter (see compressor assembly instruction or selection software).
- 4) LP = Low pressure
HP = High pressure
- 5) Declared dual-number noise emission values are in accordance with ISO 4871. The corresponding uncertainty to the sound power level is $K_{WA} = 2,5$ dB and to the sound pressure level is $K_{pA} = 2,5$ dB. The values are valid for 50 Hz with the refrigerant R404A at the standard rating points according to EN 12900.
 - A-weighted sound power level L_{WA} (re 1 pW), in decibel. To determine the values, measurement methods of the ISO 3740 standard with accuracy class 2 or higher were used .
 - A-weighted sound pressure level L_{pA} (re 20 μ Pa), in decibel. The values are calculated from the sound power level in accordance with ISO 11203: $L_{pA} = L_{WA} - Q_2$ at a distance of $d = 1$ m to the reference box.

Subject:

Performance data table

Application: Refrigeration & AC
 Reference temperature: Dew point
 Supply frequency: 50 Hz
 Voltage: 400 V
 Suction gas superheat: 8 K
 Subcooling (outside cond.): 0 K

tc [°C]		to [°C]										
		0.0	-5.0	-10.0	-15.0	-20.0	-25.0	-30.0	-35.0	-40.0	-45.0	
10.0	Q [W] P [kW] I [A]											
15.0	Q [W] P [kW] I [A]		202000 29.70 65.20	166000 29.30 64.70	134000 28.30 63.50	108000 26.70 61.80	84500 24.80 59.60	65400 22.50 57.20	49500 20.00 54.60	36600 17.30 52.00	26300 14.60 49.50	
20.0	Q [W] P [kW] I [A]	230000 34.00 70.30	190000 33.60 69.80	156000 32.50 68.50	126000 30.90 66.50	101000 28.80 64.10	78400 26.40 61.40	60200 23.70 58.50	45100 20.80 55.40	32700 17.80 52.50	22600 14.80 49.70	
25.0	Q [W] P [kW] I [A]	216000 38.30 75.70	179000 37.20 74.20	146000 35.50 72.10	118000 33.30 69.40	92900 30.70 66.40	72300 27.80 63.00	55000 24.70 59.60	40700 21.40 56.10	28900 18.20 52.80	19300 14.90 49.70	
30.0	Q [W] P [kW] I [A]	203000 42.40 80.90	167000 40.60 78.60	136000 38.30 75.60	109000 35.50 72.20	85500 32.40 68.40	66200 29.10 64.50	49900 25.60 60.50	36400 22.00 56.70	25400 18.40 53.00	16300 14.90 49.70	
35.0	Q [W] P [kW] I [A]	188000 46.20 86.00	155000 43.80 82.80	125000 40.90 78.90	99500 37.60 74.70	78100 34.00 70.30	60000 30.20 65.70	44900 26.30 61.30	32300 22.30 57.00	22000 18.50 53.10	13600 14.70 49.60	
40.0	Q [W] P [kW] I [A]	174000 49.80 90.90	142000 46.70 86.70	114000 43.20 82.00	90400 39.40 77.00	70500 35.30 71.90	53800 31.10 66.80	39900 26.80 61.90	28400 22.50 57.30	18900 18.40 53.10	11200 14.50 49.30	
45.0	Q [W] P [kW] I [A]	159000 53.10 95.60	129000 49.40 90.40	103000 45.40 84.80	81100 41.00 79.10	62800 36.50 73.30	47600 31.80 67.60	35000 27.20 62.30	24600 22.60 57.30	16100 18.20 52.80		
50.0	Q [W] P [kW] I [A]	143000 56.20 99.90	115000 51.90 93.80	91400 47.20 87.40	71600 42.40 80.90	55100 37.40 74.50	41400 32.30 68.30	30200 27.30 62.50	21000 22.50 57.20	13500 17.80 52.50		
55.0	Q [W] P [kW] I [A]	127000 59.00 104.00	102000 54.10 96.90	79800 48.90 89.70	62000 43.50 82.40	47300 38.10 75.40	35300 32.70 68.60	25500 27.30 62.40	17600 22.20 56.90			
60.0	Q [W] P [kW] I [A]	111000 61.50 108.00	87200 56.00 99.60	68000 50.30 91.60	52300 44.50 83.60	39500 38.60 76.00	29200 32.80 68.80	20900 27.10 62.20				

Preliminary capacity data.



Supplementary cooling or reduced suction gas temperature ($\Delta t_{oh} < 20K$)



Supplementary cooling and reduced suction gas temperature ($\Delta t_{oh} < 20K$)

Subject to change without notice

To:

From:

14.03.2026
Page 5 of 11

BOCK® HGX88e/2400-4 S
Engine: 380-420V Y/YY -3- 50Hz PW
Refrigerant: R452A



Subject:

t_o Evaporating temperature
t_c Condensing temperature
Q Compressor refrigeration capacity
P Power consumption
I Current draw

Subject to change without notice

To:

From:

14.03.2026
Page 6 of 11

VAP 11.15.3 – vap.danfoss.com

BOCK® HGX88e/2400-4 S

Engine: 380-420V Y/YY -3- 50Hz PW

Refrigerant: R452A



Subject:

Scope of supply

Semi-hermetic eight-cylinder reciprocating compressor with drive motor
Single-section Compressor housing with hermetically integrated electric motor

Winding protection with PTC resistor sensors and electronic trigger unit INT69 G
115-230 V AC, 50/60 Hz, IP00

Oil pump

Possibility of connection of oil level controllers ESK, AC+R or CARLY

Oil pump cover with screw-in option for oil differential pressure sensor DELTA-P II

Possibility of connection of oil level controllers Traxoil ¹⁾

Possibility for connection of oil pressure safety switch MP54

Oil charge:

HG: **BOCK**lub A46

HGX: **BOCK**lub E55

Three sight glasses

Pressure relief valve

Suction and discharge line valve

Inert gas charge

Accessories

Capacity regulator 110 V - 1 - 50/60 Hz, IP65
1-3 capacity regulator = 75/50/25% residual capacity ²⁾

Capacity regulator 230 V - 1 - 50/60 Hz, IP65
1-3 capacity regulator = 75/50/25% residual capacity ²⁾

Cylinder cover prepared for capacity regulator

Oil sump heater 230 V - 1 - 50/60 Hz, 200 W ³⁾

Oil service valve ³⁾

INT69 GTML Diagnose 115-230 V AC, 50/60 Hz, IP00, including oil differential pressure sensor INT250G, thermal protection thermostat per cylinder covers, (INT69 G not applicable)

Oil pressure safety switch MP54 230 V - 1 - 50/60 Hz, IP20 ⁴⁾

Thermal protection thermostat per cylinder cover ³⁾

Connection piece suction and discharge valve in welding design

Oil differential pressure sensor DELTA-P II 220-240 V - 1 - 50/60 Hz ⁴⁾

Subject to change without notice

To:

From:

14.03.2026
Page 7 of 11

VAP 11.15.3 – vap.danfoss.com



Subject:

Oil temperature sensor (Pt1000, for external evaluation) ³⁾

Hot gas temperature sensor (Pt1000, for external evaluation) ³⁾

Thermal protection thermostat per cylinder cover

USB converter for INT69 G Diagnose and INT69 GTML Diagnose ⁴⁾

Additional fan
230 V AC - 1 - 50 Hz, 97 W, IP44
230 V AC - 1 - 60 Hz, 128 W ⁴⁾

Intermediate adapter for discharge line valve ⁴⁾

Step protection

4 anti-vibration pads enclosed

Special voltage and/or frequency (on request)

-
- 1) Only with additional adapter possible
 - 2) Capacity regulator premounted, control unit enclosed
 - 3) Mounted
 - 4) Enclosure

Subject:

Dimensions and connections

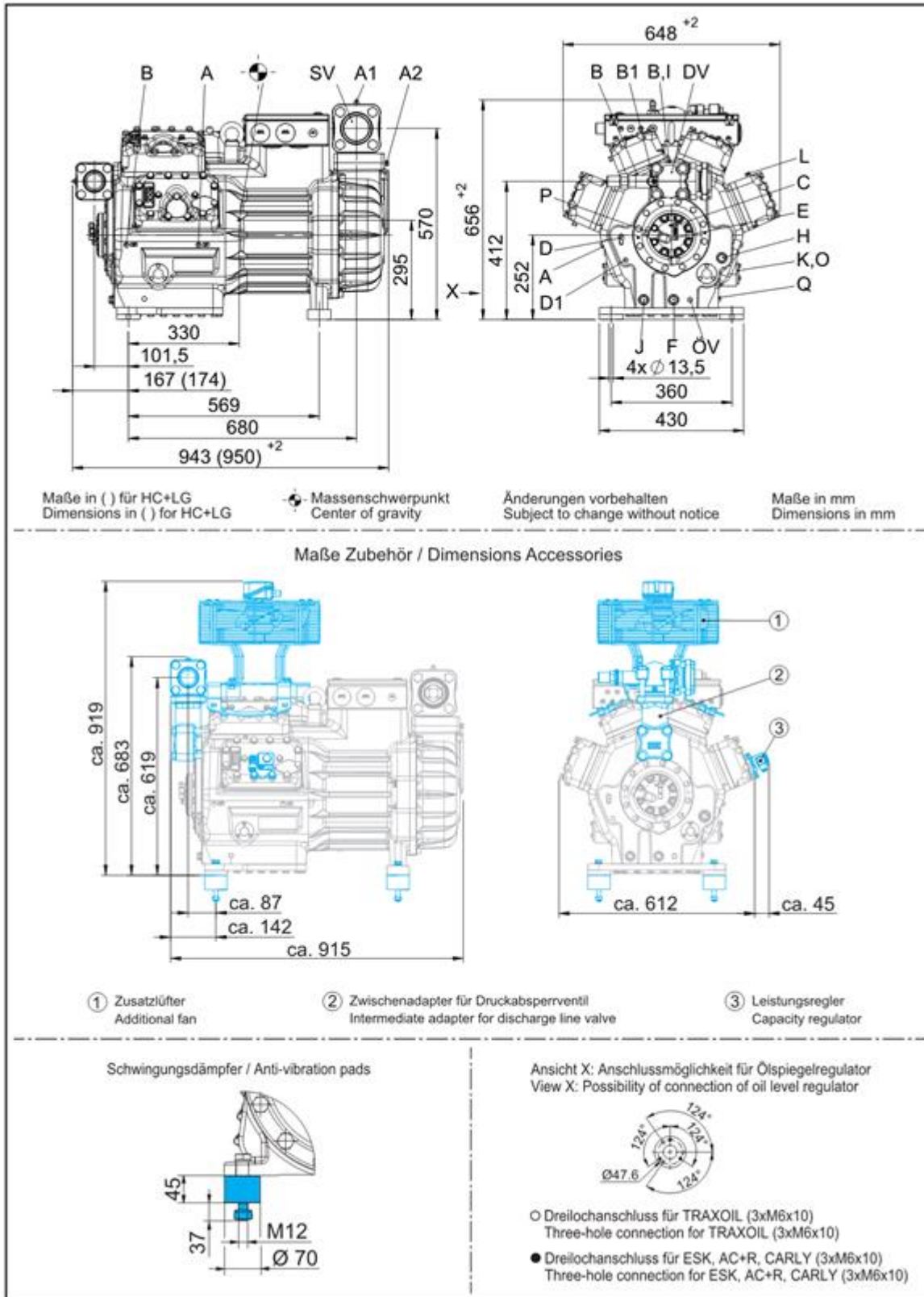

Subject to change without notice

To:

From:

14.03.2026
 Page 9 of 11

BOCK® HGX88e/2400-4 S

Engine: 380-420V Y/YY -3- 50Hz PW

Refrigerant: R452A

**Subject:**

SV	Suction line valve, tube \varnothing ¹⁾	76 mm - 3 1/8 "
DV	Discharge line valve, tube \varnothing ¹⁾	54 mm - 2 1/8 "
A	Connection suction side, not lockable	1/8 " NPTF
A1	Connection suction side, lockable	7/16 " UNF
A2	Connection suction side, not lockable	1/4 " NPTF
B	Connection discharge side, not lockable	1/8 " NPTF
B1	Connection discharge side, lockable	7/16 " UNF
C	Connection oil pressure safety switch OIL	7/16 " UNF
D	Connection oil pressure safety switch LP	7/16 " UNF
D1	Connection oil return from oil separator	1/4 " NPTF
E	Connection oil pressure gauge	7/16 " UNF
F	Oil drain	M 22 x 1.5
H	Oil charge plug	M 22 x 1.5
I	Connection hot gas temperature sensor	1/8 " NPTF
J	Connection oil sump heater	M 22 x 1.5
K	Sight glass	3 x M 6
L	Connection thermal protection thermostat	1/8 " NPTF
O	Connection oil level regulator	3 x M 6
ÖV	Connection oil service valve	1/4 " NPTF
P	Connection oil differential pressure sensor	M 20 x 1.5
Q	Connection oil temperature sensor	1/8 " NPTF

1) Brazing connection

Subject to change without notice

To:

From:

14.03.2026
Page 10 of 11VAP 11.15.3 – vap.danfoss.com

BOCK® HGX88e/2400-4 S
Engine: 380-420V Y/YY -3- 50Hz PW
Refrigerant: R452A



Subject:

Product photo

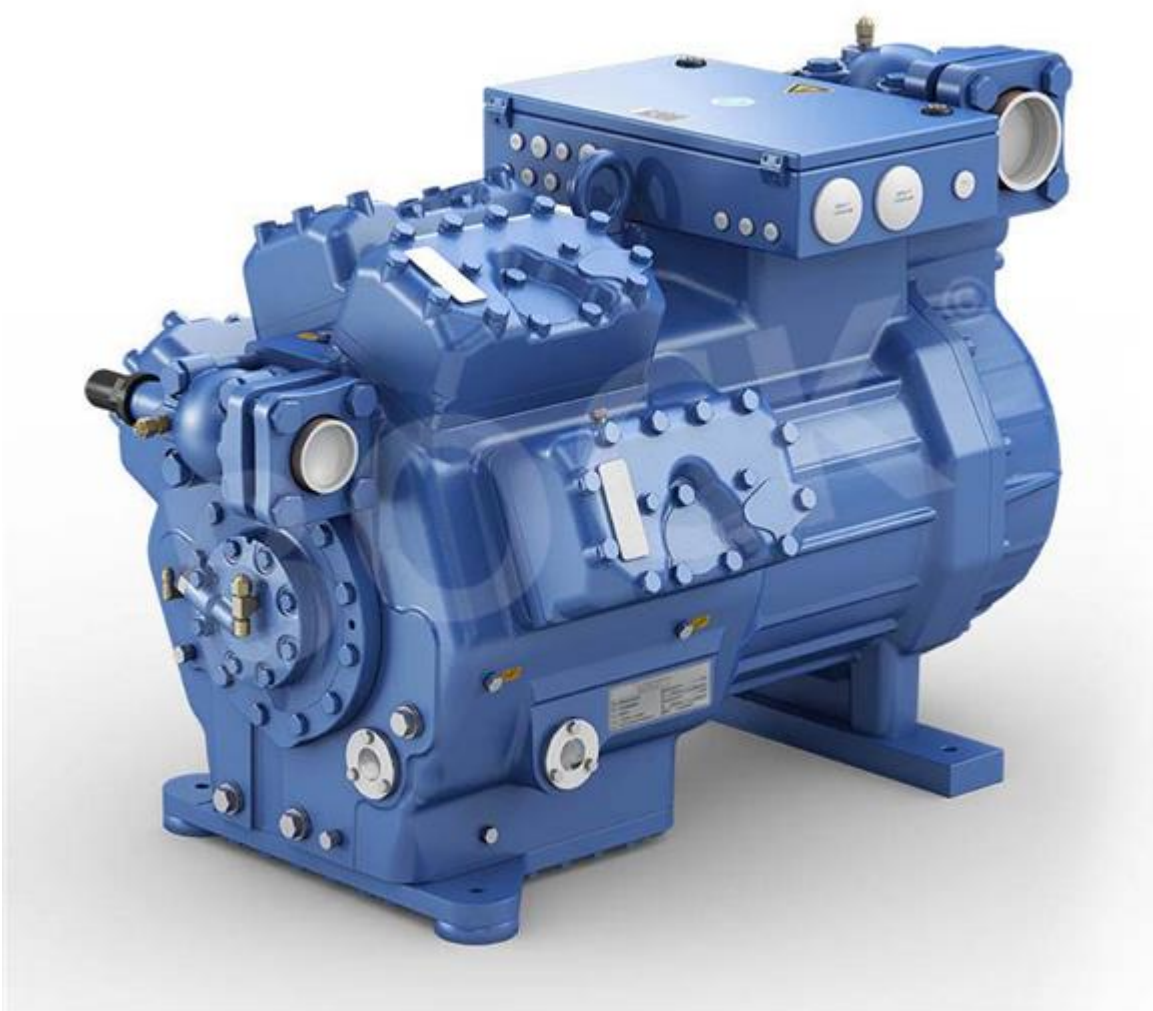

Subject to change without notice

To:

From:

14.03.2026
Page 11 of 11

VAP 11.15.3 – vap.danfoss.com