



**Subject:**

---

**Performance data**

**Application: Refrigeration & AC**

Refrigerant	R513A	Compressor refrigeration capacity	72.90 kW
Reference temperature	Dew point	Evaporator refrigeration capacity	72.90 kW
Power supply	50 Hz, 400 V	Power consumption	31.10 kW
Supply frequency	50 Hz	Current draw (400 V)	63.70 A
Evaporating temperature	-10.0 °C	Coefficient of performance (COP/EER)	2.34
<i>Evaporating pressure (abs.)</i>	<i>2.23 bar</i>	Condensing capacity	105.00 kW
Condensing temperature	45.0 °C	Mass flow	0.623 kg/s
<i>Condensing pressure (abs.)</i>	<i>12.17 bar</i>	Discharge end temperature	67.4 °C <sup>1)</sup>
Suction gas superheat	8 K		
Subcooling (outside cond.)	0 K		
Usable superheat	100%		

*Preliminary capacity data.*

- 
- 1) The stated value of the discharge end temperature is a mere calculated value. Additional cooling and heat dissipation are not considered. Deviations (particularly in deep freezing applications) from the real measured discharge temperature during operation are possible.

**Subject:**

---

## Operating limits

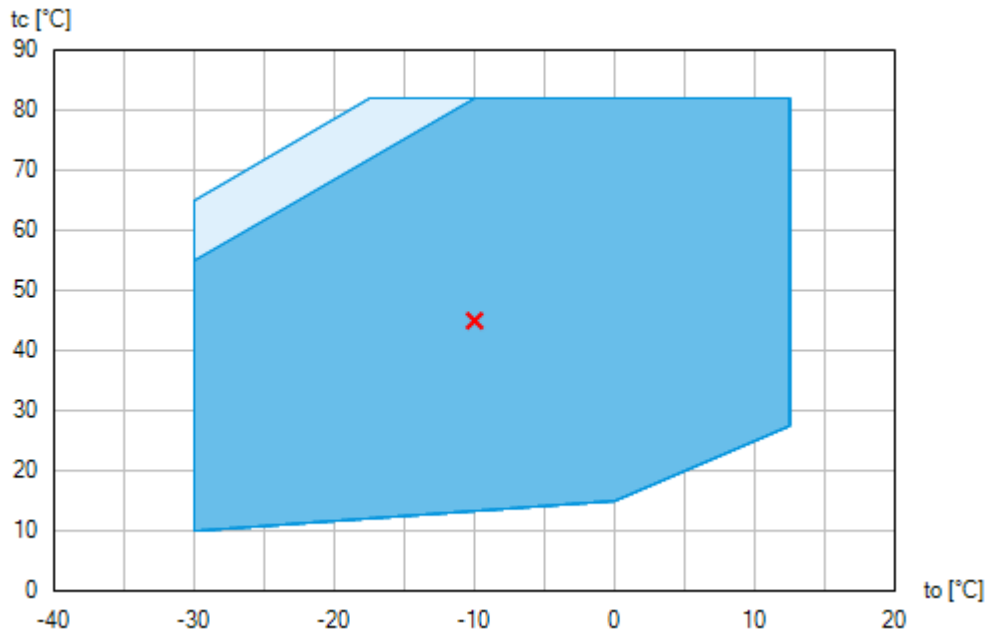

-  Unlimited application range
-  Supplementary cooling or reduced suction gas temperature ( $\Delta t_{oh} < 20K$ )

Compressor operation is possible within the limits shown on the diagrams of application. Please note the coloured areas. Compressor application limits should not be chosen for design purposes or continuous operation. Axis values refer to dew point (saturated vapour line).

**Subject:**

**Technical data**

Number of cylinders / Bore / Stroke	8 / 80 mm / 68 mm
Displacement 50/60 Hz (1450/1740 <sup>1</sup> /min)	237,90 / 285,50 m <sup>3</sup> /h
Voltage <sup>1)</sup>	380-420V Y/YY -3- 50Hz PW
	440-480V Y/YY -3- 60Hz PW
Winding divided into	50% / 50%
Max. working current <sup>2)</sup>	116.0 A
Max. power consumption <sup>2)</sup>	67.1 kW
Starting current (rotor blocked) <sup>2)</sup>	433.0 / 610.0 A
Motor protection	INT69 G
Protection terminal box	IP 65
Weight	455 kg
Frequency range <sup>3)</sup>	25 - 60 Hz
Max. permissible overpressure (g) (LP/HP) <sup>4)</sup>	19 / 28 bar
Connection suction line SV	76 mm - 3 1/8 "
Connection discharge line DV	54 mm - 2 1/8 "
Lubrication	Oil pump
Oil type R134a, R404A, R407A/C/F, R448A, R449A, R450A, R513A	BOCKlub E55
Oil type R22	BOCKlub A46
Oil charge	9,6 Ltr.
Oil sump heater	230 V - 1 - 50/60 Hz, 200 W
Dimensions Length / Width / Height	943 / 648 / 656 mm
Sound power level L <sub>WA</sub> <sup>5)</sup>	89 dB(A) @ -35 °C / +40 °C
	86 dB(A) @ -10 °C / +45 °C
Sound pressure level L <sub>pA</sub> <sup>5)</sup>	75 dB(A) @ -35 °C / +40 °C
	72 dB(A) @ -10 °C / +45 °C

1) Tolerance (± 10%) relates to the mean value of the voltage range. Other voltages and current types on request

All data are based on voltage rms values

PW = part winding, motors for part winding starting  
 (no start unloaders required)  
 Designs for Y/D on request

Subject to change without notice



**Subject:**

---

- 2) - The stated value for the max. power consumption is valid for the adjusted power supply.
  - Starting current (rotor blocked):
    - Part winding (PW) motors: Winding 1 / Winding 1+2
    - Delta/Star ( $\Delta/Y$ ) motors:  $\Delta / Y$
  - Take account of the max. operating current / max. power consumption for designing motor contractors, feed lines, fuses and motor protection switches. Motor contractors: Consumption category AC3.
- 3) The maximum permissible working current of the compressor ( $I_{max}$ ) must not be exceeded. Take account of the guidelines for use of frequency inverter (see compressor assembly instruction or selection software).
- 4) LP = Low pressure  
HP = High pressure
- 5) Declared dual-number noise emission values are in accordance with ISO 4871. The corresponding uncertainty to the sound power level is  $K_{WA} = 2,5$  dB and to the sound pressure level is  $K_{pA} = 2,5$  dB. The values are valid for 50 Hz with the refrigerant R404A at the standard rating points according to EN 12900.
  - A-weighted sound power level  $L_{WA}$  (re 1 pW), in decibel. To determine the values, measurement methods of the ISO 3740 standard with accuracy class 2 or higher were used .
  - A-weighted sound pressure level  $L_{pA}$  (re 20  $\mu$ Pa), in decibel. The values are calculated from the sound power level in accordance with ISO 11203:  $L_{pA} = L_{WA} - Q_2$  at a distance of  $d = 1$  m to the reference box.

Subject to change without notice

---

To:

From:

14.03.2026  
Page 4 of 11



**Subject:**

**Performance data table**

Application: Refrigeration & AC  
 Reference temperature: Dew point  
 Supply frequency: 50 Hz  
 Voltage: 400 V  
 Suction gas superheat: 8 K  
 Subcooling (outside cond.): 0 K

tc [°C]		to [°C]									
		10.0	5.0	0.0	-5.0	-10.0	-15.0	-20.0	-25.0	-30.0	-35.0
10.0	Q [W] P [kW] I [A]									44800 15.90 48.20	
15.0	Q [W] P [kW] I [A]			173000 23.40 55.20	141000 23.30 55.00	113000 22.60 54.30	89600 21.40 53.10	70100 19.90 51.70	54100 18.10 50.10	41500 16.30 48.50	
20.0	Q [W] P [kW] I [A]		200000 26.00 57.90	165000 26.00 57.90	134000 25.40 57.20	108000 24.20 56.00	84500 22.60 54.40	65700 20.80 52.50	50300 18.80 50.70	38000 16.70 48.90	
25.0	Q [W] P [kW] I [A]	228000 28.90 61.10	190000 29.10 61.30	156000 28.50 60.70	127000 27.40 59.40	101000 25.80 57.60	79200 23.80 55.60	61100 21.70 53.40	46300 19.30 51.20	34500 17.00 49.20	
30.0	Q [W] P [kW] I [A]	217000 32.40 65.20	180000 32.00 64.70	147000 30.90 63.50	119000 29.30 61.60	94100 27.30 59.30	73500 25.00 56.80	56300 22.50 54.20	42200 19.90 51.70	31000 17.30 49.40	
35.0	Q [W] P [kW] I [A]	204000 35.80 69.40	169000 34.80 68.20	138000 33.20 66.20	111000 31.20 63.70	87200 28.70 60.90	67700 26.00 57.90	51400 23.20 54.90	38100 20.30 52.10	27500 17.60 49.60	
40.0	Q [W] P [kW] I [A]	191000 39.00 73.60	157000 37.50 71.60	128000 35.40 68.90	102000 32.80 65.80	80100 30.00 62.40	61800 26.90 58.90	46500 23.80 55.50	34100 20.70 52.50	24300 17.70 49.80	
45.0	Q [W] P [kW] I [A]	178000 42.10 77.70	146000 40.00 74.90	118000 37.40 71.50	93300 34.40 67.70	72900 31.10 63.70	55800 27.70 59.80	41700 24.30 56.10	30300 20.90 52.70	21200 17.80 49.80	
50.0	Q [W] P [kW] I [A]	164000 44.90 81.70	134000 42.30 78.00	107000 39.20 73.90	84600 35.80 69.40	65700 32.10 64.90	50000 28.40 60.50	37100 24.70 56.40	26700 21.10 52.80	18500 17.70 49.80	
55.0	Q [W] P [kW] I [A]	150000 47.50 85.40	121000 44.40 80.90	96400 40.80 76.00	75800 37.00 70.90	58500 32.90 65.90	44200 28.90 61.10	32600 24.90 56.60	23300 21.00 52.80	16100 17.50 49.60	
60.0	Q [W] P [kW] I [A]	135000 49.90 88.90	109000 46.30 83.60	85900 42.20 78.00	67100 38.00 72.20	51400 33.60 66.60	38700 29.20 61.40	28400 24.90 56.70	20400 20.90 52.60	14200 17.20 49.30	
65.0	Q [W] P [kW] I [A]	120000 52.10 92.00	95800 47.90 86.00	75400 43.40 79.60	58500 38.70 73.30	44600 34.00 67.20	33400 29.30 61.50	24600 24.70 56.50	17800 20.50 52.30	12600 16.60 48.80	
70.0	Q [W] P [kW] I [A]	106000 54.00 94.80	83300 49.30 88.00	65000 44.40 80.90	50100 39.30 74.00	38000 34.20 67.40	28500 29.20 61.40	21100 24.40 56.10	15600 19.90 51.70		
75.0	Q [W] P [kW] I [A]	90500 55.60 97.20	70800 50.40 89.60	54800 45.00 81.90	41900 39.60 74.40	31800 34.10 67.30	24000 28.80 61.00	18100 23.80 55.50			

Subject to change without notice



**Subject:**

80.0	Q [W]	75800	58600	44800	34100	25900	19800				
	P [kW]	57.00	51.30	45.40	39.60	33.80	28.20				
	I [A]	99.20	90.80	82.40	74.40	66.90	60.30				

*Preliminary capacity data.*

Supplementary cooling or reduced suction gas temperature ( $\Delta t_{oh} < 20K$ )

- t<sub>o</sub>* Evaporating temperature
- t<sub>c</sub>* Condensing temperature
- Q* Compressor refrigeration capacity
- P* Power consumption
- I* Current draw

**Subject:**

---

**Scope of supply**

Semi-hermetic eight-cylinder reciprocating compressor with drive motor  
Single-section Compressor housing with hermetically integrated electric motor

Winding protection with PTC resistor sensors and electronic trigger unit INT69 G  
115-230 V AC, 50/60 Hz, IP00

Oil pump

Possibility of connection of oil level controllers ESK, AC+R or CARLY

Oil pump cover with screw-in option for oil differential pressure sensor DELTA-P II

Possibility of connection of oil level controllers Traxoil <sup>1)</sup>

Possibility for connection of oil pressure safety switch MP54

Oil charge:

HG: **BOCK**lub A46

HGX: **BOCK**lub E55

Three sight glasses

Pressure relief valve

Suction and discharge line valve

Inert gas charge

**Accessories**

Capacity regulator 110 V - 1 - 50/60 Hz, IP65  
1-3 capacity regulator = 75/50/25% residual capacity <sup>2)</sup>

Capacity regulator 230 V - 1 - 50/60 Hz, IP65  
1-3 capacity regulator = 75/50/25% residual capacity <sup>2)</sup>

Cylinder cover prepared for capacity regulator

Oil sump heater 230 V - 1 - 50/60 Hz, 200 W <sup>3)</sup>

Oil service valve <sup>3)</sup>

INT69 GTML Diagnose 115-230 V AC, 50/60 Hz, IP00, including oil differential pressure sensor INT250G,  
thermal protection thermostat per cylinder covers, (INT69 G not applicable)

Oil pressure safety switch MP54 230 V - 1 - 50/60 Hz, IP20 <sup>4)</sup>

Thermal protection thermostat per cylinder cover <sup>3)</sup>

Connection piece suction and discharge valve in welding design

Oil differential pressure sensor DELTA-P II 220-240 V - 1 - 50/60 Hz <sup>4)</sup>

Subject to change without notice



**Subject:**

---

Oil temperature sensor (Pt1000, for external evaluation) <sup>3)</sup>

Hot gas temperature sensor (Pt1000, for external evaluation) <sup>3)</sup>

Thermal protection thermostat per cylinder cover

USB converter for INT69 G Diagnose and INT69 GTML Diagnose <sup>4)</sup>

Additional fan  
230 V AC - 1 - 50 Hz, 97 W, IP44  
230 V AC - 1 - 60 Hz, 128 W <sup>4)</sup>

Intermediate adapter for discharge line valve <sup>4)</sup>

Step protection

4 anti-vibration pads enclosed

Special voltage and/or frequency (on request)

- 
- 1) Only with additional adapter possible
  - 2) Capacity regulator premounted, control unit enclosed
  - 3) Mounted
  - 4) Enclosure

**Subject:**

**Dimensions and connections**

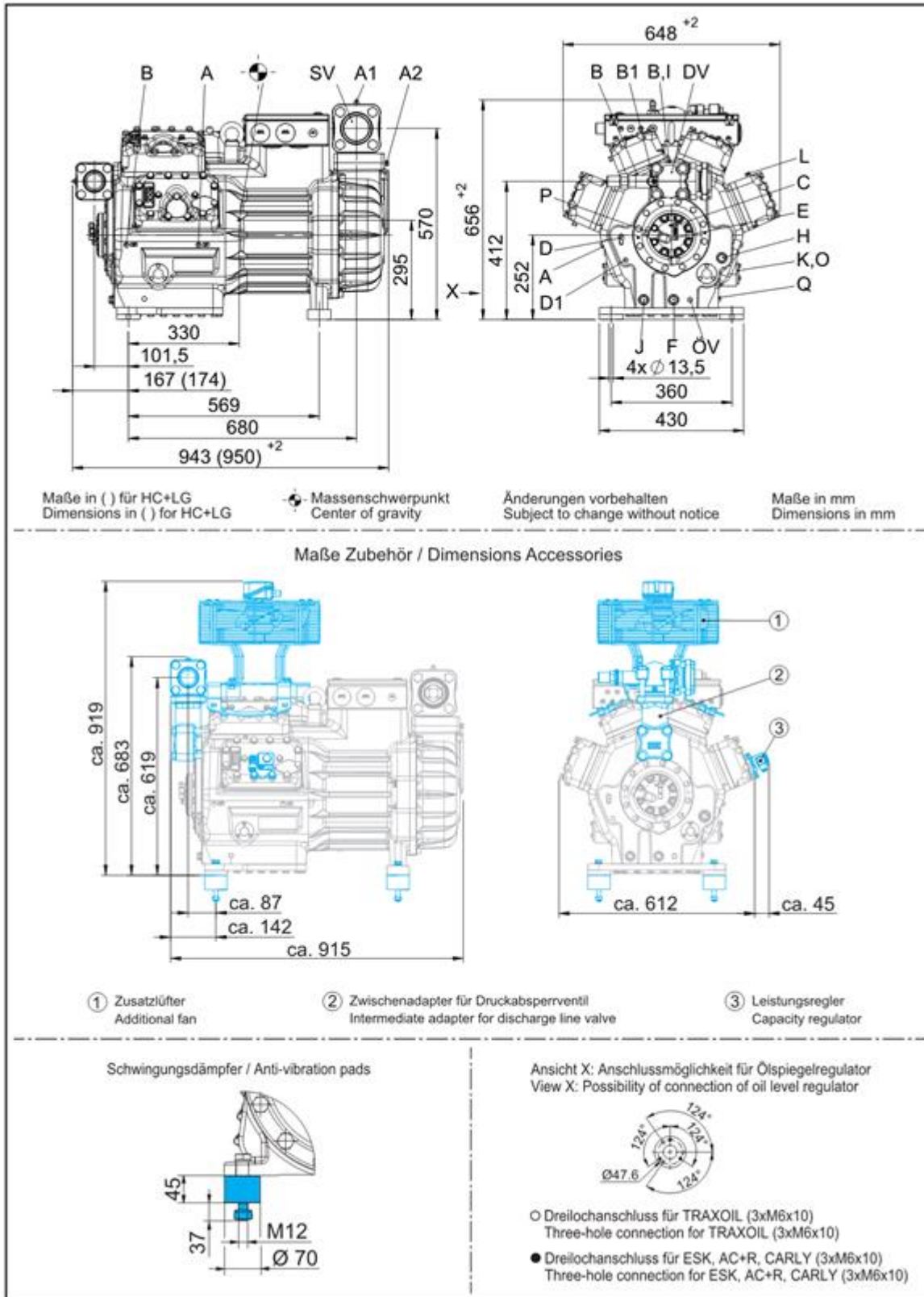

Subject to change without notice

To:

From:

14.03.2026  
 Page 9 of 11



**Subject:**

SV	Suction line valve, tube $\varnothing$ <sup>1)</sup>	76 mm - 3 1/8 "
DV	Discharge line valve, tube $\varnothing$ <sup>1)</sup>	54 mm - 2 1/8 "
A	Connection suction side, not lockable	1/8 " NPTF
A1	Connection suction side, lockable	7/16 " UNF
A2	Connection suction side, not lockable	1/4 " NPTF
B	Connection discharge side, not lockable	1/8 " NPTF
B1	Connection discharge side, lockable	7/16 " UNF
C	Connection oil pressure safety switch OIL	7/16 " UNF
D	Connection oil pressure safety switch LP	7/16 " UNF
D1	Connection oil return from oil separator	1/4 " NPTF
E	Connection oil pressure gauge	7/16 " UNF
F	Oil drain	M 22 x 1.5
H	Oil charge plug	M 22 x 1.5
I	Connection hot gas temperature sensor	1/8 " NPTF
J	Connection oil sump heater	M 22 x 1.5
K	Sight glass	-
L	Connection thermal protection thermostat	1/8 " NPTF
O	Connection oil level regulator	3 x M 6
ÖV	Connection oil service valve	1/4 " NPTF
P	Connection oil differential pressure sensor	M 20 x 1.5
Q	Connection oil temperature sensor	1/8 " NPTF

1) Brazing connection

**BOCK® HGX88e/2735-4**  
Engine: 380-420V Y/YY -3- 50Hz PW  
Refrigerant: R513A



**Subject:**

---

**Product photo**



---

Subject to change without notice

To:

From:

14.03.2026  
Page 11 of 11

VAP 11.15.3 – [vap.danfoss.com](http://vap.danfoss.com)