



Universal Controller

Universal electronic controller



UNIVERSAL
controller



USER MANUAL

→ **LEGGI E CONSERVA
QUESTE ISTRUZIONI** ←
**READ AND SAVE
THESE INSTRUCTIONS**



CAREFULLY READ THE

TEXT

Universal Controller

Up to date version available on
www.ksa.carel.com

GENERAL WARNINGS



CAREL bases the development of its products on decades of experience in HVAC, on continuous investments in technological innovations to products, procedures and strict quality processes with in-circuit and functional testing on 100% of its products, and on the most innovative production technology available on the market. CAREL and its subsidiaries/affiliates nonetheless cannot guarantee that all the aspects of the product and the software included with the product respond to the requirements of the final application, despite the product being developed according to start-of-the-art techniques. The customer (manufacturer, developer or installer of the final equipment) accepts all liability and risk relating to the configuration of the product in order to reach the expected results in relation to the specific final installation and/or equipment. CAREL may, based on specific agreements, act as a consultant for the successful commissioning of the final unit/application, however in no case does it accept liability for the correct operation of the final equipment/system. The CAREL product is a state-of-the-art product, whose operation is specified in the technical documentation supplied with the product or can be downloaded, even prior to purchase, from the website www.carel.com. Each CAREL product, in relation to its advanced level of technology, requires setup/configuration/programming/commissioning to be able to operate in the best possible way for the specific application. Failure to complete such operations, which are required/indicated in the user manual, may cause the final product to malfunction; CAREL accepts no liability in such cases. Only qualified personnel may install or carry out technical service on the product. The customer must only use the product in the manner described in the documentation relating to the product. In addition to observing any further warnings described in this manual, the following warnings must be heeded for all CAREL products:

- prevent the electronic circuits from getting wet. Rain, humidity and all types of liquids or condensate contain corrosive minerals that may damage the electronic circuits. In any case, the product should be used or stored in environments that comply with the temperature and humidity limits specified in the manual.
- do not install the device in particularly hot environments. Too high temperatures may reduce the life of electronic devices, damage them and deform or melt the plastic parts. In any case, the product should be used or stored in environments that comply with the temperature and humidity limits specified in the manual.
- do not attempt to open the device in any way other than described in the manual.
- do not drop, hit or shake the device, as the internal circuits and mechanisms may be irreparably damaged;
- do not use corrosive chemicals, solvents or aggressive detergents to clean the device.
- do not use the product for applications other than those specified in the technical manual.

All of the above suggestions likewise apply to the controllers, serial cards, programming keys or any other accessory in the CAREL product portfolio. CAREL adopts a policy of continual development. Consequently, CAREL reserves the right to make changes and improvements to any product described in this document without prior warning. The technical specifications shown in the manual may be changed without prior warning. The liability of CAREL in relation to its products is specified in the CAREL general contract conditions, available on the website www.carel.com and/or by specific agreements with customers; specifically, to the extent where allowed by applicable legislation, in no case will CAREL, its employees or subsidiaries/affiliates be liable for any lost earnings or sales, losses of data and information, costs of replacement goods or services, damage to things or people, downtime or any direct, indirect, incidental, actual, punitive, exemplary, special or consequential damage of any kind whatsoever, whether contractual, extra-contractual or due to negligence, or any other liabilities deriving from the installation, use or impossibility to use the product, even if CAREL or its subsidiaries/affiliates are warned of the possibility of such damage.

DISPOSAL

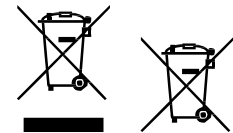

Fig. 1 Fig. 2

INFORMATION FOR USERS ON THE CORRECT HANDLING OF WASTE ELECTRICAL AND ELECTRONIC EQUIPMENT (WEEE)

The product is made up of metal parts and plastic parts. In reference to European Union directive 2002/96/EC issued on 27 January 2003 and related national legislation, please note that:

- WEEE cannot be disposed of as municipal waste and such waste must be collected and disposed of separately;
- the public or private waste collection systems defined by local legislation must be used. In addition, the equipment can be returned to the distributor at the end of its working life when buying new equipment;
- the equipment may contain hazardous substances: the improper use or incorrect disposal of such may have negative effects on human health and on the environment;
- the symbol (crossed-out wheeled bin) shown on the product or on the packaging and on the technical leaflet indicates that the equipment has been introduced onto the market after 13 August 2005 and that it must be disposed of separately;
- in the event of illegal disposal of electrical and electronic waste, the penalties are specified by local waste disposal legislation.

Warranty on materials: 2 years (from production date, excluding consumables).

Approval: the quality and safety of CAREL S.P.A. products are guaranteed by the ISO 9001 certified design and production system.



READ CAREFULLY IN THE TEXT!

Separate as much as possible the probe and digital input cables from cables to inductive loads and power cables, so as to avoid possible electromagnetic disturbance. Never run power cables (including the electrical panel cables) and signal cables in the same conduits.

Key to the symbols:

Caution: to bring critical issues to the attention of those using the product. Notice: to focus attention on important topics; in particular the practical application of the various product functions.

Notice: to focus attention on important topics; in particular the practical application of the various product functions.

Caution: this product is to be integrated and/or incorporated into the final apparatus or equipment. Verification of conformity to the laws and technical standards in force in the country where the final apparatus or equipment will be operated is the manufacturer's responsibility. Before delivering the product, Carel has already completed the checks and tests required by the relevant European directives and harmonised standards, using a typical test setup, which however cannot be considered as representing all possible conditions of the final installation.

Contents

1. INTRODUCTION.....	5
1.1 Main functions	5
1.2 Models	6
1.3 Accessories	6
1.3.1 USB/RS485 converter (CVSTDUMOR0).....	6
1.3.2 Connector kit.....	6
2. INSTALLATION	7
2.1 Warnings	7
2.2 Panel version	7
2.2.1 Dimensions (mm).....	7
2.2.2 Mounting.....	7
2.2.3 Removal.....	8
2.3 DIN rain version	8
2.3.1 Dimensions (mm).....	8
2.3.2 Removal.....	8
2.4 Electrical installation	9
2.4.1 Description of the terminals.....	10
2.5 Probe / digital input connection.....	11
2.6 Serial port connections	12
2.7 Positioning inside the panel	12
3. USER INTERFACE	13
3.1 Introduction.....	13
3.2 User terminal	13
3.2.1 Keypad.....	13
3.2.2 Icons.....	13
3.3 Display main page view	14
3.3.1 Main unit values.....	15
3.3.2 Direct access parameters	17
3.3.3 Access the programming menu.....	18
3.3.4 Programming menu.....	19
4. COMMISSIONING	20
4.1 Applica app.....	20
4.1.1 Connection to the controller.....	20
4.2 Configuration procedure	21
4.2.1 Main sections.....	21
4.2.2 Parameter list	24
4.2.3 Create a unit configuration.....	25
4.2.4 FW update.....	26
4.3 Applica Desktop.....	27
4.3.1 Connection to the controller.....	27
4.4 Setup procedure with Applica Desktop	28
4.4.1 Create a unit configuration.....	28
4.4.2 Date and time setting.....	29
4.4.3 Parameter list	30
4.4.4 FW update.....	30
5. FUNCTIONS.....	31
5.1 Standard operating modes	31
5.1.1 Mode 1: Direct (B000=1).....	32
5.1.2 Mode 2: Reverse (B000=2).....	33
5.1.3 Mode 3: Neutral zone (B000=3).....	34
5.1.4 Mode 6: Direct/reverse changeover from DI1 (B000=6).....	35
5.1.5 Mode 7: Set point and differential from DI1 (Direct) (B000=7).....	36
5.1.6 Mode 8: Set point and differential from DI1 (Reverse) (B000=8).....	37
5.1.7 Mode 9: Direct/reverse with two set points (B000=9).....	38
5.1.8 Mode 10: 3-position valve (B000=10).....	39
5.2 Operating modes with probe 2 (Prb2).....	41
5.2.1 Differential operation (Prb1-Prb2) (B012=1).....	41
5.2.2 Enable regulation based on absolute set point (B012=5).....	42
5.2.3 Enable regulation based on set point differential (B012=6).....	42
5.2.4 Independent operation (circuit 1 + circuit 2) (B012=7).....	43
5.2.5 Control on the higher probe value (B012=8).....	44
5.2.6 Control on the lower probe value (B012=9).....	44
5.2.7 Set point on probe 2 (B012=10).....	45
5.2.8 Automatic summer/winter changeover from probe 2 (B012=11).....	45

5.3 Probe 3 functions (B036).....	46
5.3.1 Summer compensation (B036=1).....	46
5.3.2 Winter compensation (B036=2).....	47
5.3.3 Summer/winter compensation (B036=3).....	48
5.3.4 Read-only (B036=4).....	48
5.4 Special operation (B000=0).....	49
5.5 Scheduler.....	50
5.6 Soft start.....	51
5.7 Output rotation.....	51
6. PARAMETER TABLE.....	52
6.1 Main page (press DOWN briefly).....	52
6.2 Main page (press PRG briefly).....	53
6.3 Input/output configuration.....	53
6.4 Control configuration.....	55
6.4.1 PID parameter table (B004=1).....	56
6.4.2 Special parameter table (B000=0).....	58
6.5 Alarm configuration.....	61
6.6 Settings.....	61
6.7 Clock.....	62
6.8 Scheduler.....	62
7. SUPERVISION.....	64
7.1 Unit on/off management from BMS.....	64
7.2 Supervisor model for Boss and PlantVisorPRO range.....	64
8. ALARMS AND SIGNALS.....	65
8.1 Types of alarms.....	65
8.2 Override regulation outputs.....	65
8.3 Alarm list.....	66
9. TECHNICAL SPECIFICATIONS.....	67
9.1 Connector/cable table.....	68
10. RELEASE NOTES.....	69

1. INTRODUCTION

The Universal Controller is a configurable device for regulation of the main physical measurements (temperature, pressure, humidity) in air conditioning, refrigeration and heating units. ON/OFF, proportional, and PID regulation can be managed.

If a second probe is connected, differential regulation can be managed with reference to the main probe, or a second independent regulation function can be activated with dedicated set point, differential and outputs.

If a third probe is connected, summer/winter compensation can be managed for adjusting the current set point.

The integrated clock and scheduler can be used to set when the unit should change the regulation set point, based on the set comfort and economy modes, or when to switch off.

The user terminal features wireless connectivity via Bluetooth with mobile devices and is available on both the panel and DIN rail models. CAREL's "APPLICA" app, available on Google Play for the Android operating system and App Store for Apple iOS, makes it easier to configure parameters and commission the unit in the field.

1.1 Main functions

Ref.	Description
Main features	1 analogue input: NTC, PT1000, 0-10 VDC, 0-5 VDC ratiometric, 0-20 mA, 4-20 mA
	2 analogue inputs: NTC, 0-5 VDC ratiometric, 0-20 mA, 4-20 mA
	2 voltage-free contact inputs
	2 x 0-10 V analogue outputs
	5 x 5 A digital outputs
Hardware	Panel mounting model
	DIN rail model
User interface	2-row, 7-segment LED display for panel and DIN rail models
	Communication with APPLICA app (BTLE compatible) for mobile devices
Control	1 main regulation loop, ON/OFF, proportional, PID referring to probe 1
	1 loop for additional logic or second independent circuit referring to probe 2
	1 loop for set point compensation logic referring to probe 3
	Special mode for setting independent regulation for individual digital and analogue outputs
Programming with time bands	RTC with date/time retention after power off for 72 h
	3 daily programs, 4 time bands per program
	Off, Comfort, Economy mode
Alarms	Management of vacation periods and special days
	Management of automatic and manual reset according to alarm severity
Connectivity/supervision	Alarm log (up to 20 events): alarm and reset date and time recorded
	RS485 serial port
Modbus RTU	Serial address from 1 to 247
	Baud rate up to 375000 bit/s
	Parity (none, even, odd) and stop bits (1 or 2)
	Fixed 8 bit data bits

1.2 Models



DIN rail model

Part number	Description
-------------	-------------

U20R00UC00200	Panel model
U20R00UC00250	DIN rail model



Panel model

1.3 Accessories

1.3.1 USB/RS485 converter (CVSTDUMOR0)



Electronic device for interfacing an RS485 network to a personal computer via the USB port.
See technical leaflet +050000590.

1.3.2 Connector kit

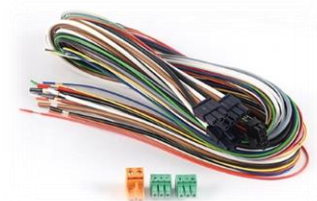

Part number	Description
-------------	-------------

UCHCOND010	CONN. AND CABLE KIT UCHILLER DIN MOLEX/FREE 100CM
UCHCOND030	CONN. AND CABLE KIT UCHILLER DIN MOLEX/FREE 300CM
UCHCONP010	CONN. AND CABLE KIT UCHILLER PANEL MOLEX/FREE 100CM
UCHCONP030	CONN. AND CABLE KIT UCHILLER PANEL MOLEX/FREE 300CM

2. INSTALLATION

2.1 Warnings

- ⚠ Caution: avoid installing the controller in environments with the following characteristics:
- temperature and humidity that do not comply with the ambient operating conditions (see "Technical specifications");
 - strong vibrations or knocks;
 - exposure to water sprays or condensate;
 - exposure to aggressive and polluting atmospheres (e.g.: sulphur and ammonia gases, saline mist, smoke) which may cause corrosion and/or oxidation;
 - strong magnetic and/or radio frequency interference (thus avoid installation near transmitting antennae);
 - exposure to direct sunlight and the elements in general;
 - wide and rapid fluctuations in ambient temperature;
 - exposure to direct sunlight, the weather in general and dust (formation of corrosive patina with possible oxidation and reduction of insulation).

2.2 Panel version

2.2.1 Dimensions (mm)

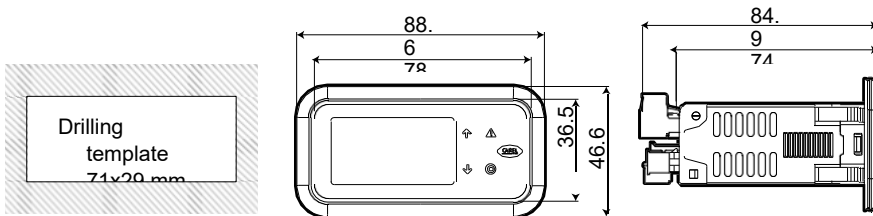

2.2.2 Mounting

⚠ Caution: before carrying out any maintenance, disconnect the controller from the power supply by moving the main system switch to "off".

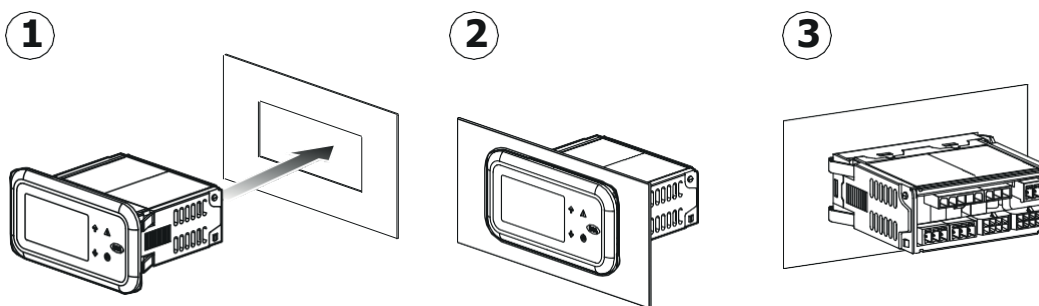

1. Place the controller in the opening, pressing lightly on the side anchoring tabs.
2. Then press on the front until fully inserted (the side tabs will bend, and the catches will attach the controller to the panel).

- ⚠ Caution: IP65 front protection is guaranteed only if the following conditions are met:
- maximum deviation of the rectangular opening from flat surface: ≤ 0.5 mm;
 - thickness of the electrical panel sheet metal: 0.8-2 mm;
 - maximum roughness of the surface where the gasket is applied: ≤ 120 μ m.

📌 Note: the thickness of the sheet metal (or material) used to make the electrical panel must be adequate to ensure safe and stable mounting of the product.

2.2.3 Removal

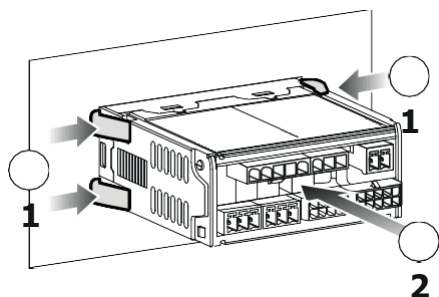

Open the electrical panel and from the back press on the anchoring tabs and then push the controller to remove it:

Gently press the side anchoring tabs on the controller;
Exert slight pressure on the controller until it is removed.

⚠ Caution:
the operation does not require the use of a screwdriver or other tools.

2.3 DIN rail version

2.3.1 Dimensions (mm)

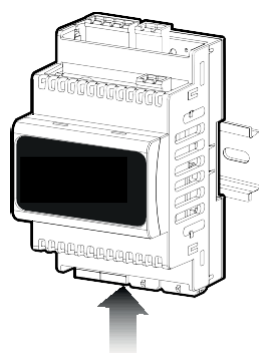
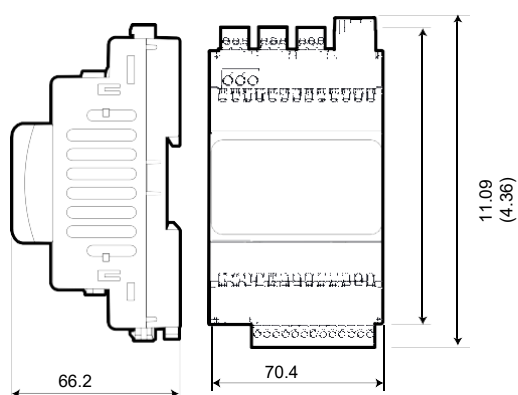

Apply slight pressure to the controller resting on the DIN rail until the rear tab clicks into place.

2.3.2 Removal

Use a screwdriver as a lever in the hole to lift and release the tab.
The tab is held in the locked position by return springs.

2.4 Electrical installation

⚠ Caution:

before carrying out any maintenance, disconnect the controller from the power supply by moving the main system switch to "off".

⚠ Caution:

when laying the wiring, "physically" separate the power part from the regulation part. The proximity of these two sets of wires will, in most cases, cause problems of induced disturbance or, over time, malfunctions or damage to the components.

The ideal solution is to house these two circuits in two separate cabinets. Sometimes this is not possible, and therefore the power part and the regulation part must be installed in two separate areas inside the same panel.

For the regulation signals, it is recommended to use shielded cables with twisted wires. If the regulation cables have to cross over the power cables, the intersections must be as near as possible to 90 degrees, always avoiding running the regulation cables parallel to the power cables.

Pay attention to the following warnings:

- use cable ends suitable for the corresponding terminals. Loosen each screw and insert the cable ends, then tighten the screws. When the operation is completed, slightly tug the cables to check they are sufficiently tight;
- separate as much as possible the probe signal, digital input and serial line cables from the cables carrying inductive loads and power cables to avoid possible electromagnetic disturbance. Never run power cables (including the electrical cables) and probe signal cables in the same conduits. do not install the probe cables in the immediate vicinity of power devices (contactors, circuit breakers or similar);
- reduce the path of the probe cables as much as possible, and avoid spiral paths that enclose power devices;
- avoid touching or nearly touching the electronic components fitted on the boards to avoid electrostatic discharges (extremely damaging) from the operator to the components;
- do not secure the cables to the terminals by pressing the screwdriver with excessive force, to avoid damaging the controller: maximum tightening torque: 0.22-0.25 N•m.
- for applications subject to considerable vibrations (1.5 mm pk-pk 10/55 Hz), secure the cables connected to the controller around 3 cm from the connectors using clamps;
- all the extra low voltage connections (analogue and digital inputs, analogue outputs, serial bus connections, power supplies) must have reinforced or double insulation from the mains network.

2.4.1 Description of the terminals

Panel version

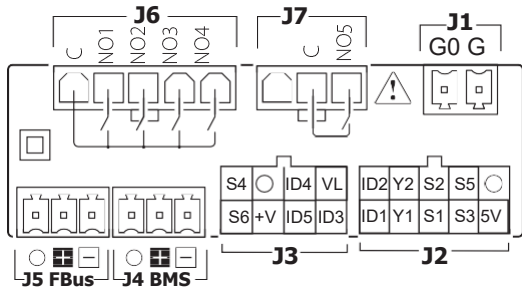

DIN rail version

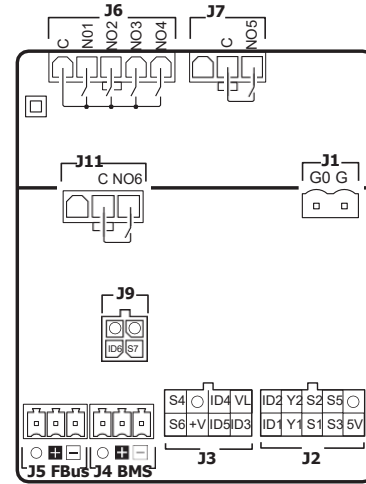

Ref.	Description	
J1	G 24 VAC/VDC power supply	
	G0 Neutral	
J2	5 V Ratiometric probe power supply	
	S3 Analogue input 3 (not used)	
	S1 Analogue input 1 (not used)	
	Y1 Analogue output 1	
	ID1 Digital input 1	
	O Common GND	
	S5 Analogue input 5 (probe 3)	
	S2 Analogue input 2 (not used)	
	Y2 Analogue output 2	
	ID2 Digital input 2	
	ID3 Digital input 3 (not used)	
	ID5 Digital input 5 (not used)	
	+V Power supply to 4-20 mA active probes	
J3	S6 Analogue input 6 (probe 1)	
	VL N/A	
	ID4 Digital input 4 (not used)	
	O Common GND	
	S4 Analogue input 4 (probe 2)	
	J4	- BMS port (RS485) Rx/Tx-
		+ BMS port (RS485) Rx/Tx+
O BMS port (RS485) GND		

Ref.	Description
J5	- Fieldbus port (RS485) Rx/Tx-
	+ Fieldbus port (RS485) Rx/Tx+
	O Fieldbus port (RS485) GND
J6	C Common for relays 1, 2, 3, 4
	NO1 Digital output 1
	NO2 Digital output 2
	NO3 Digital output 3
J7	NO4 Digital output 4
	C Common for relay 5
	NO5 Digital output 5 (alarm)
	J9
ID6 Digital input 6 (not used)	
O Common GND	
J11	N/A
	C Common for relay 6
	CN6 Digital output 6 (not used)

2.6 Serial port connections

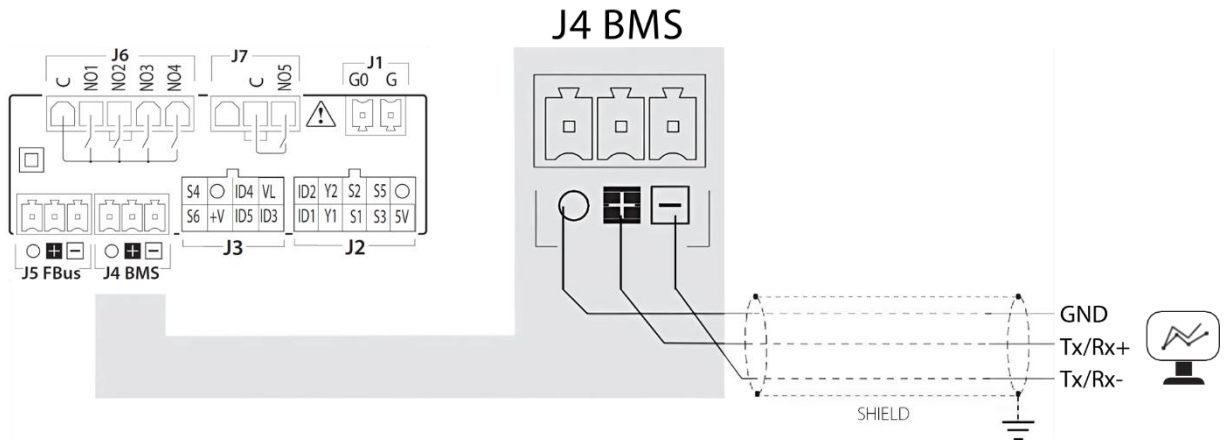

Communication parameters

Code	Description	Value
Hd00	BMS address	1
Hd01	BMS baud rate 0=1200, 1=2400, 2=4800, 3=9600, 4=19200, 5=38400, 6=57600, 7=115200, 8=375000	4
Hd02	BMS network settings 0=8-NONE-1, 1=8-NONE-2, 2=8-EVEN-1, 3=8-EVEN-2, 4=8-ODD-1, 5=8-ODD-2	1

For further information see paragraph 7

2.7 Positioning inside the panel

The position of the controller in the electrical cabinet must be chosen so as to guarantee correct physical separation from the power components (solenoids, contactors, actuators, inverters, ...) and the connected cables. Proximity to such devices/cables may create random malfunctions that are not immediately evident. The structure of the panel must allow the correct flow of cooling air.

3. USER INTERFACE

3.1 Introduction

The Universal Controller uses the user terminal to display the alarms, the main variables and to set the unit set points (User level) and manual functions (Service level).

The terminal has a two-row 7-segment LED display: the top row shows 3 digits with sign and decimal point, while the bottom row shows 4 digits with sign. There is a buzzer, 14 operating icons and 4 buttons for scrolling and setting the parameters.

The terminal has Bluetooth connectivity to interact with mobile devices (installed with the Carel "Applica" app, available on Google Play for Android operating systems).

Notice:

- Access levels: User; Service; Manufacturer. See the parameter table in paragraph 6 for further information.
- The information and parameters accessible from the terminal and from the Applica app depend on the access level and the unit configuration parameters.

3.2 User terminal



Built-in regulation interface

3.2.1 Keypad

Button	Description	Function
	UP	When scrolling: Previous menu/parameter When programming: Increase value
	DOWN	When scrolling: Next menu/parameter When programming: Decrease value On the main page: Display status and probes
	ALARM	Pressed briefly: View active alarms and mute buzzer Press and hold (3s): Reset alarms
	PRG	When scrolling: Access menus/parameters When programming: Confirm value Pressed briefly: Access the main commands Press and hold (3s): Access the main menu

3.2.2 Icons

The icons indicate the operating status and operating modes, as shown in the following table.

Button	Description	Function
	HEAT	Heating regulation active: Winter season or reverse logic
	COOL	Cooling regulation active: Summer season or direct logic
	ALARM	White icon: No active alarms Flashing red icon: Alarms in progress not displayed Red icon: Alarms in progress

3.3 Display main page view

On startup, the user terminal will briefly display the current controller firmware revision. After that, the main page will be displayed.



The value displayed on the first row can be set by the user via parameter B020:

Code	Description	Default
B020	Display: 0=Probe 1 1=Probe 2 2=Digital input 1 3=Digital input 2 4=Set point 1 5=Set point 2 6=Probe 1/Probe 2 alternating 7=Output NO1 status 8=Output NO2 status 9=Output NO3 status 10=Output NO4 status 11=Output Y1 percentage 12=Output Y2 percentage 13=Probe 3 14=Control probe	Control probe

On the bottom row, however, when the unit is switched off, "OFF" will be displayed, while when the unit is switched on, the status of the four regulation digital outputs will be shown, with a progressive number from left to right to indicate the digital outputs are activated/deactivated.

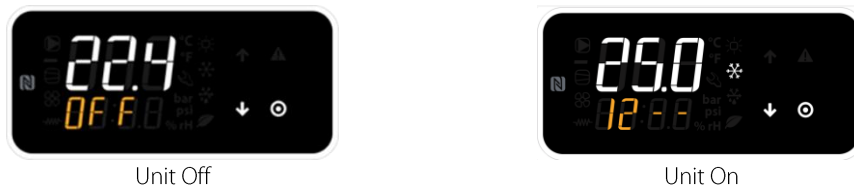

ⓘ Notice: "bLE" flashes on the display during "Bluetooth" communication.

3.3.1 Main unit values

From the main menu, the main controller operating values and unit status can be displayed:

Code	Description
	Unit operating status
On ----	0=Waiting
Unit on	1=Unit ON
OFF ALrM	2=OFF from alarm
	3=Reserved
OFF bMS	4=OFF from BMS
OFF Schd	5=OFF from scheduler
OFF dI	6=OFF from DI
OFF diSP	7=OFF from display
	Season
SEaS	0=Summer
	1=Winter
rEGt	Control probe reading
rSt1	Control set point 1
rSt2	Control set point 2
Prb1	Probe 1 reading
Prb2	Probe 2 reading
Prb3	Probe 3 reading
din1	Digital input 1 reading
din2	Digital input 2 reading
	Relay status
	Relay 1
do	Relay 2
	Relay 3
	Relay 4
dou5	Relay 5 status
Y1	Analogue output 1 %
Y2	Analogue output 2 %
000 000h	Unit operating hours
000 000h1	Output 1 operating hours
000 000h2	Output 2 operating hours
000 000h3	Output 3 operating hours
000 000h4	Output 4 operating hours
rEL	Firmware version
dAY	Day
Mont	Month
YEAr	Year
	Day of the week
	0=Sunday
	1=Monday
UdAY	2=Tuesday
	3=Wednesday
	4=Thursday
	5=Friday
	6=Saturday
Hour	Hours
Min	Minutes

The following procedure shows how to access the main unit values category:



1. Display the main regulation page. A value or status will be shown, as set for parameter B020.



2. Press DOWN to access the main unit values display. The current unit status will be shown first, in the example the status is "Off from Display".



3. Press UP and DOWN to scroll through the read-only parameters in the menu. Note that, compared to the first view, the other read-only parameters are displayed with the bottom row showing the parameter code, while the top row shows the current value.



4. Select ESC and press PRG to return to the main page.

3.3.2 Direct access parameters

From the user terminal it is possible to access the basic configuration parameters and the main commands without entering a password, or, on entering a password, the unit configuration and optimisation parameters.

Below is the list of parameters accessible without entering a password:

Code	Description	Default
UnSt	Set unit on/off from keypad	Off
St1	Set point 1	20.0
St2	Set point 2	40.0
St1E	Set point 1 in economy mode	15.0
St2E	Set point 2 in economy mode	35.0
SEa1	Circuit 1 season	Summer
SEa2	Circuit 2 season	Summer

The procedure described below describes how to access the direct access parameter category and enter programming mode:

 <p>1. Display the main regulation page. A value or status will be shown, as set for parameter B020.</p>	 <p>2. Press PRG for less than 3 s and then release it to access the direct access parameter display. Note that in the parameter list view, the bottom row shows the parameter code, while the top row shows the current value. In the example, parameter UnSt is set to OFF.</p>	 <p>3. Press UP and DOWN to scroll through the menu parameters, press PRG to enter parameter setting mode, as indicated by the value flashing.</p>
 <p>3. Use UP and DOWN to change the value. Press PRG to confirm the displayed value.</p>	 <p>4. On exiting parameter setting mode, use UP and DOWN again to scroll through the menu parameters, as described in point 3.</p>	 <p>5. Some parameters are only displayed if the related regulation function or configuration has been enabled. In the example, parameter St1E (Economy set point 1) is only shown if the scheduler is enabled via parameter Hb00.</p>
 <p>6. Select ESC and press PRG to return to the main page.</p>		

ⓘ Notice: The direct access parameters are automatically saved when exiting parameter setting mode.

3.3.3 Access the programming menu

To prevent accidental changes to the main controller configuration parameters, the programming menu can only be accessed on entering a password.

The login procedure is as follows:

 <p>1. Go to the main regulation page and press and hold PRG for more than 3 seconds. When releasing the button, the password entry prompt (PSd) will be shown.</p>	 <p>2. Press PRG: the first digit of the password will start flashing to indicate that it can be changed using the UP and DOWN buttons.</p>	 <p>3. Set the value and press PRG to confirm. Now the second digit will start flashing. Repeat for each digit to enter the required password.</p>
 <p>4. The last time PRG is pressed, the four digits will be verified and if the password entered is correct, the scrollable programming menu will be shown.</p>	 <p>5. Press UP and DOWN to scroll through the programming menus, press PRG button to access the parameters in the selected menu.</p>	 <p>6. Press UP and DOWN to scroll through the menu parameters, press PRG to enter parameter setting mode, as indicated by the value flashing.</p>
 <p>7. In programming mode, to change the value press UP and DOWN, while to confirm press PRG; the value will stop flashing.</p>	 <p>8. From the parameter, press ESC and PRG to return to the menu. In the menu, press ESC to return to the main regulation page.</p>	

- 📌 Notice:
- Default User password: 0000.
 - Default Service password: 1234.
 - Default Manufacturer password: 5678.
 - The passwords can only be changed from Applica Mobile and Applica Desktop.
 - The Service password also provides access to the user parameters;
 - The Manufacturer password provides access to all the parameters.

3.3.4 Programming menu

Once having accessed the programming menu, select one of the following menus to access the parameter list for a specific category (see paragraph 6 for further details on the parameters):

<p>Category IO / Conf (Input/Output)</p>	<p>Category Ctr / Conf (Control configuration)</p>	<p>Category ALM / Conf (Alarms)</p>
<p>Identified by code loxx, these parameters relate to the configuration of the regulation inputs and outputs.</p>	<p>Identified by code Bxxx, these parameters relate to the controller configuration. They also include PID parameters and special parameters.</p>	<p>Identified by code Cxxx, these parameters relate to the alarm configuration.</p>
<p>Category CLc / Menu (Clock)</p>	<p>Category Sch / Menu (Scheduler)</p>	<p>Category Hst / Menu (Alarm log)</p>
<p>These include the date and time setting parameters.</p>	<p>Identified by code Hbxx, these parameters are used for setting and managing the time bands, special days and vacation periods.</p>	<p>Access to the alarm log. Each event is described alternately by an alarm code and the time (in hh:mm format).</p>
<p>Category StG / Menu (Settings)</p>	<p>Log Out</p>	<p>ESC</p>
<p>Identified by code Hdxx, these parameters relate to the network and hardware settings.</p>	<p>Log Out command to exit the main menu and log out the user.</p>	<p>Press ESC and then PRG to exit the programming menu.</p>

📌 Notes

- If no button is pressed, after approximately 1 minute (time set by parameter Hd99), the terminal automatically returns to display the main page.
- The parameters are automatically saved when exiting parameter programming mode.
- When initialising via parameter rStr (either from the display or from Applica), wait until the application has completed the automatic restart, as indicated by the current firmware version shown on the display.
- Initialisation via parameter rStr is recommended before changing operating mode (parameter B000).

4. COMMISSIONING

The Universal Controller user terminal contains a subset of the available regulation and configuration parameters (see paragraph 6). Consequently, the user terminal cannot be used to configure the Universal Controller.

This is done using Applica, an application that is available in two formats:

1. Applica mobile (see paragraph 4.1 Applica app)
2. Applica desktop (see paragraph 4.3 Applica Desktop)

Applica can connect to the Universal Controller and access the complete list of configuration parameters.

4.1 Applica app

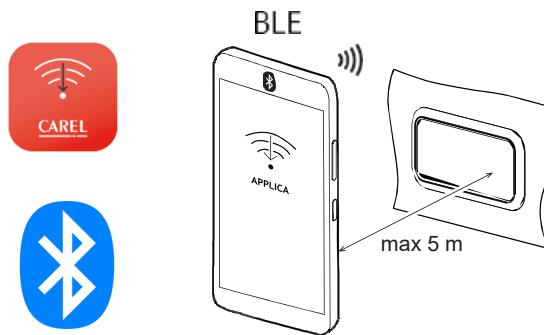

The “Applica” app can be used to configure the controller from a mobile device (smartphone, tablet), via Bluetooth (BLE). Users can both configure the commissioning parameters and set groups of parameters according to specific needs (configurations).

4.1.1 Connection to the controller

Below is the connection procedure to be followed once the Carel “Applica” app has been installed and is running:

1. Select Bluetooth
2. The controllers available for connection will be listed. Select the desired controller
3. Accept the pairing request between the smartphone/tablet and the controller

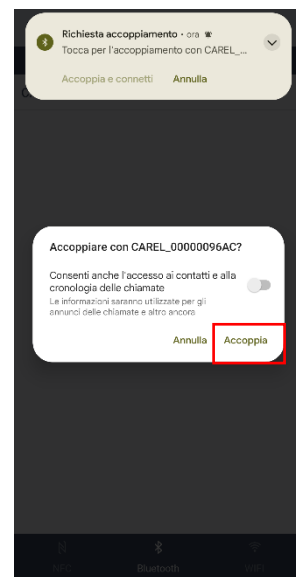
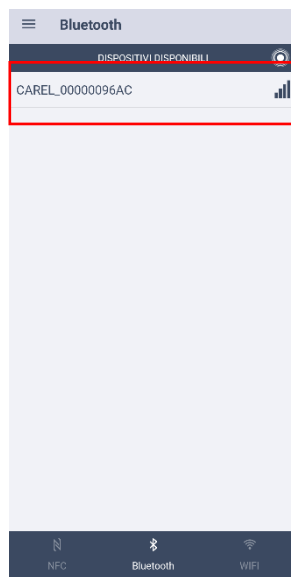
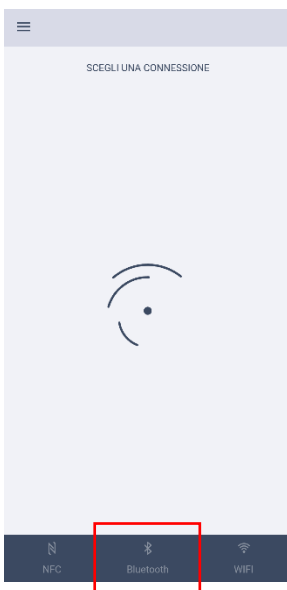

4. A pop-up message will be shown to choose the access profile

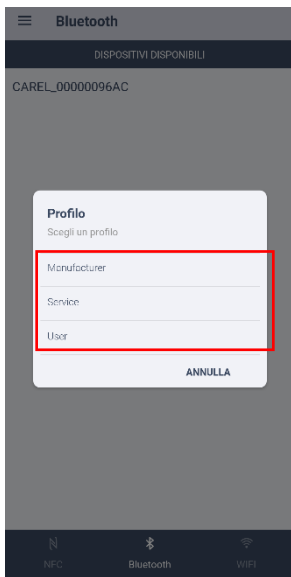

5. Enter the password for the chosen profile (see paragraph 3.3.3) and select OK

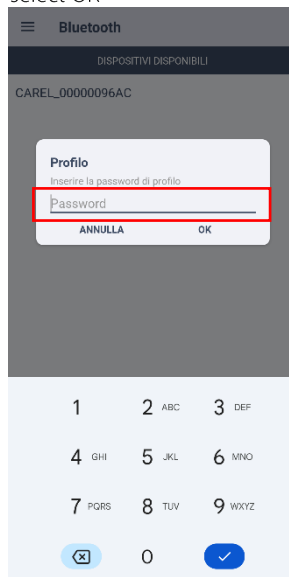

6. The app home page will be shown



4.2 Configuration procedure

4.2.1 Main sections

The mobile app main screen shows the following information:

1. Values measured by the probes
 - Probe 1
 - Probe 2 (if configured)
 - Probe 3 (if configured)
2. Operating status
 - Unit status
 - Season (if configured)
 - Time bands (if configured)
3. Values measured by the digital inputs (if configured)
4. Commands sent to analogue and digital outputs

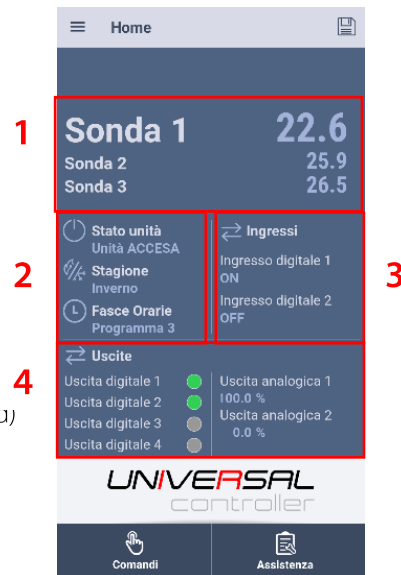

The "Commands" section contains the main unit commands and settings, such as On/Off, circuit heat/cool mode setting and the various set points:

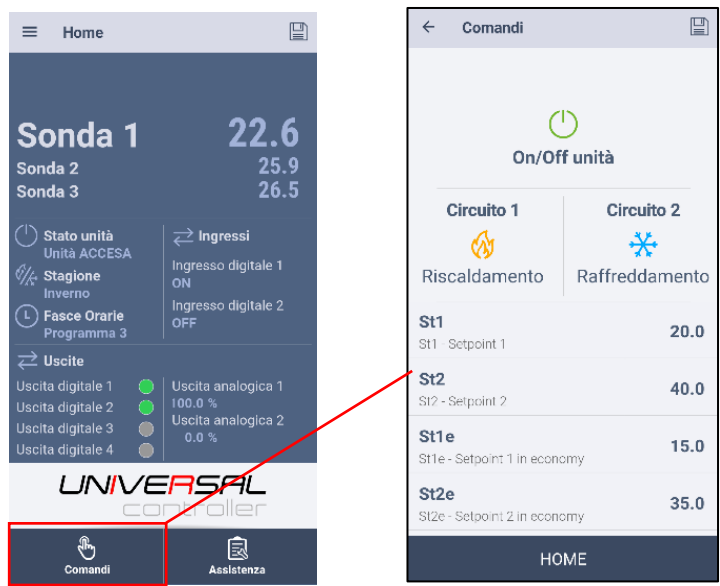

Tapping the "Service" button accesses the configuration parameter settings menu, divided based on the category (regulation, scheduler, IO configuration and alarm configuration), as well as the complete list of read-only values (Information).

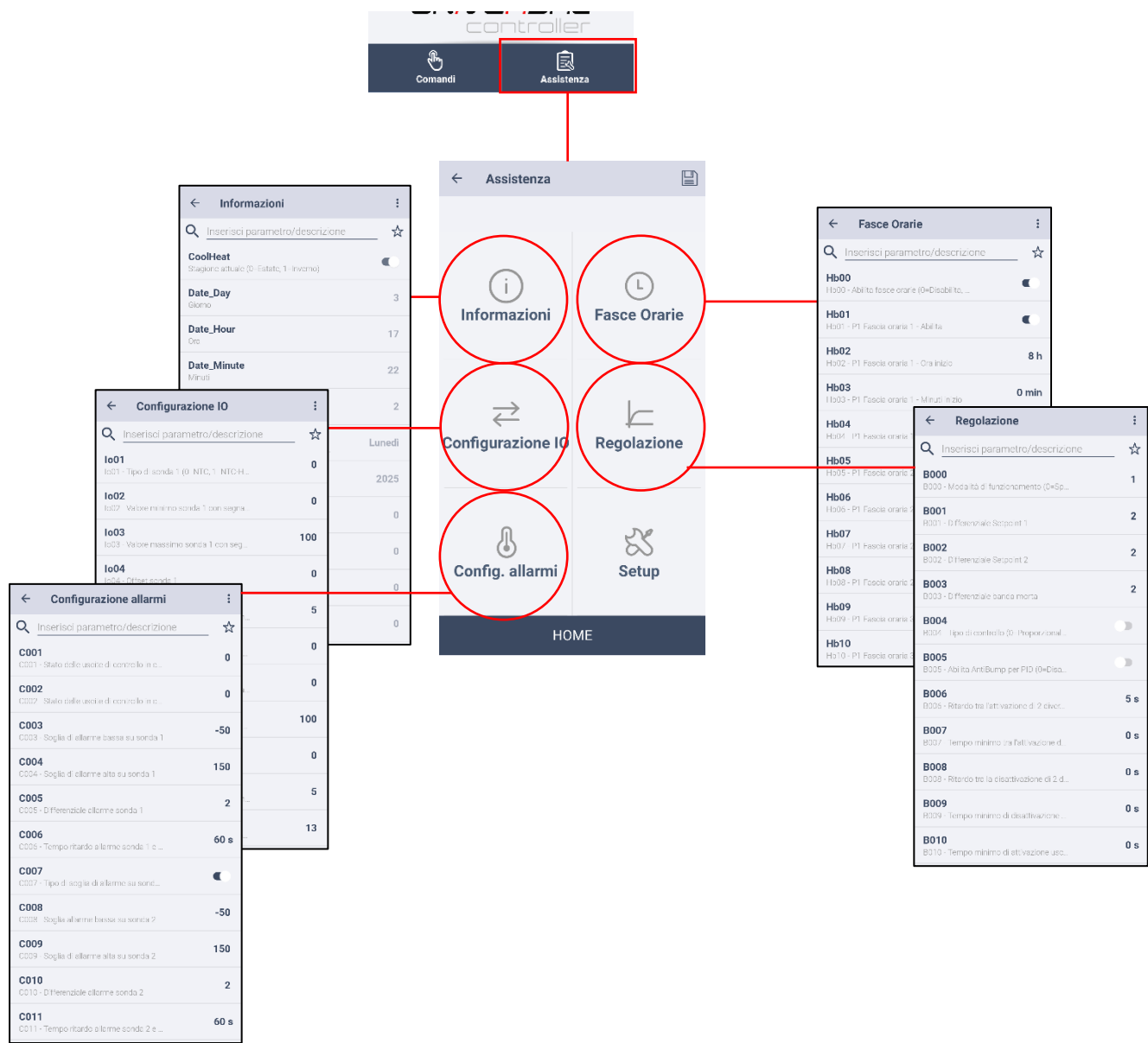

The "Setup" section contains the settings needed to configure the controller, such as the parameter list, unit configurations, communication and network parameters, change ID and upgrade FW:

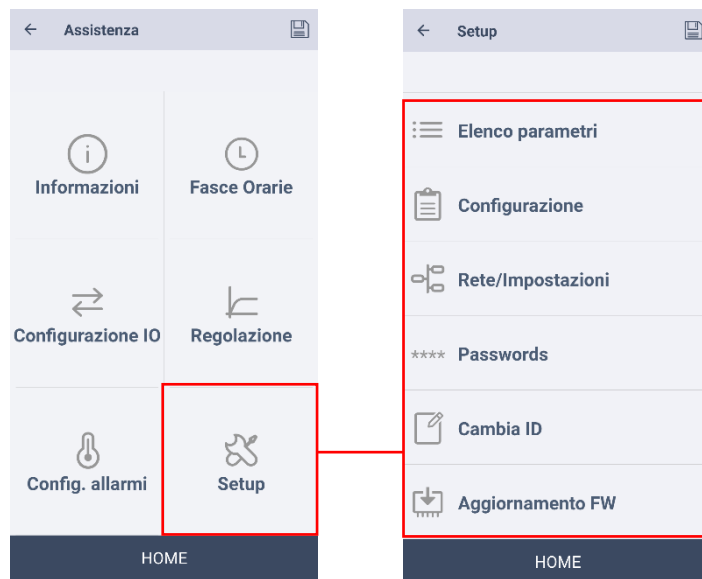

The side menu, accessible from the home page, contains shortcuts to access the main settings and information, such as the parameter list, alarm management, and configurations:

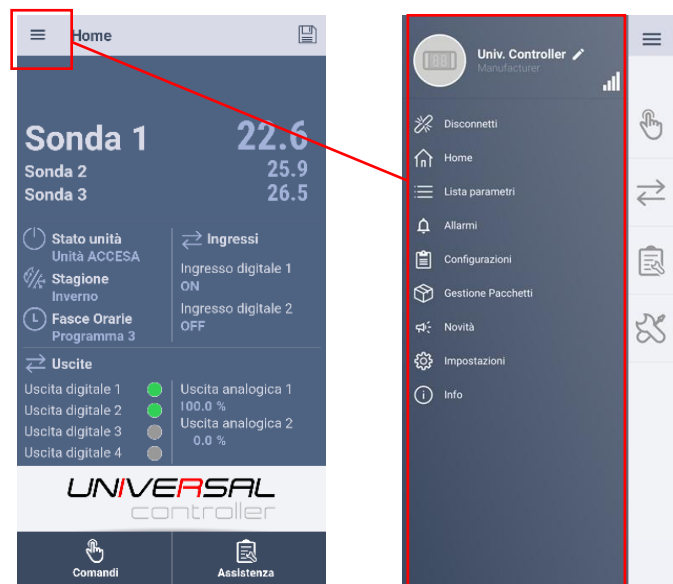

4.2.2 Parameter list

The parameter list shows all the parameters that can be read and set by the user.

For simpler navigation, the Applica app features filters to group the parameters by type and category.

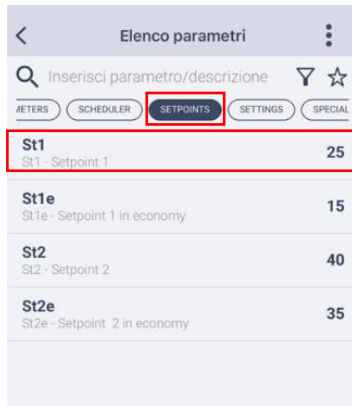

To apply a filter, simply tap the funnel icon at the top right and select one or more categories.

Alternatively, scroll through the horizontal list in the basic view and tap the individual category.

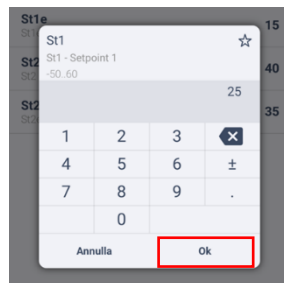

To set the value of a parameter, click the parameter, enter the desired value and tap "Ok" to confirm.

The value will be updated, and an asterisk (*) will be shown alongside while the value is being written to the controller.



4.2.3 Create a unit configuration

Applica includes a "Save Configuration" feature, used to create custom unit configurations.

The saved configurations include all the parameters that can be customised by the user; these can also be used on multiple controllers, for rapid custom configuration of multiple units.

Proceed as follows:

1. At the top right of each menu there is an icon representing the "Save configuration" function.



2. Tap the icon and assign a name to the configuration, then tap "Ok" to save



To apply a previously saved configuration, proceed as follows:

1. Go to the Service menu and tap Setup



2. Tap the Configuration item

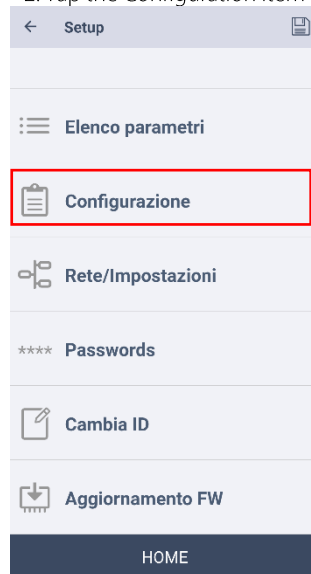

3. Choose the desired configuration

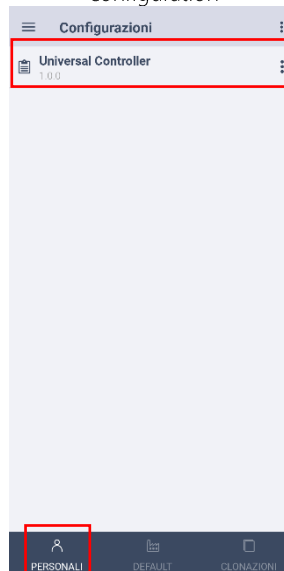

4. Apply the configuration

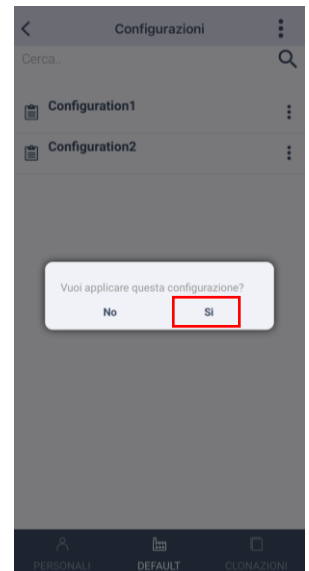

Alternatively, the configurations can also be applied using the following procedure:

1. Open the side menu and tap Settings

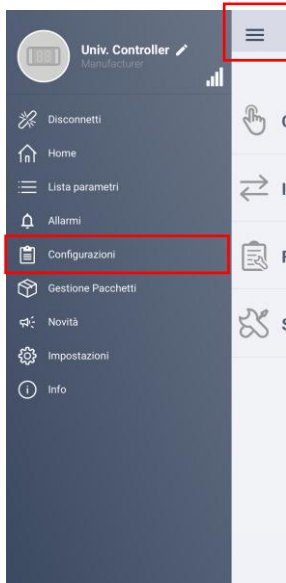

2. Choose a configuration

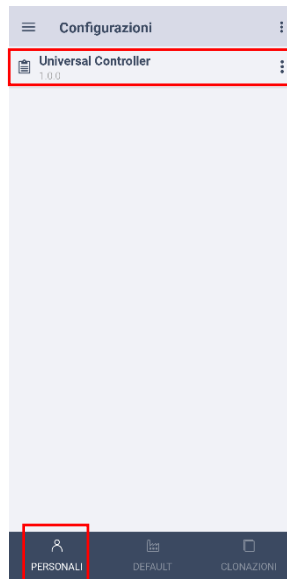

3. Apply the configuration

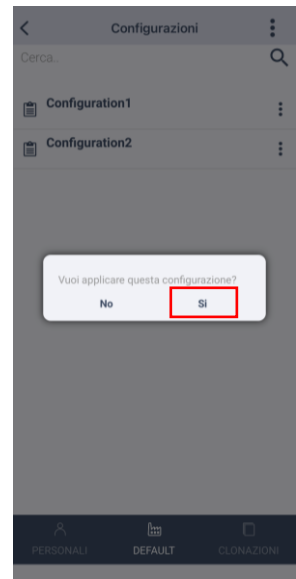

4.2.4 FW update

In the Applica app, the controller firmware can be updated from the "Setup" menu.

Proceed as follows:

1. Go to the Setup menu and tap the "Update FW" item. Tap "OK"



2. The smartphone file manager app will open.
Select the desired .pack file



3. Applica will show information on the selected .pack.
After confirming by tapping "Ok", the firmware will be installed

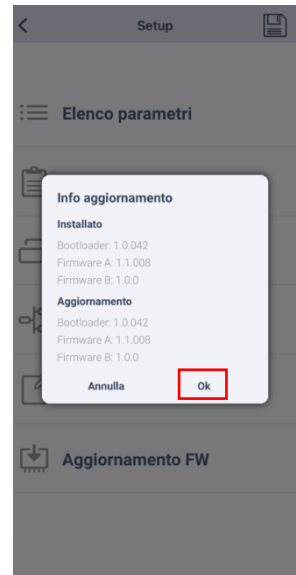

At the end of the procedure, the controller will reboot to apply the new firmware. Connect to the controller again via Bluetooth.

4.3 Applica Desktop

Applica Desktop is a program intended for manufacturers and installers of units equipped with the Universal Controller. It can be downloaded from ksa.carel.com.

Applica Desktop offers the possibility to:

- access the controller using the assigned profile;
- create configurations;
- apply configurations;
- clone a unit configuration, i.e. copy all of the unit's parameter values;
- complete the commissioning procedure;
- troubleshoot any problems on the unit.

Notice:

Applica Desktop can be used as an alternative to the Applica app, and requires an internet connection; For the physical connection to the Universal Controller's BMS port, use the USB/RS485 converter P/N CVSTDUMORO.

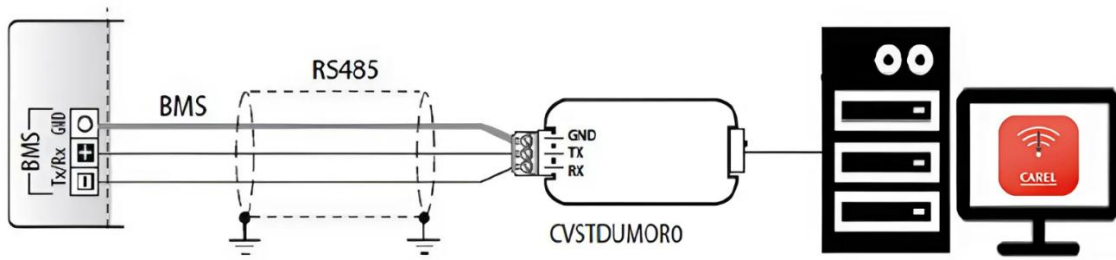

4.3.1 Connection to the controller

1. Connect to the Universal Controller's BMS port using the USB/RS485 converter P/N CVSTDUMORO;
2. Open Applica Desktop; a window will open with the top bar of the work area as shown in the figure:



3. Select "Add Target" and assign it a meaningful name (e.g. "Universal Controller");
4. In the "COM Port" field, enter the COM port used for the USB connection to the USB/RS485 converter.
5. Configure the connection parameters as shown in the figure (the data are saved automatically);
6. Click "Connect" to connect to the Universal Controller (this must already be powered on);

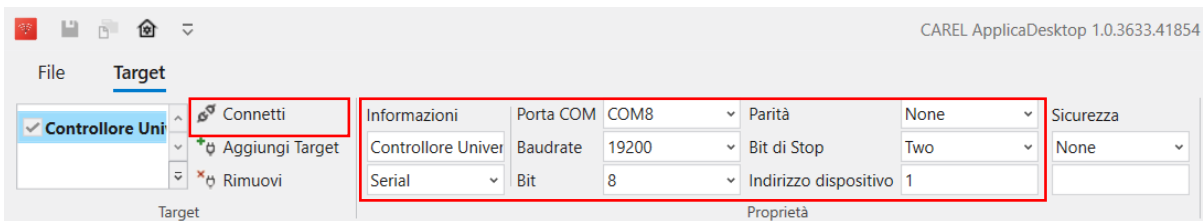

7. To complete the connection to the controller, choose the desired access level and enter the corresponding password (see paragraph 3.3.3).

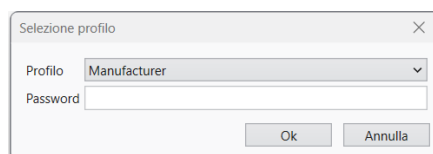

4.4 Setup procedure with Applica Desktop

4.4.1 Create a unit configuration

1. Select the "Configurations" section, click the "New" icon and then "New Configuration".

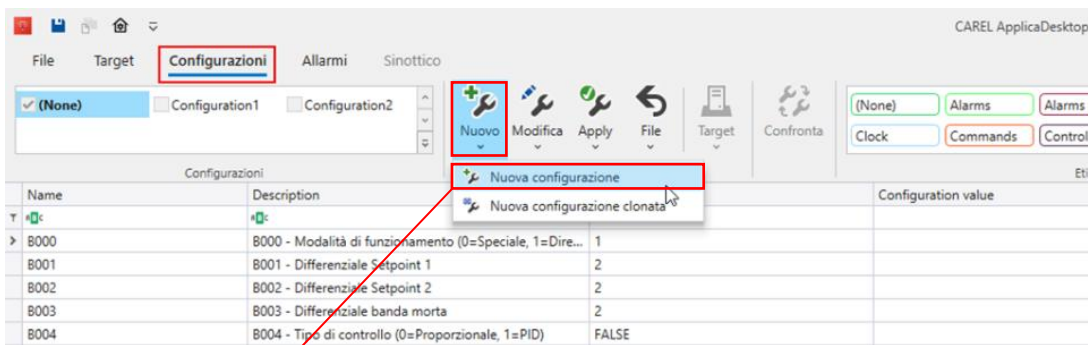

A

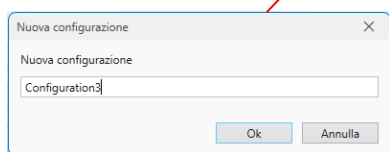

new window will open with a prompt to enter a name for the new configuration being created.

2. Select the new configuration, then "Edit -> Apply real values". This operation copies the values of the parameters currently saved on the connected Universal Controller to the newly created configuration.

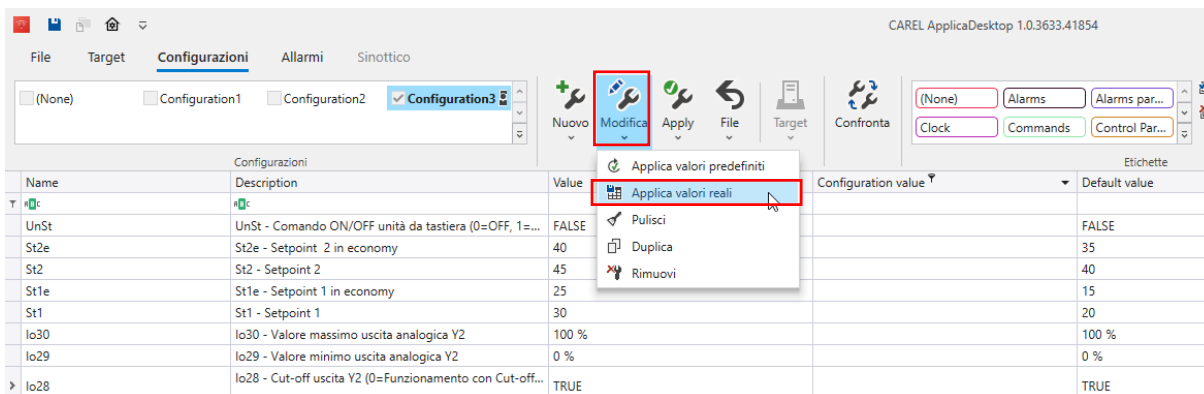

The configuration values are listed in the "Configuration value" column, while the "Default value" column shows the default values of the parameters defined by the application.

Only the values in the first column can be set, so as to customise the currently selected configuration.

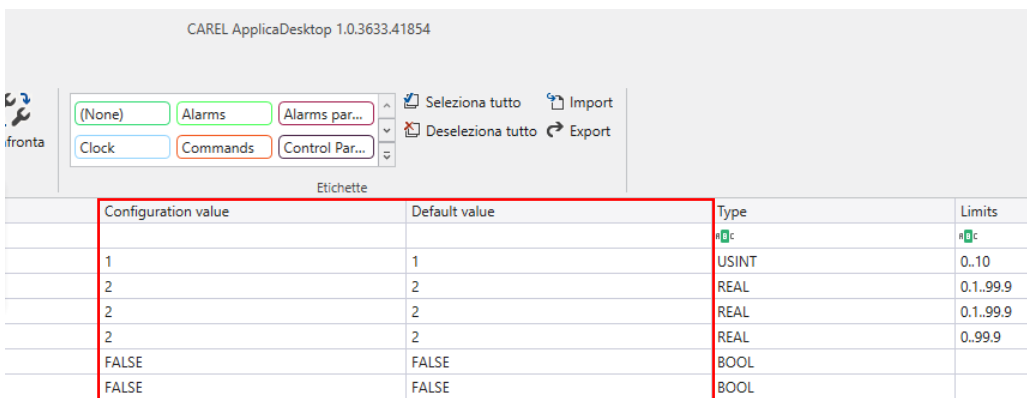

- From the top section containing the Tags, select IO configuration to set the input and output configuration parameters.

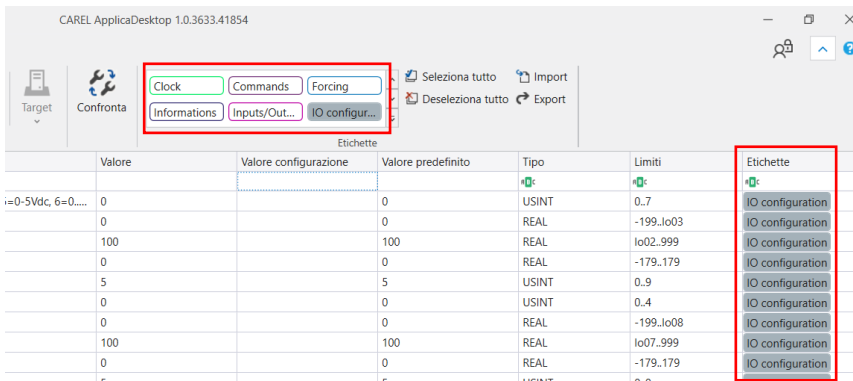

- Set the parameters listed in the "Configuration value" column to configure the unit.
 - Repeat steps 3 and 4 for the "Control" and "Main parameters" tags.
 - The unit has now been configured. If desired, the regulation parameters can be set using the other available tags as a search filter.
 - To apply the new configuration to the controller, select one of the created configurations, then click the Applica icon and then Apply configuration.
- The values of the configuration parameters (shown in the "Configuration value" column) have now been applied.

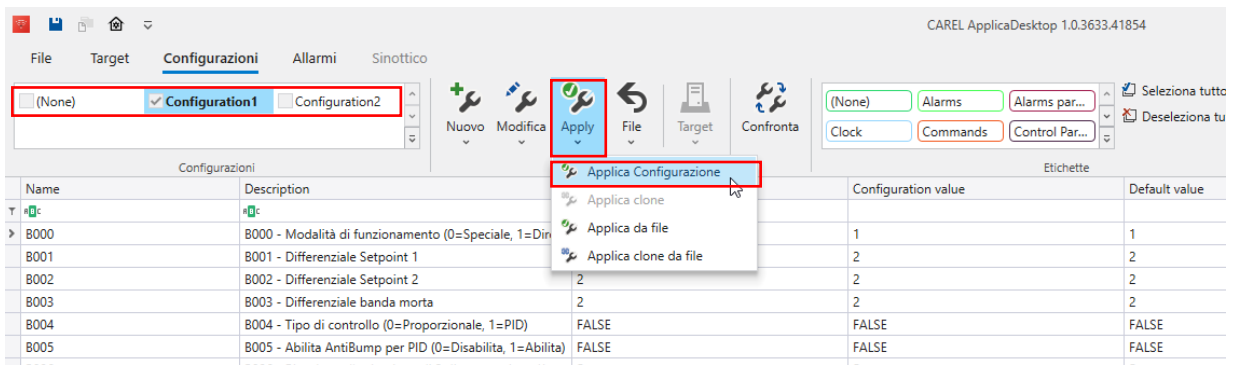

Finally, to save the newly-created configuration for future use, from the "Configurations" section select "File -> Export" and assign a name to the configuration being saved.

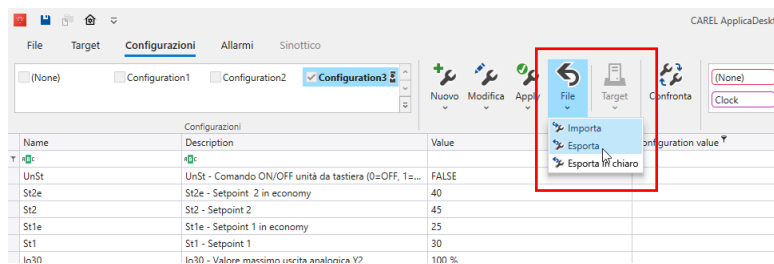

4.4.2 Date and time setting

Applica Desktop has a function for aligning the controller's date and time with the values set on the connected PC.

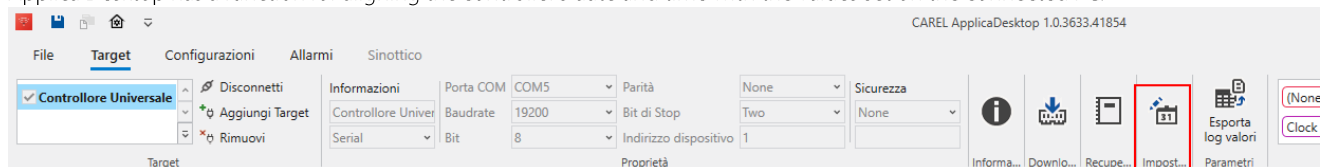

Once having connected to the controller, click "Set date/time" and then confirm in the pop-up that will be displayed.

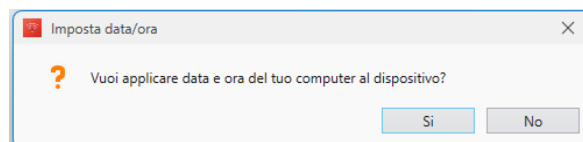

4.4.3 Parameter list

The list of parameters and variables is shown in the “Target” section. To simplify parameter searching and management, Applica Desktop features filters that group parameters by type and category.

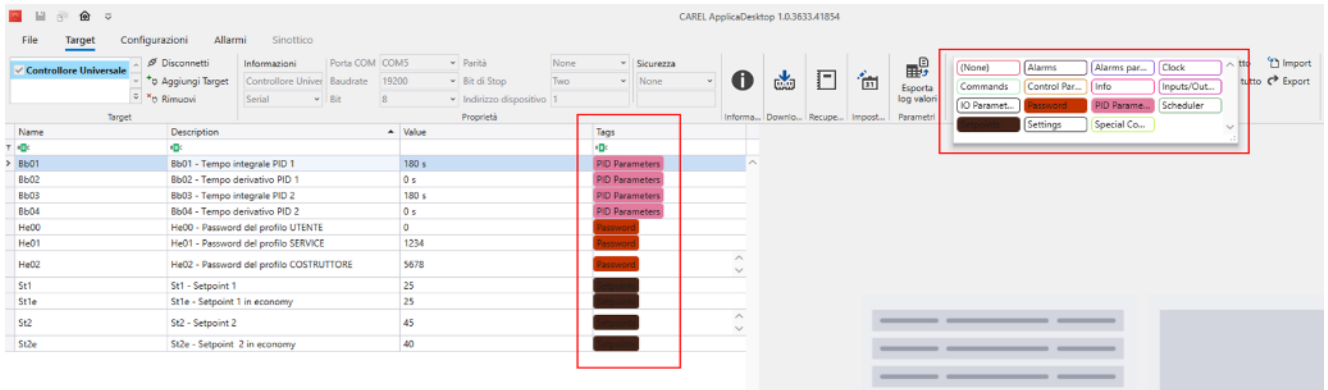

To apply a filter, simply select one or more desired categories from the list at the top right or alternatively move the mouse pointer to the beginning of the column (in this case Tags, however the same applies to all the other columns) and click the funnel icon to select the values to be filtered or apply a rule.

To set the parameter value, click it in the “Value” column and enter the new value.

4.4.4 FW update

In Applica Desktop, the controller firmware can be updated from the “Target” section.

To start the update click “Download” and select the desired .pack file in file explorer:

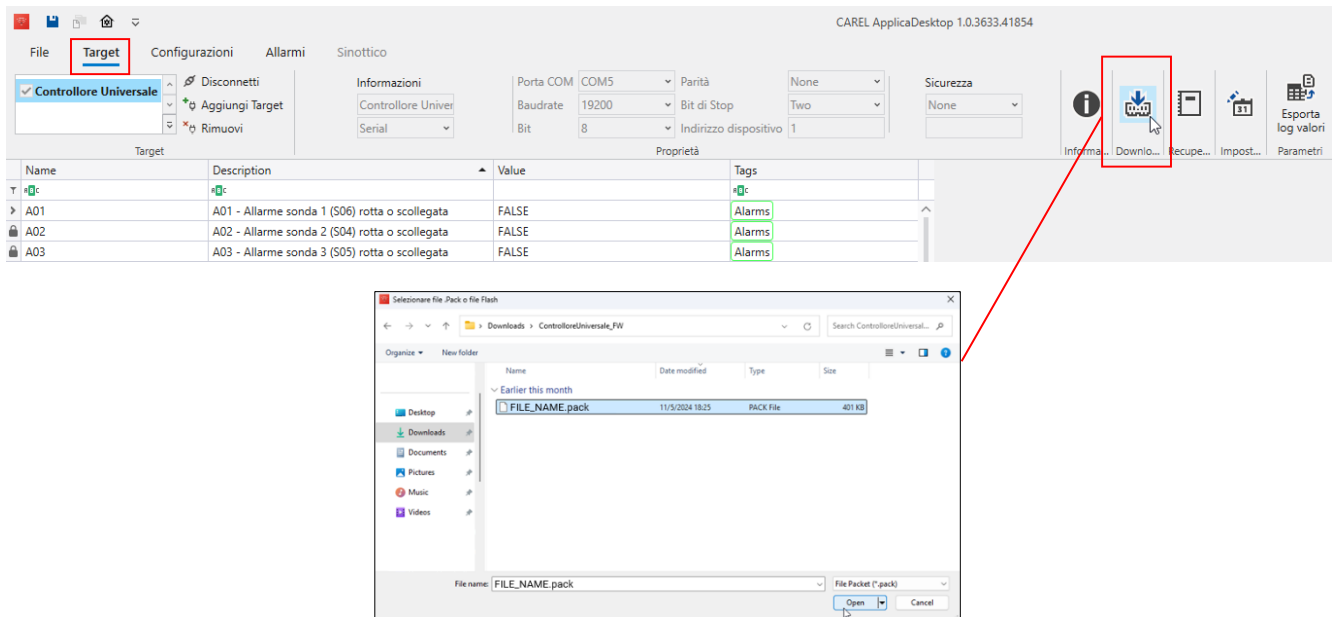

At the end of the procedure, the controller will reboot to apply the new firmware.