

# FE2owlet

for single phase alternating current, 4 pole

FN050-4E

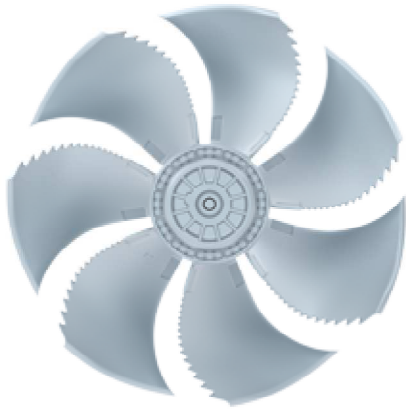

### Description

Motor technology: AC  
 Rated voltage  $U_N$ : 1~ 230 V±10 %\*  
 Rated frequency  $f_N$ : 50 Hz\* (60Hz data available)  
 Input power  $P_i$ : 0.72 kW\*  
 Rated current  $I_N$ : 3.20 A\*  
 Rated speed  $n_N$ : 1240 min<sup>-1</sup>\*  
 Starting current  $I_s$ : 6.50 A  
 Current increase  $\Delta I$ : 0 %  
 Service capacitor  $C_{400V}$ : 16.0 µF  
 Thermal class: THCL155\*  
 Min. permitted ambient temperature  $t_{R(min)}$ : -25 °C  
 Max. permitted ambient temperature  $t_{R(max)}$ : 70 °C  
 Electrical connection: Terminal box  
 Number of blades: 7  
 Protection class: IP54  
 Motor protection: thermal contact  
 Blades: Aluminium, uncoated  
 Rotor: Aluminium, uncoated  
 Conformity: ErP 2015, CE  
**ErP-data**  
 Efficiency  $\eta_{statA}$ : 32.9 %  
 Efficiency:  $N_{actual} = 40.3 / N_{target} = 40$ \*\*  
 \* Rated data  
 \*\*ErP 2015

### Characteristic curve

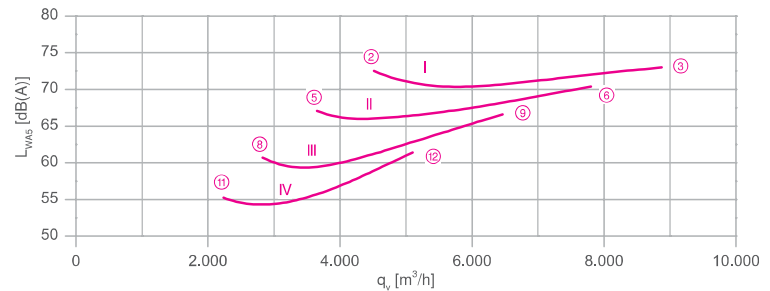
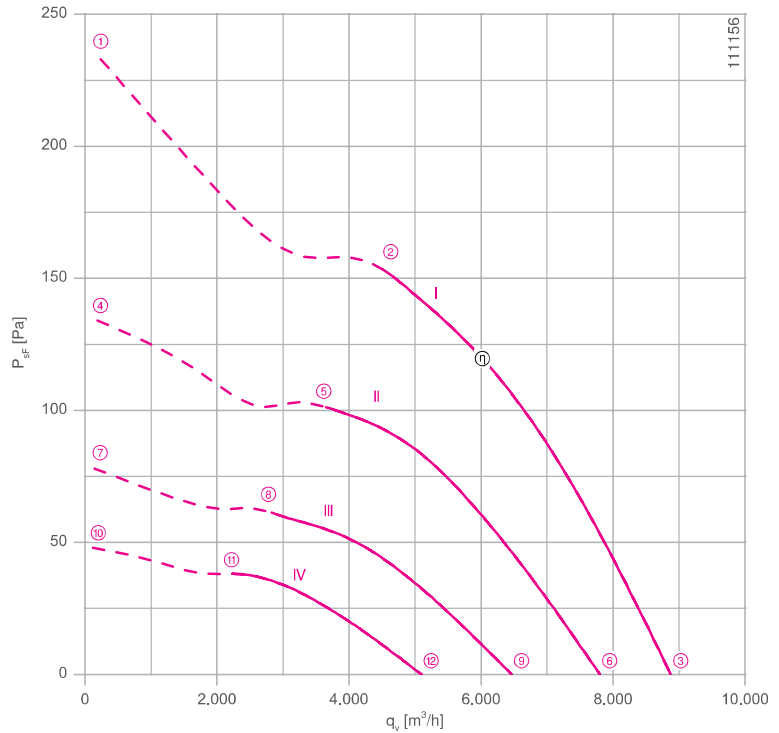

Measured in full bell mouth without guard grille in installation type A according to ISO 5801

Connection diagram Page 531  
 for airflow direction A 1360-104XB  
 for airflow direction V 1360-104XA

System components Page 430

### Dimensions mm

#### Airflow direction A

Design W - axial bolted, mounting for short bell mouth, guard grille suction side

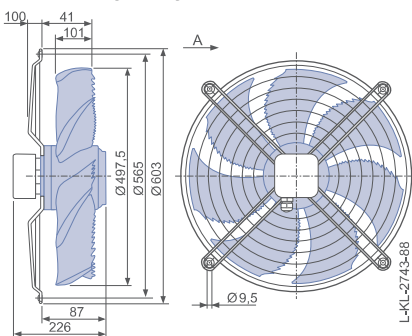

Design Q - square full bell mouth, guard grille suction side

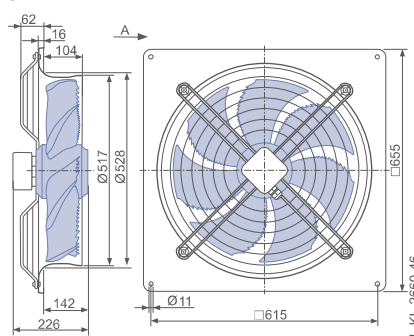

#### Airflow direction V

Design K - axial bolted, mounted for short bell mouth, guard grille pressure side

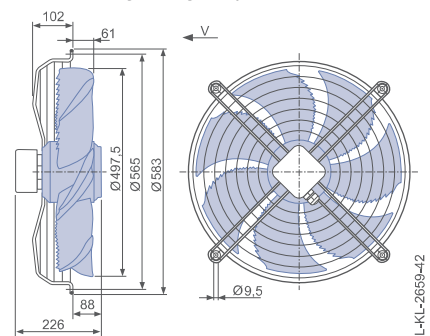





Performance data

Type	Characteristic curve	Voltage	Operating point	Current	Input power	Speed	Suction side sound power level $L_{WA5}$ dB(A)
		U V		I A	$P_1$ W	n min <sup>-1</sup>	
FN050-4E_4I_7	I	230	①	3.70	840	1150	
		230*	②	3.20*	720*	1240*	73
		230	③	2.60	600	1320	73
	II	170	④	3.50	580	880	
		170	⑤	3.20	520	1010	67
		170	⑥	2.70	460	1160	70
	III	135	⑦	3.10	390	660	
		135	⑧	2.90	380	780	61
		135	⑨	2.60	350	960	67
	IV	110	⑩	2.60	270	520	
		110	⑪	2.60	270	620	55
		110	⑫	2.40	260	760	61

\*rated data

Fan ordering information

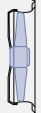
Design	Airflow direction A			Airflow direction V		
	W (guard grille suction side)	Q (guard grille suction side)	K (guard grille pressure side)	F (without guard grille)	F (guard grille pressure side)	Q (guard grille pressure side)
						
Type	FN050-4EW.4I.A7P1	FN050-4EQ.4I.A7P1	FN050-4EK.4I.V7P1	FN050-4EF.4I.V7P1	FN050-4EF.4I.V7P1	FN050-4EQ.4I.V7P1
Article no.	167953	167952	167956	167957	167958	167955
Weight kg	13.80	20.10	13.30	16.80	17.50	18.30

Control technology

<p>Frequency inverters Fcontrol 1~</p>  <p>Page 474</p>	<p>Motor protection units 1~</p>  <p>Page 518</p>	<p>Electronic voltage controllers 1~</p>  <p>Page 492</p>
--	--	--

Design F - flange ring with two flanges, without guard grille

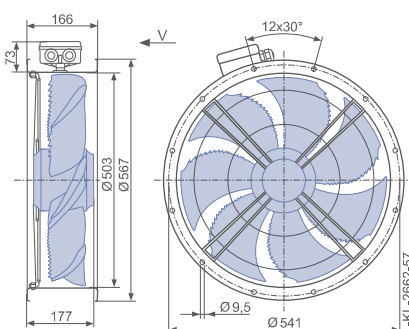

Design F - flange ring with two flanges, guard grille pressure side

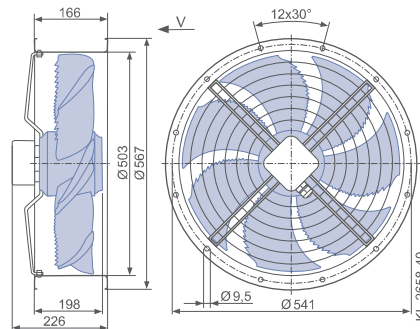

Design Q - square full bell mouth, guard grille pressure side

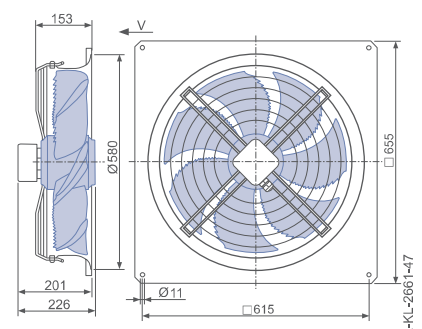

# FE2owlet

for single phase alternating current, 6 pole

FN050-6E

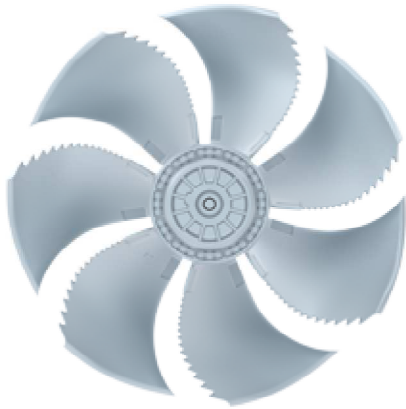

## Description

Motor technology: AC  
 Rated voltage  $U_N$ : 1~ 230 V±10 %\*  
 Rated frequency  $f_N$ : 50 Hz\* (60Hz data available)  
 Input power  $P_i$ : 270 W\*  
 Rated current  $I_N$ : 1.25 A\*  
 Rated speed  $n_N$ : 900 min<sup>-1</sup>\*  
 Starting current  $I_s$ : 2.60 A  
 Current increase  $\Delta I$ : 15 %  
 Service capacitor  $C_{400V}$ : 5.0  $\mu$ F  
 Thermal class: **THCL155**\*  
 Min. permitted ambient temperature  $t_{R(min)}$ : -25 °C  
 Max. permitted ambient temperature  $t_{R(max)}$ : 70 °C  
 Electrical connection: Terminal box  
 Number of blades: 7  
 Protection class: IP54  
 Motor protection: thermal contact  
 Blades: Aluminium, uncoated  
 Rotor: Aluminium, uncoated  
 Conformity: ErP 2015, CE  
**ErP-data**  
 Efficiency  $\eta_{statA}$ : 30.4 %  
 Efficiency:  $N_{actual} = 40.6 / N_{target} = 40$ \*\*  
 \* Rated data  
 \*\*ErP 2015

## Characteristic curve

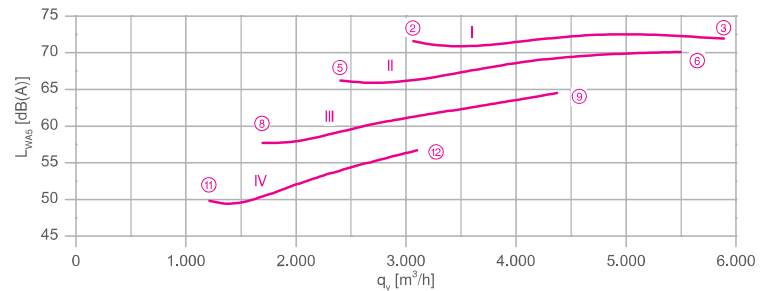
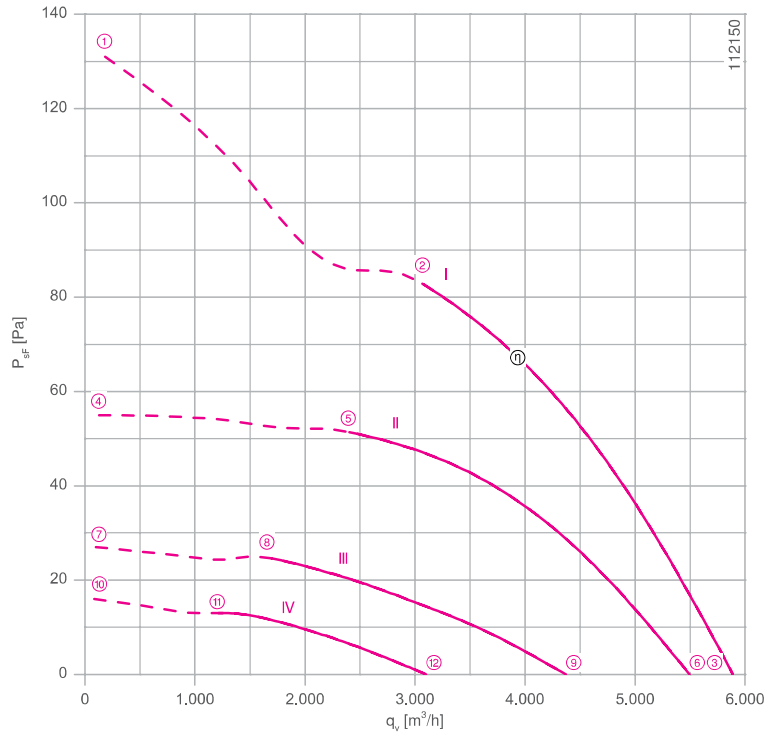

Measured in full bell mouth without guard grille in installation type A according to ISO 5801

Connection diagram Page 531  
 for airflow direction A 1360-104XB  
 for airflow direction V 1360-104XA

System components Page 430

## Dimensions mm

### Airflow direction A

Design W - axial bolted, mounting for short bell mouth, guard grille suction side

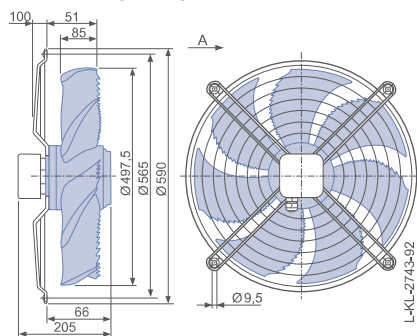

Design W - axial bolted, mounting for short bell mouth, guard grille suction side

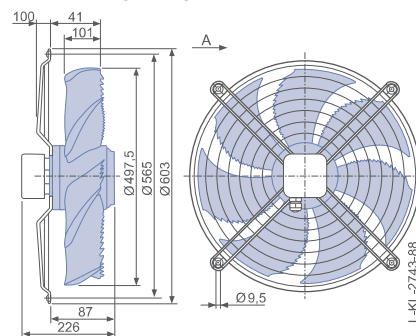

Design Q - square full bell mouth, guard grille suction side

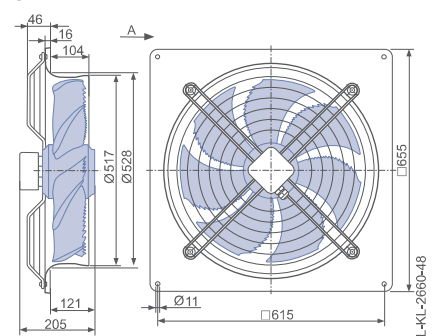

Performance data

Type	Characteristic curve	Voltage	Operating point	Current	Input power	Speed	Suction side sound power level $L_{WA5}$ dB(A)
		U V		I A	$P_1$ W	n min <sup>-1</sup>	
FN050-6E_.4F_.7P3	I	230	①	1.60	340	830	
		<b>230*</b>	②	<b>1.25*</b>	<b>270*</b>	<b>900*</b>	72
		230	③	0.94	200	940	72
	II	170	④	1.60	240	550	
		170	⑤	1.40	210	710	66
		170	⑥	0.98	160	880	70
	III	135	⑦	1.35	150	380	
		135	⑧	1.30	150	490	58
		135	⑨	1.15	140	710	65
	IV	110	⑩	1.10	100	290	
		110	⑪	1.10	100	360	50
		110	⑫	1.05	100	500	57

\*rated data

Fan ordering information

Airflow direction A			Airflow direction V			
Design	W (guard grille suction side)	W (guard grille suction side)	Q (guard grille suction side)	K (guard grille pressure side)	F (without guard grille)	F (guard grille pressure side)
<b>Type Article no.</b>	<b>FN050-6EW.4F.A7P3 167961</b>	<b>FN050-4EW.4I.A7P1 167953</b>	<b>FN050-6EQ.4F.A7P3 167960</b>	<b>FN050-6EK.4F.V7P3 167964</b>	<b>FN050-6EF.4F.V7P3 167965</b>	<b>FN050-6EF.4F.V7P3 167966</b>
Weight kg	11.10	13.80	18.60	10.60	14.10	14.80

Control technology

Frequency inverters Control 1~  Page 474	Motor protection units 1~  Page 518	Electronic voltage controllers 1~  Page 492
---	--	--

Airflow direction V

Design K - axial bolted, mounted for short bell mouth, guard grille pressure side

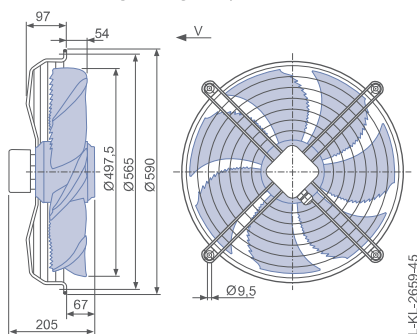

Design F - flange ring with two flanges, without guard grille

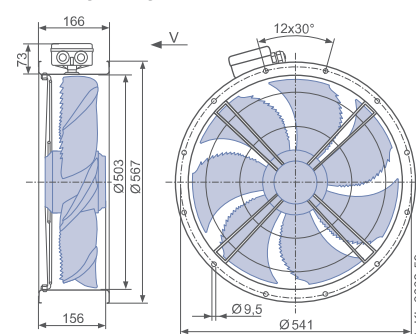

Design F - flange ring with two flanges, guard grille pressure side

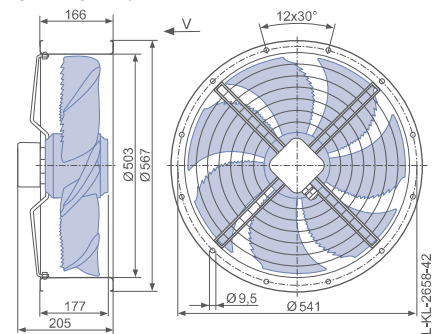

# FE2owlet

for single phase alternating current, 8 pole

FN050-8E

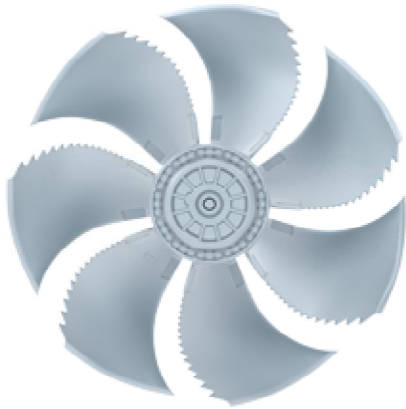

## Description

Motor technology: AC  
 Rated voltage  $U_N$ : 1~ 230 V $\pm$ 10 %\*  
 Rated frequency  $f_N$ : 50 Hz\* (60Hz data available)  
 Input power  $P_i$ : 130 W\*  
 Rated current  $I_N$ : 0.62 A\*  
 Rated speed  $n_N$ : 640 min<sup>-1</sup>\*  
 Starting current  $I_s$ : 1.00 A  
 Current increase  $\Delta I$ : 0 %  
 Service capacitor  $C_{400V}$ : 2.5  $\mu$ F  
 Thermal class: **THCL155\***  
 Min. permitted ambient temperature  $t_{R(min)}$ : -25 °C  
 Max. permitted ambient temperature  $t_{R(max)}$ : 70 °C  
 Electrical connection: Terminal box  
 Number of blades: 7  
 Protection class: IP54  
 Motor protection: thermal contact  
 Blades: Aluminium, uncoated  
 Rotor: Aluminium, uncoated  
 Conformity: CE  
**ErP-data**  
 Not subject to the regulations of ErP directive ( $P_i < 125$  W)  
 \* Rated data

## Characteristic curve

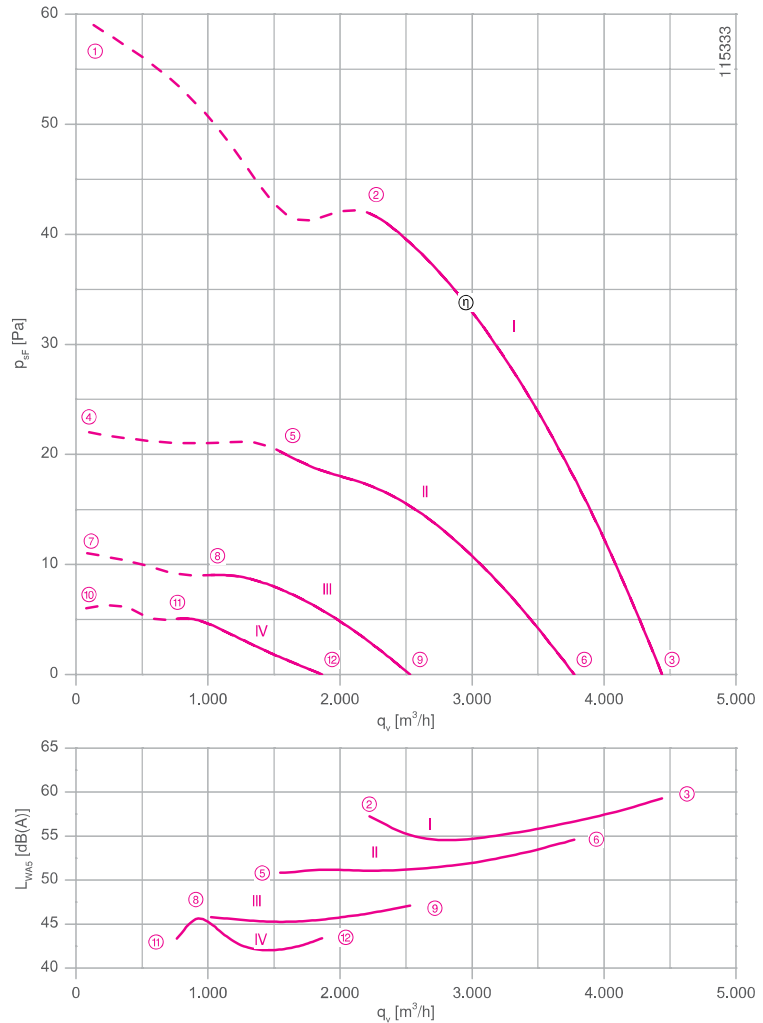

Measured in full bell mouth without guard grille in installation type A according to ISO 5801

Connection diagram Page 531  
 for airflow direction A 1360-104XB  
 for airflow direction V 1360-104XA

System components Page 430

## Dimensions mm

Airflow direction A

Design Q - square full bell mouth, guard grille suction side

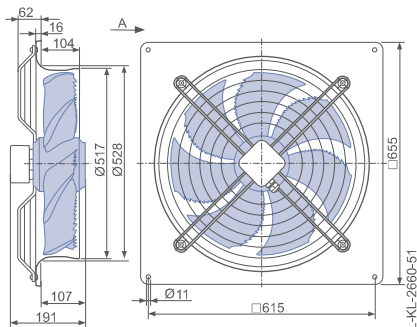

Airflow direction V

Design K - axial bolted, mounted for short bell mouth, guard grille pressure side

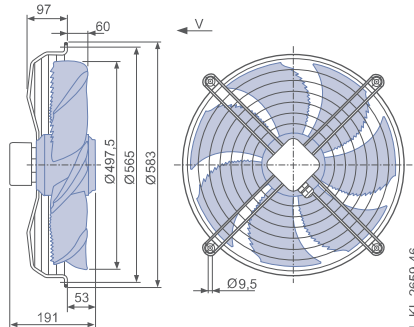

Design F - flange ring with two flanges, without guard grille

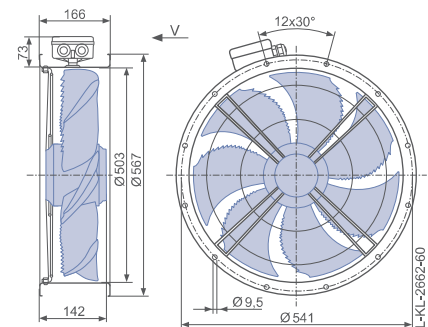

Performance data

Type	Characteristic curve	Voltage	Operating point	Current	Input power	Speed	Suction side sound power level $L_{WA5}$ dB(A)
		U V		I A	$P_1$ W	n min <sup>-1</sup>	
FN050-8E_.4C_.7P1	I	230	①	0.74	150	580	
		230*	②	0.62*	130*	630*	57
		230	③	0.52	110	680	59
	II	170	④	0.66	100	360	
		170	⑤	0.64	95	440	51
		170	⑥	0.54	85	580	55
	III	135	⑦	0.54	65	250	
		135	⑧	0.54	65	300	46
		135	⑨	0.52	60	390	47
	IV	110	⑩	0.46	42	190	
		110	⑪	0.44	42	220	43
		110	⑫	0.44	42	290	43

\*rated data

Fan ordering information

Design	Airflow direction A		Airflow direction V		
	Q (guard grille suction side)	K (guard grille pressure side)	F (without guard grille)	F (guard grille pressure side)	Q (guard grille pressure side)
<b>Type</b>	FN050-8EQ.4C.A7P1	FN050-8EK.4C.V7P1	FN050-8EF.4C.V7P1	FN050-8EF.4C.V7P1	FN050-8EQ.4C.V7P1
<b>Article no.</b>	171237	171233	171235	171232	171234
<b>Weight kg</b>	16.90	10.10	13.60	14.30	14.60

Control technology

Frequency inverters Control 1~ 	Motor protection units 1~ 	Electronic voltage controllers 1~ 
Page 474	Page 518	Page 492

Design F - flange ring with two flanges, guard grille pressure side

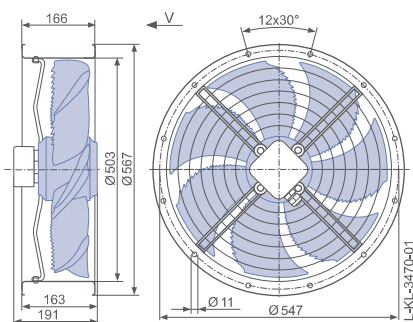

Design Q - square full bell mouth, guard grille pressure side

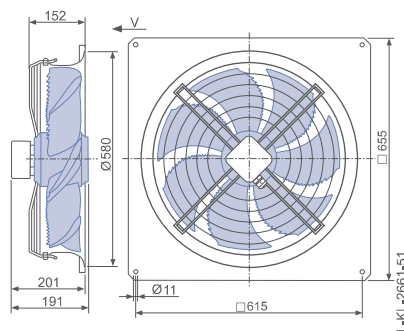

# FE2owlet

for three phase alternating current, 4-4 pole

FN050-VD

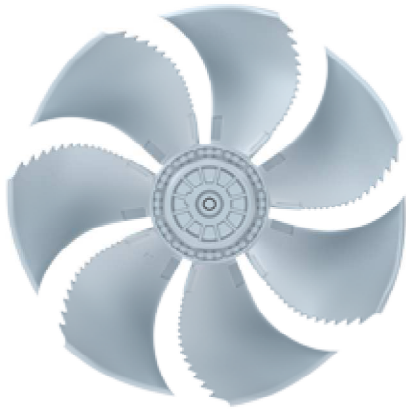

## Description

Motor technology: AC  
 Rated voltage  $U_N$ : 3- 400 V ( $\Delta/Y$ )  $\pm 10\%$ \*  
 Rated frequency  $f_N$ : 50 Hz\*  
 Input power  $P_i$ : 0.84/0.54 kW\*  
 Rated current  $I_N$ : 1.45/0.96 A\*  
 Rated speed  $n_N$ : 1340/ 940 min<sup>-1</sup>\*  
 Starting current  $I_s$ : 5.00 / 1.60 A  
 Current increase  $\Delta I$ : 15 %  
 Thermal class: **THCL155\***  
 Min. permitted ambient temperature  $t_{R(min)}$ : -40 °C  
 Max. permitted ambient temperature  $t_{R(max)}$ : 70 °C  
 Electrical connection: Terminal box  
 Number of blades: 7  
 Protection class: IP54  
 Motor protection: thermal contact  
 Blades: Aluminium, uncoated  
 Rotor: Aluminium, uncoated  
 Conformity: ErP 2015, CE  
**ErP-data**  
 Efficiency  $\eta_{statA}$ : 34.2 %  
 Efficiency:  $N_{actual} = 41.3 / N_{target} = 40^{**}$   
 \* Rated data  
 \*\*ErP 2015

## Characteristic curve

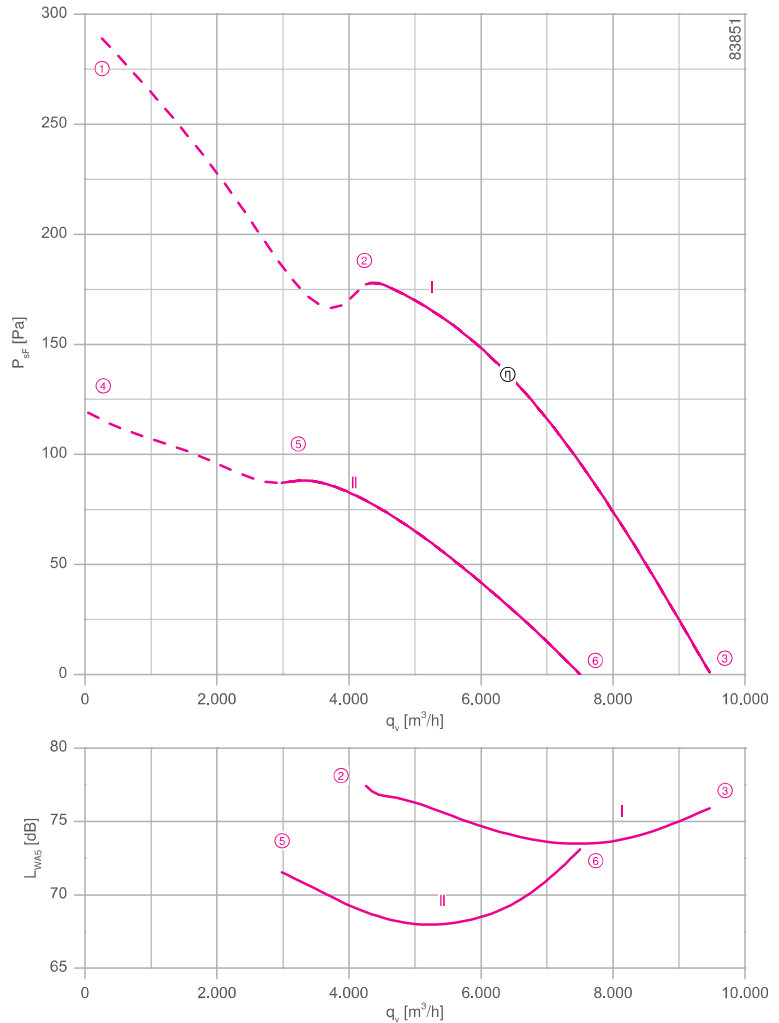

Measured in full bell mouth without guard grille in installation type A according to ISO 5801

Connection diagram Page 531  
 for airflow direction A 1360-108XB  
 for airflow direction V 1360-108XA

System components Page 430

## Dimensions mm

### Airflow direction A

Design W - axial bolted, mounting for short bell mouth, guard grille suction side

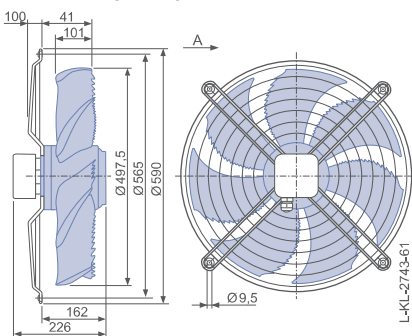

Design Q - square full bell mouth, guard grille suction side

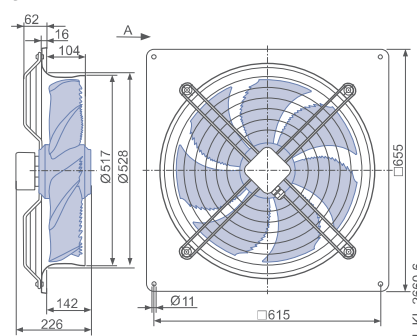

### Airflow direction V

Design K - axial bolted, mounted for short bell mouth, guard grille pressure side

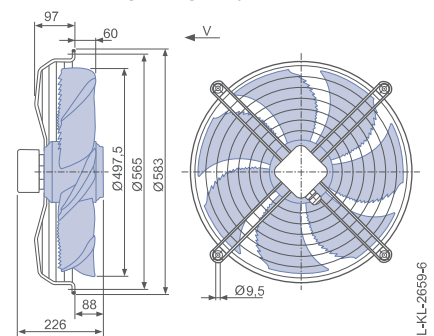







Performance data

Type	Connection	Characteristic curve	Voltage	Operating point	Current	Input power	Speed	Suction side sound power level $L_{WA5}$ dB(A)
			U V					
FN050-VD_4I_7P1	Δ	I	400	①	1.75	1050	1280	
			400*	②	1.45*	840*	1340*	78
			400	③	1.15	620	1390	76
	Y	II	400	④	1.05	580	800	
			400*	⑤	0.96*	540*	940*	72
			400	⑥	0.82	480	1110	73

\*rated data

Fan ordering information

Design	Airflow direction A			Airflow direction V		
	W (guard grille suction side)	Q (guard grille suction side)	K (guard grille pressure side)	F (without guard grille)	F (guard grille pressure side)	Q (guard grille pressure side)
						
<b>Type</b>	FN050-VDW.4I.A7P1	FN050-VDQ.4I.A7P1	FN050-VDK.4I.V7P1	FN050-VDF.4I.V7P1	FN050-VDF.4I.V7P1	FN050-VDQ.4I.V7P1
<b>Article no.</b>	156556	140083	140056	140067	140073	140322
<b>Weight kg</b>	13,80	20,10	13,30	16,80	17,50	18,30

Control technology

Frequency inverters Fcontrol 3~  Page 480	Motor protection units 3~  Page 518	Electronic voltage controllers 3~  Page 506
--	--	--

Design F - flange ring with two flanges, without guard grille

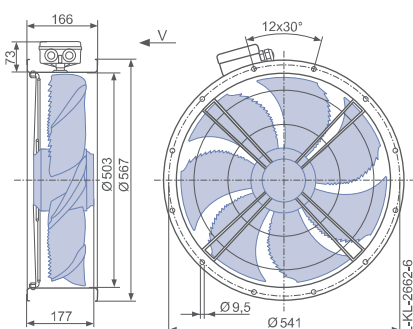

Design F - flange ring with two flanges, guard grille pressure side

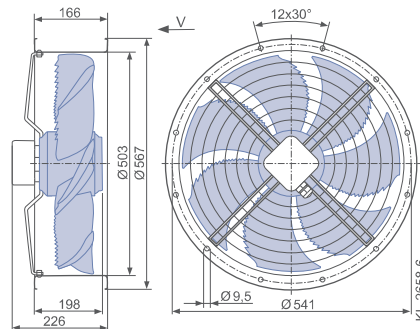

Design Q - square full bell mouth, guard grille pressure side

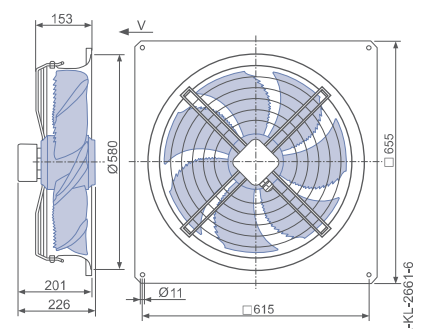



# FE2owlet

for three phase alternating current, 6-6 pole

FN050-SD

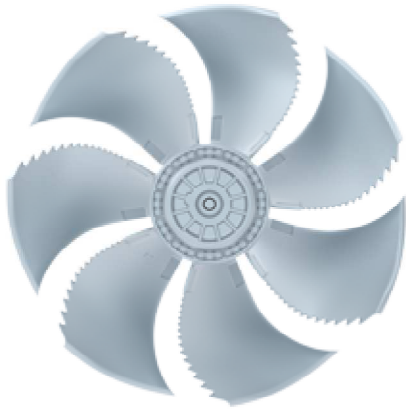

## Description

- Motor technology: AC
- Rated voltage  $U_N$ : 3- 400 V ( $\Delta/Y$ )  $\pm 10$  %\*
- Rated frequency  $f_N$ : 50 Hz\* (60Hz data available)
- Input power  $P_i$ : 290/150 W\*
- Rated current  $I_N$ : 0.74/0.36 A\*
- Rated speed  $n_N$ : 880/ 590 min<sup>-1</sup>\*
- Starting current  $I_s$ : 1.50 / 0.40 A
- Current increase  $\Delta I$ : 0 %
- Thermal class: THCL155\*
- Min. permitted ambient temperature  $t_{R(min)}$ : -40 °C
- Max. permitted ambient temperature  $t_{R(max)}$ : 70 °C
- Electrical connection: Terminal box
- Number of blades: 7
- Protection class: IP54
- Motor protection: thermal contact
- Blades: Aluminium, uncoated
- Rotor: Aluminium, uncoated
- Conformity: ErP 2015, CE
- ErP-data**
- Efficiency  $\eta_{stat A}$ : 30.1 %
- Efficiency:  $N_{actual} = 40.2 / N_{target} = 40$ \*\*
- \* Rated data
- \*\*ErP 2015

## Characteristic curve

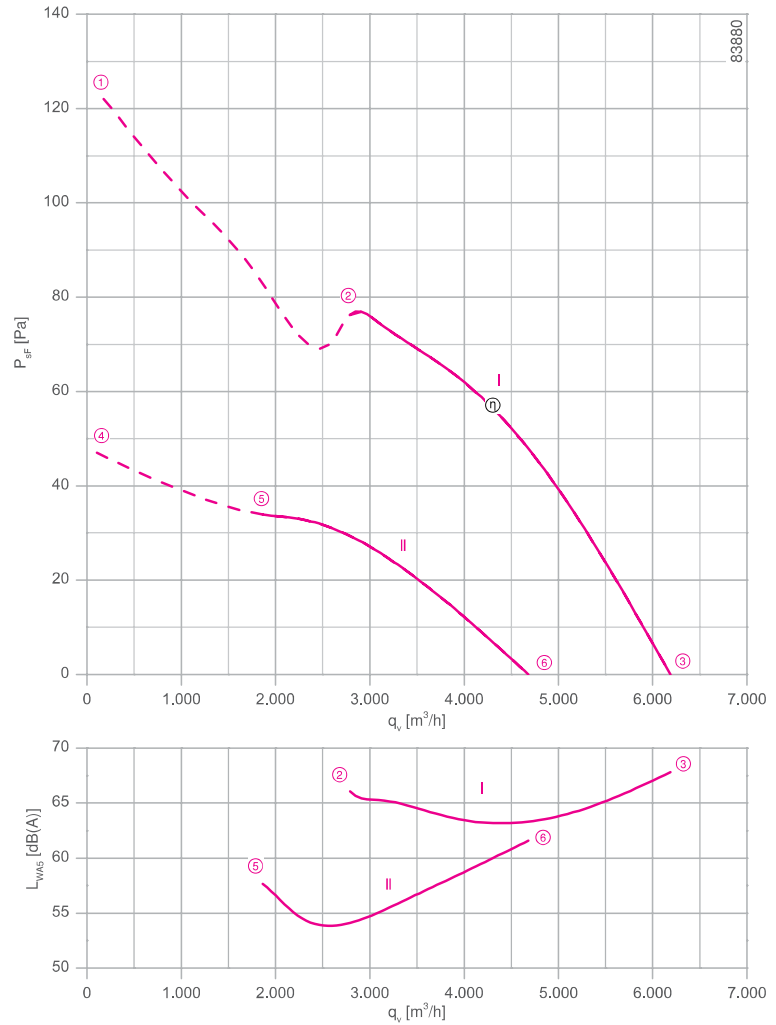

Connection diagram Page 531  
for airflow direction A 1360-108XB  
for airflow direction V 1360-108XA

System components Page 430

## Dimensions mm

**Airflow direction A**

Design W - axial bolted, mounting for short bell mouth, guard grille suction side

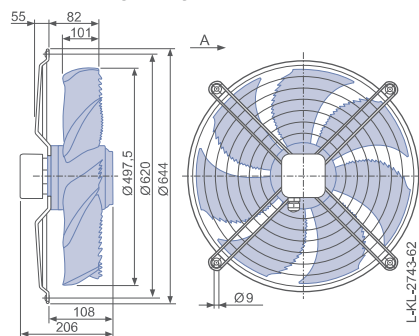

Design Q - square full bell mouth, guard grille suction side

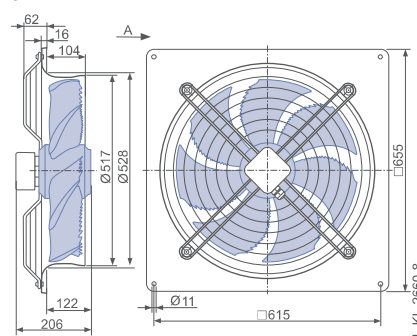

**Airflow direction V**

Design K - axial bolted, mounted for short bell mouth, guard grille pressure side

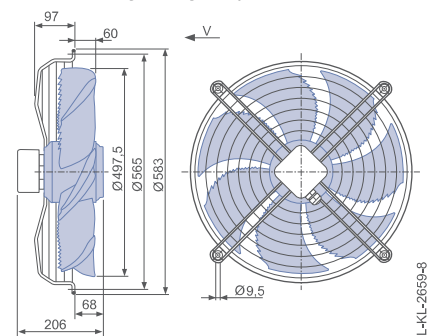







Performance data

Type	Connection	Characteristic curve	Voltage	Operating point	Current	Input power	Speed	Suction side sound power level $L_{WA5}$ dB(A)
			U V					
FN050-SD_4F_7P1	Δ	I	400	①	0.82	350	830	
			400*	②	0.74*	290*	880*	66
			400	③	0.66	230	920	68
	Y	II	400	④	0.38	160	510	
			400*	⑤	0.36*	150*	590*	58
			400	⑥	0.33	140	700	62

\*rated data

Fan ordering information

Design	Airflow direction A			Airflow direction V		
	W (guard grille suction side)	Q (guard grille suction side)	K (guard grille pressure side)	F (without guard grille)	F (guard grille pressure side)	Q (guard grille pressure side)
						
<b>Type</b>	<b>FN050-SDW.4F.A7P1</b>	<b>FN050-SDQ.4F.A7P1</b>	<b>FN050-SDK.4F.V7P1</b>	<b>FN050-SDF.4F.V7P1</b>	<b>FN050-SDF.4F.V7P1</b>	<b>FN050-SDQ.4F.V7P1</b>
<b>Article no.</b>	<b>155656</b>	<b>140085</b>	<b>140058</b>	<b>140069</b>	<b>140075</b>	<b>140063</b>
<b>Weight kg</b>	11,70	18,60	11,80	15,30	16,00	16,30

Control technology

<p>Frequency inverters Fcontrol 3~</p>  <p>Page 480</p>	<p>Motor protection units 3~</p>  <p>Page 518</p>	<p>Electronic voltage controllers 3~</p>  <p>Page 506</p>
---	---	---

Design F - flange ring with two flanges, without guard grille

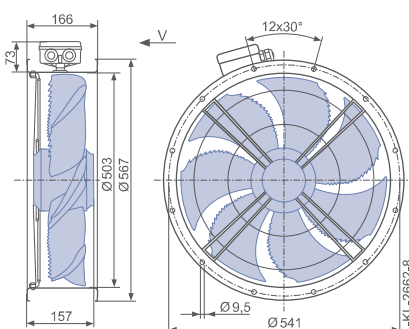

Design F - flange ring with two flanges, guard grille pressure side

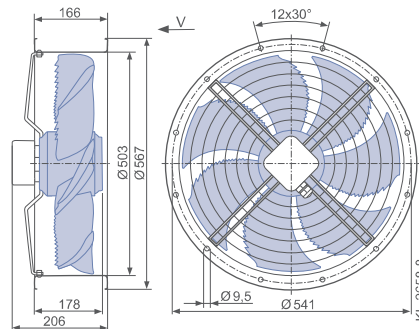

Design Q - square full bell mouth, guard grille pressure side

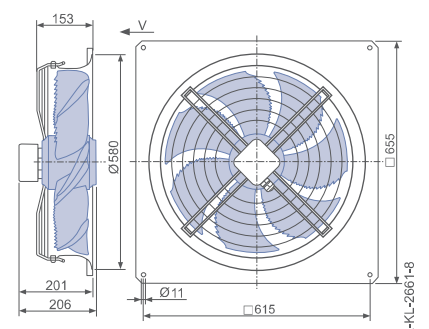

# FE2owlet

for three phase alternating current, 8-8 pole

FN050-AD

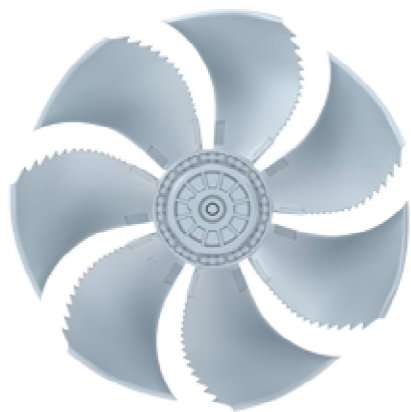

## Description

Motor technology: AC  
 Rated voltage  $U_N$ : 3- 400 V ( $\Delta/Y$ )  $\pm 10$  %\*  
 Rated frequency  $f_N$ : 50 Hz\* (60Hz data available)  
 Input power  $P_i$ : 130/80 W\*  
 Rated current  $I_N$ : 0.30/0.15 A\*  
 Rated speed  $n_N$ : 660/510 min<sup>-1</sup>\*  
 Starting current  $I_s$ : 0.70 / 0.22 A  
 Current increase  $\Delta I$ : 0 %  
 Thermal class: THCL155\*  
 Min. permitted ambient temperature  $t_{R(min)}$ : -40 °C  
 Max. permitted ambient temperature  $t_{R(max)}$ : 70 °C  
 Electrical connection: Terminal box  
 Number of blades: 7  
 Protection class: IP54  
 Motor protection: thermal contact  
 Blades: Aluminium, uncoated  
 Rotor: Aluminium, uncoated  
 Conformity: CE  
**ErP-data**  
 Not subject to the regulations of ErP directive ( $P_i < 125$  W)  
 \* Rated data

## Characteristic curve

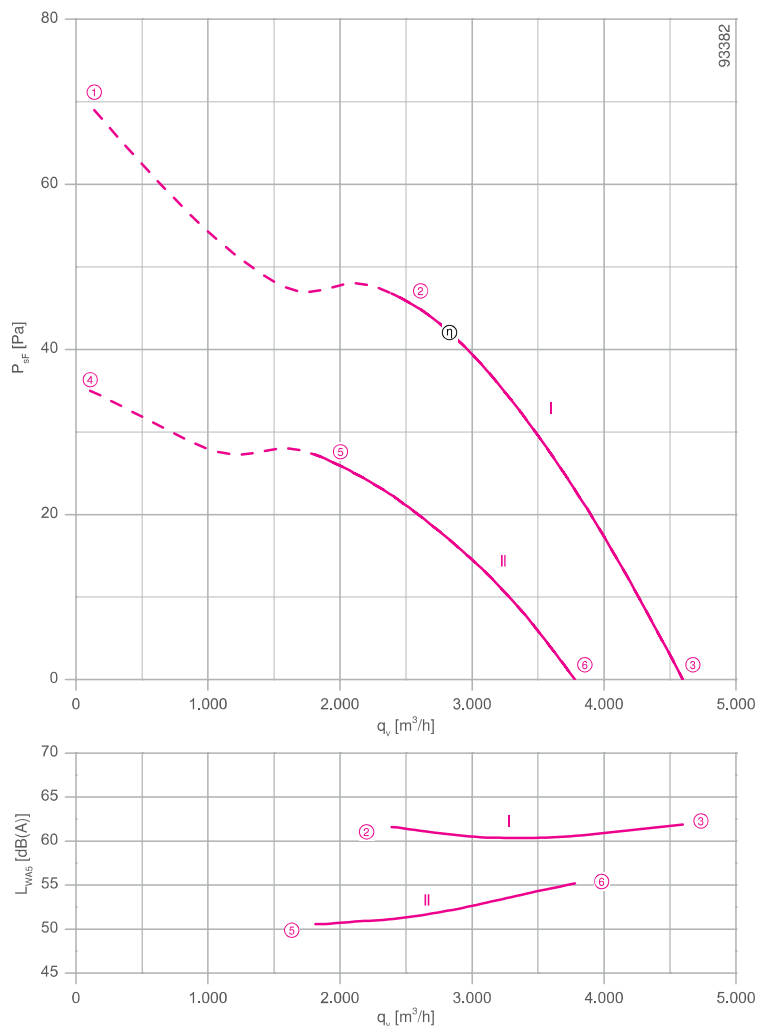

Measured in full bell mouth without guard grille in installation type A according to ISO 5801

Connection diagram Page 531  
 for airflow direction A 1360-108XB  
 for airflow direction V 1360-108XA

System components Page 430

## Dimensions mm

### Airflow direction A

Design Q - square full bell mouth, guard grille suction side

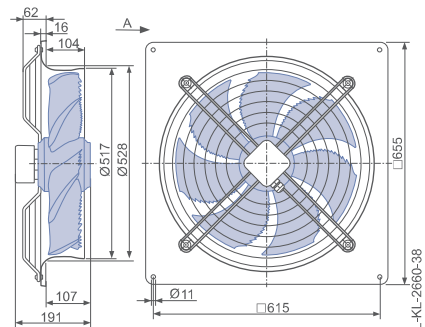

### Airflow direction V

Design K - axial bolted, mounted for short bell mouth, guard grille pressure side

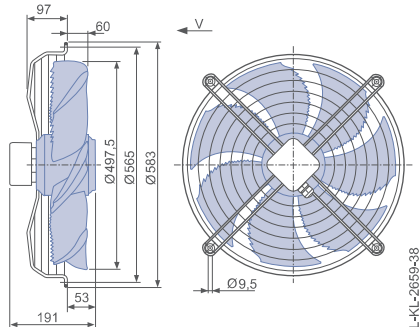

Design F - flange ring with two flanges, without guard grille

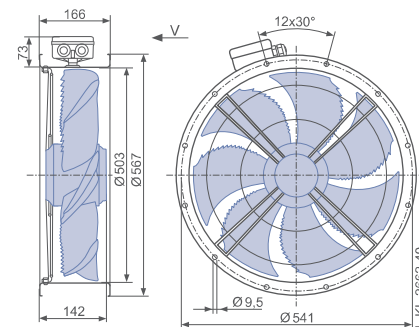

Performance data

Type	Connection	Characteristic curve	Voltage	Operating point	Current	Input power	Speed	Suction side sound power level $L_{WA5}$ dB(A)
			U V					
FN050-AD_4C_7P1	Δ	I	400	①	0.32	150	640	
			400*	②	0.30*	130*	660*	62
			400	③	0.28	100	690	62
	Y	II	400	④	0.16	90	450	
			400*	⑤	0.15*	80*	510*	51
			400	⑥	0.13	70	570	55

\*rated data

Fan ordering information

	Airflow direction A	Airflow direction V			
Design	Q (guard grille suction side)	K (guard grille pressure side)	F (without guard grille)	F (guard grille pressure side)	Q (guard grille pressure side)
Type	FN050-ADQ.4C.A7P1	FN050-ADK.4C.V7P1	FN050-ADF.4C.V7P1	FN050-ADF.4C.V7P1	FN050-ADQ.4C.V7P1
Article no.	160053	160055	160057	160058	160056
Weight kg	16.90	10.10	13.60	16.10	14.60

Control technology

Frequency inverters Fcontrol 3~	Motor protection units 3~	Electronic voltage controllers 3~
Page 480	Page 518	Page 506

Design F - flange ring with two flanges, guard grille pressure side

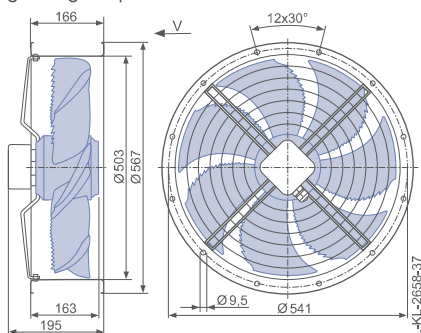

Design Q - square full bell mouth, guard grille pressure side

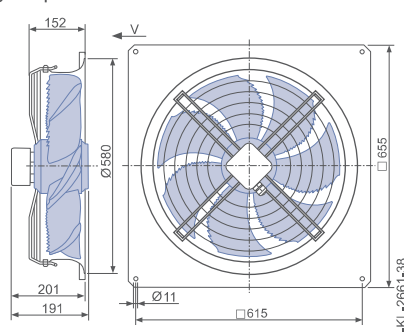

# FE2owlet

for single phase alternating current, 6 pole

FN056-6E



### Description

Motor technology: AC  
Rated voltage  $U_N$ : 1~ 230 V $\pm$ 10 %  
Rated frequency  $f_N$ : 50 Hz\* (60Hz data available)  
Input power  $P_i$ : 0.39 kW\*  
Rated current  $I_N$ : 1.80 A\*  
Rated speed  $n_N$ : 910 min $^{-1}$ \*  
Starting current  $I_A$ : 4.20 A  
Current increase  $\Delta I$ : 15 %  
Service capacitor  $C_{400V}$ : 8.0  $\mu$ F  
Thermal class: THCL155\*  
Min. permitted ambient temperature  $t_{R(min)}$ : -25 °C  
Max. permitted ambient temperature  $t_{R(max)}$ : 70 °C  
Electrical connection: Terminal box  
Number of blades: 7  
Protection class: IP54  
Motor protection: thermal contact  
Blades: Aluminium, uncoated  
Rotor: Aluminium, uncoated  
Conformity: ErP 2015, CE

### ErP-data

Efficiency  $\eta_{statA}$ : 33.0 %  
Efficiency:  $N_{actual} = 42.0 / N_{target} = 40$ \*\*  
\* Rated data  
\*\*ErP 2015

### Characteristic curve

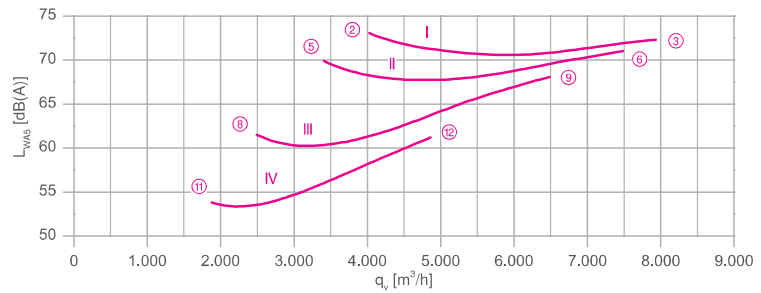
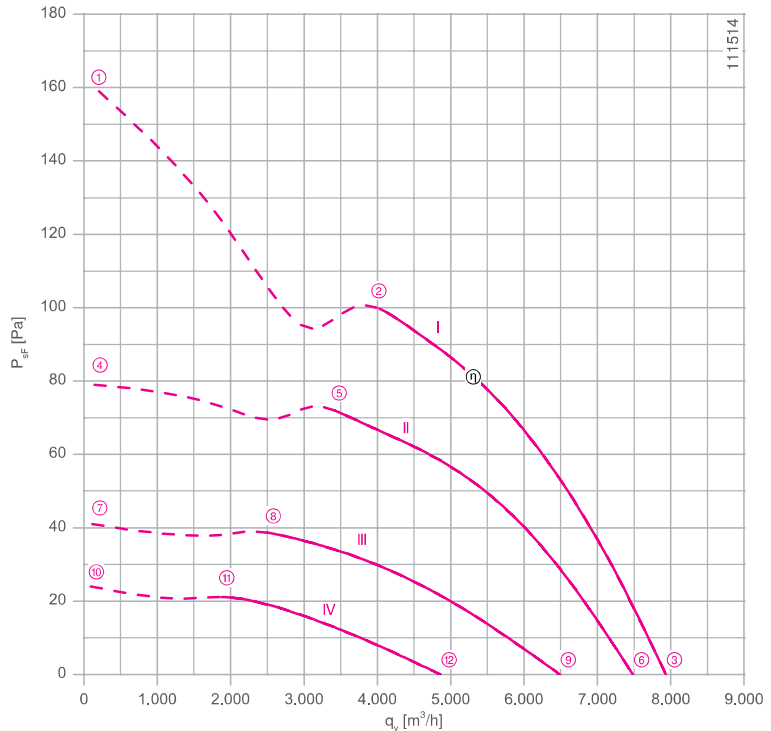

Measured in full bell mouth without guard grille in installation type A according to ISO 5801

Connection diagram Page 531  
for airflow direction A 1360-104XB  
for airflow direction V 1360-104XA

System components Page 430

### Dimensions mm

Airflow direction A

Design W - axial bolted, mounting for short bell mouth, guard grille suction side

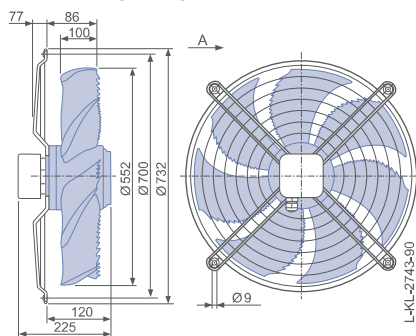

Design Q - square full bell mouth, guard grille suction side

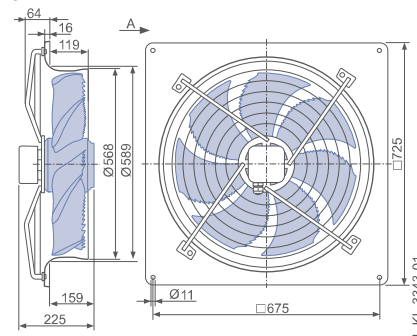

Airflow direction V

Design F - flange ring with two flanges, guard grille suction side

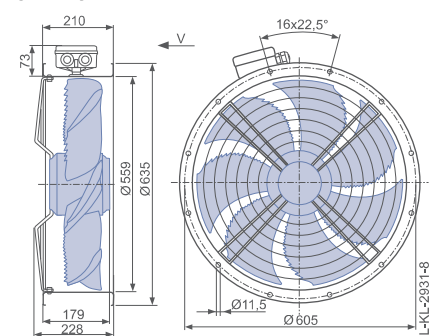





Performance data

Type	Characteristic curve	Voltage	Operating point	Current	Input power	Speed	Suction side sound power level $L_{WA5}$ dB(A)
		U V		I A	$P_1$ W	n min <sup>-1</sup>	
FN056-6E_.4I_.7P2	I	230	①	2.40	500	850	
		230*	②	1.80*	390*	910*	73
		230	③	1.40	290	950	72
	II	170	④	2.50	370	590	
		170	⑤	2.00	320	770	70
		170	⑥	1.40	230	900	71
	III	135	⑦	2.10	250	430	
		135	⑧	2.00	240	570	62
		135	⑨	1.60	200	780	68
	IV	110	⑩	1.75	160	320	
		110	⑪	1.70	160	420	54
		110	⑫	1.60	160	580	61

\*rated data

Fan ordering information

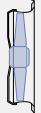
Design	Airflow direction A		Airflow direction V		
	W (guard grille suction side)	Q (guard grille suction side)	F (guard grille suction side)	K (guard grille pressure side)	Q (guard grille pressure side)
					
Type	FN056-6EW.4I.A7P2	FN056-6EQ.4I.A7P2	FN056-6EF.4I.V7P2	FN056-6EK.4I.V7P2	FN056-6EQ.4I.V7P2
Article no.	167570	167571	167576	167573	167574
Weight kg	14.10	22.20	19.30	13.30	21.00

Control technology

Frequency inverters Fcontrol 1~  Page 474	Motor protection units 1~  Page 518	Electronic voltage controllers 1~  Page 492
---	---	--

Design K - axial bolted, mounted for short bell mouth, guard grille pressure side

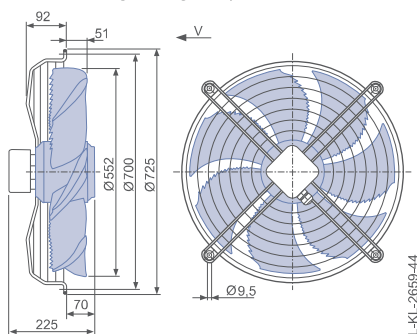

Design Q - square full bell mouth, guard grille pressure side

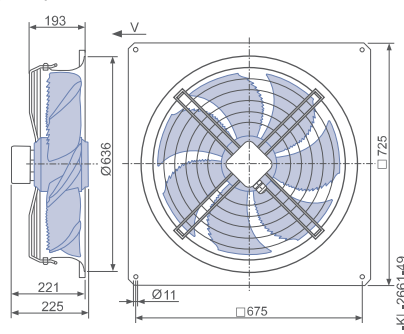

# FE2owlet

for three phase alternating current, 4-4 pole

FN056-VD



### Description

Motor technology: AC  
 Rated voltage  $U_N$ : 3- 400 V ( $\Delta/Y$ )  $\pm 10$  %\*  
 Rated frequency  $f_N$ : 50 Hz\* (60Hz data available)  
 Input power  $P_i$ : 1.05/0.58 kW\*  
 Rated current  $I_N$ : 2.20/1.10 A\*  
 Rated speed  $n_N$ : 1280/910 min<sup>-1</sup>\*  
 Starting current  $I_s$ : 6.50 / 1.90 A  
 Current increase  $\Delta I$ : 0 %  
 Thermal class: THCL155\*  
 Min. permitted ambient temperature  $t_{R(min)}$ : -40 °C  
 Max. permitted ambient temperature  $t_{R(max)}$ : 70 °C  
 Electrical connection: Terminal box  
 Number of blades: 7  
 Protection class: IP54  
 Motor protection: thermal contact  
 Blades: Aluminium, uncoated  
 Rotor: Aluminium, uncoated  
 Conformity: ErP 2015, CE  
**ErP-data**  
 Efficiency  $\eta_{statA}$ : 33.7 %  
 Efficiency:  $N_{actual} = 40.1 / N_{target} = 40$ \*\*  
 \* Rated data  
 \*\*ErP 2015

### Characteristic curve

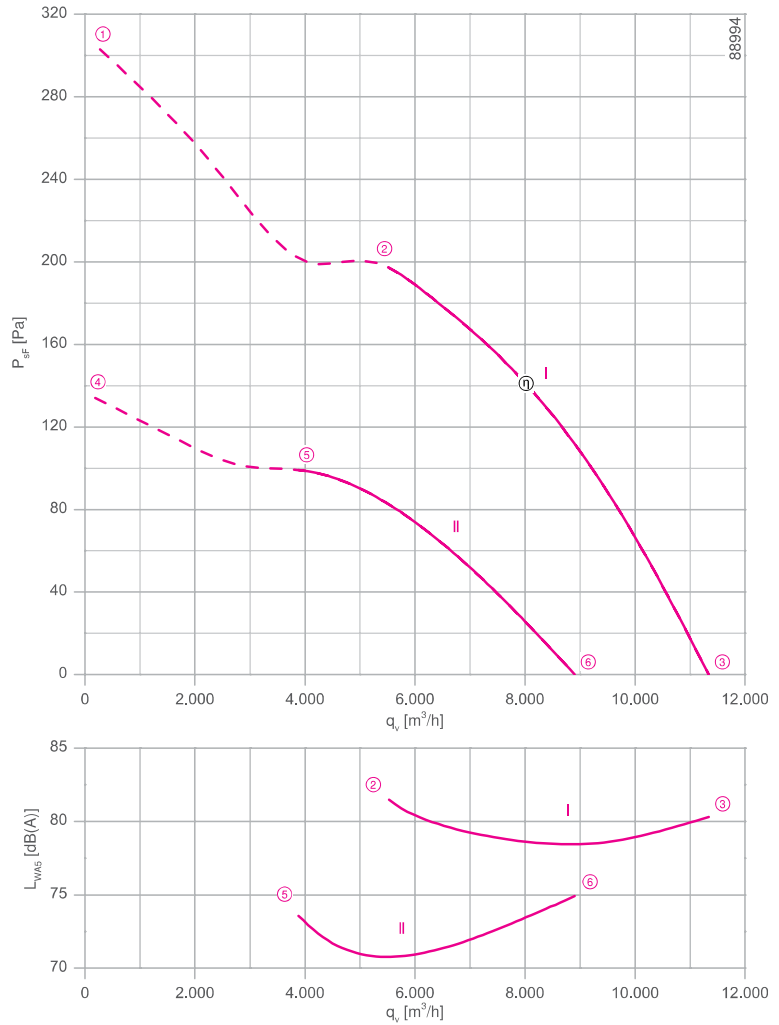

Measured in full bell mouth without guard grille in installation type A according to ISO 5801

Connection diagram Page 531  
 for airflow direction A 1360-108XB  
 for airflow direction V 1360-108XA

System components Page 430

### Dimensions mm

#### Airflow direction A

Design W - axial bolted, mounting for short bell mouth, guard grille suction side

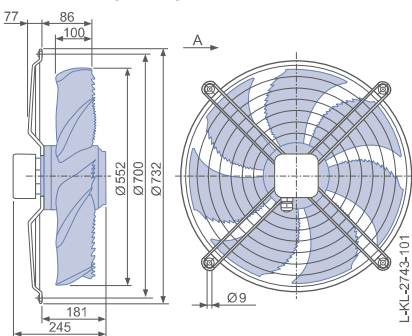

Design Q - square full bell mouth, guard grille suction side

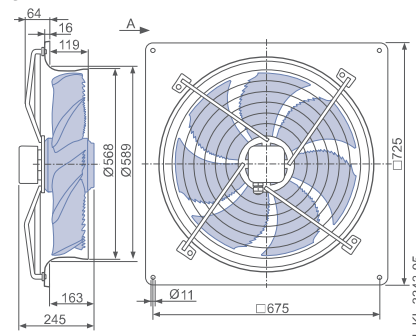

#### Airflow direction V

Design K - axial bolted, mounted for short bell mouth, guard grille pressure side

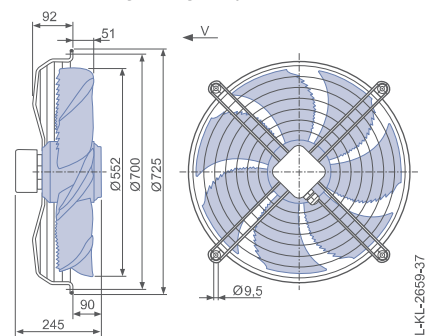

Performance data

Type	Connection	Characteristic curve	Voltage	Operating point	Current	Input power	Speed	Suction side sound power level $L_{WA5}$ dB(A)
			U V					
FN056-VD_4M_7P2	Δ	I	400	①	2.60	1300	1190	
			400*	②	2.20*	1050*	1280*	82
			400	③	1.75	740	1370	80
	Y	II	400	④	1.20	640	790	
			400*	⑤	1.10*	580*	910*	73
			400	⑥	0.94	480	1080	75

\*rated data

Fan ordering information

Design	Airflow direction A			Airflow direction V		
	W (guard grille suction side)	Q (guard grille suction side)	K (guard grille pressure side)	F (without guard grille)	F (guard grille pressure side)	Q (guard grille pressure side)
<b>Type</b>	<b>FN056-VDW.4M.A7P2</b>	<b>FN056-VDQ.4M.A7P2</b>	<b>FN056-VDK.4M.V7P2</b>	<b>FN056-VDF.4M.V7P2</b>	<b>FN056-VDF.4M.V7P2</b>	<b>FN056-VDQ.4M.V7P2</b>
<b>Article no.</b>	<b>159439</b>	<b>159441</b>	<b>159443</b>	<b>159447</b>	<b>159446</b>	<b>159445</b>
<b>Weight kg</b>	16,10	24,20	15,40	20,40	21,30	23,20

Control technology

Frequency inverters Fcontrol 3~	Motor protection units 3~	Electronic voltage controllers 3~
Page 480	Page 518	Page 506

Design F - flange ring with two flanges, without guard grille

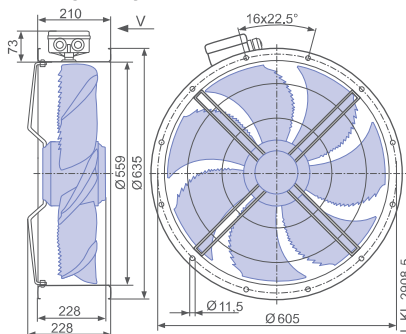

Design F - flange ring with two flanges, guard grille pressure side

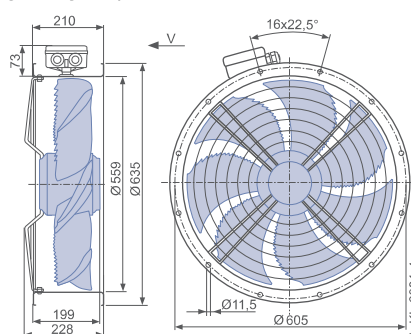

Design Q - square full bell mouth, guard grille pressure side

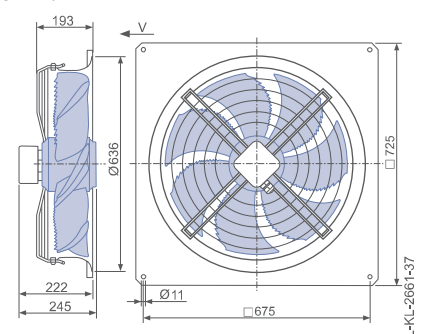











Performance data

Type	Connection	Characteristic curve	Voltage	Operating point	Current	Input power	Speed	Suction side sound power level $L_{WA5}$ dB(A)
			U V					
FN056-SD_4F_7P2	Δ	I	400	①	0.84	440	810	
			400*	②	0.70*	340*	870*	72
			400	③	0.58	250	920	72
	Y	II	400	④	0.42	230	530	
			400*	⑤	0.38*	210*	630*	64
			400	⑥	0.31	170	750	67

\*rated data

Fan ordering information

Design	Airflow direction A			Airflow direction V		
	W (guard grille suction side)	Q (guard grille suction side)	K (guard grille pressure side)	F (without guard grille)	F (guard grille pressure side)	Q (guard grille pressure side)
						
<b>Type</b>	<b>FN056-SDW.4F.A7P2</b>	<b>FN056-SDQ.4F.A7P2</b>	<b>FN056-SDK.4F.V7P2</b>	<b>FN056-SDF.4F.V7P2</b>	<b>FN056-SDF.4F.V7P2</b>	<b>FN056-SDQ.4F.V7P2</b>
<b>Article no.</b>	<b>159449</b>	<b>159451</b>	<b>159453</b>	<b>159457</b>	<b>159456</b>	<b>159455</b>
<b>Weight kg</b>	12.70	22.20	11.90	17.00	17.90	19.80

Control technology

Frequency inverters Fcontrol 3~	Motor protection units 3~	Electronic voltage controllers 3~
		
Page 480	Page 518	Page 506

Design F - flange ring with two flanges, without guard grille

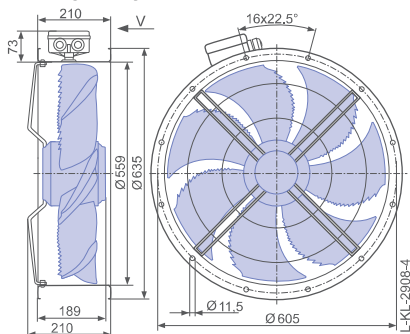

Design F - flange ring with two flanges, guard grille pressure side

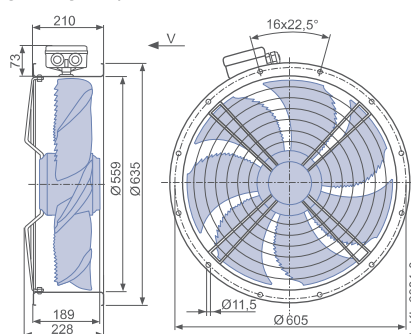

Design Q - square full bell mouth, guard grille pressure side

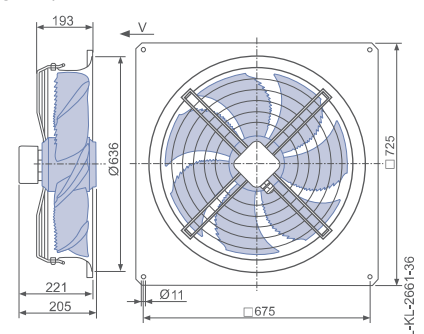

# FE2owlet

for single phase alternating current, 4 pole

FN063-4E



## Description

Motor technology: AC  
 Rated voltage  $U_N$ : 1~ 230 V $\pm$ 10 %\*  
 Rated frequency  $f_N$ : 50 Hz\* (60Hz data available)  
 Input power  $P_i$ : 1.85 kW\*  
 Rated current  $I_N$ : 7.70 A\*  
 Rated speed  $n_N$ : 1360 min<sup>-1</sup>\*  
 Current increase  $\Delta I$ : 20 %  
 Service capacitor  $C_{400V}$ : 35.0  $\mu$ F  
 Thermal class: THCL155\*  
 Min. permitted ambient temperature  $t_{R(min)}$ : -25 °C  
 Max. permitted ambient temperature  $t_{R(max)}$ : 55 °C  
 Electrical connection: Terminal box  
 Number of blades: 7  
 Protection class: IP54  
 Motor protection: thermal contact  
 Blades: Aluminium, uncoated  
 Rotor: Aluminium, uncoated  
 Conformity: ErP 2015, CE  
**ErP-data**  
 Efficiency  $\eta_{statA}$ : 36.5 %  
 Efficiency:  $N_{actual} = 41.3 / N_{target} = 40^{**}$   
 \* Rated data  
 \*\*ErP 2015

## Characteristic curve

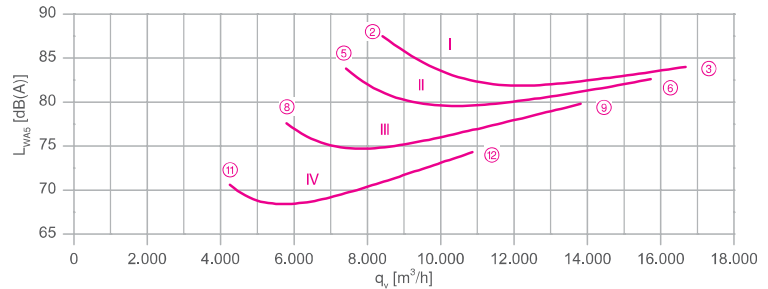
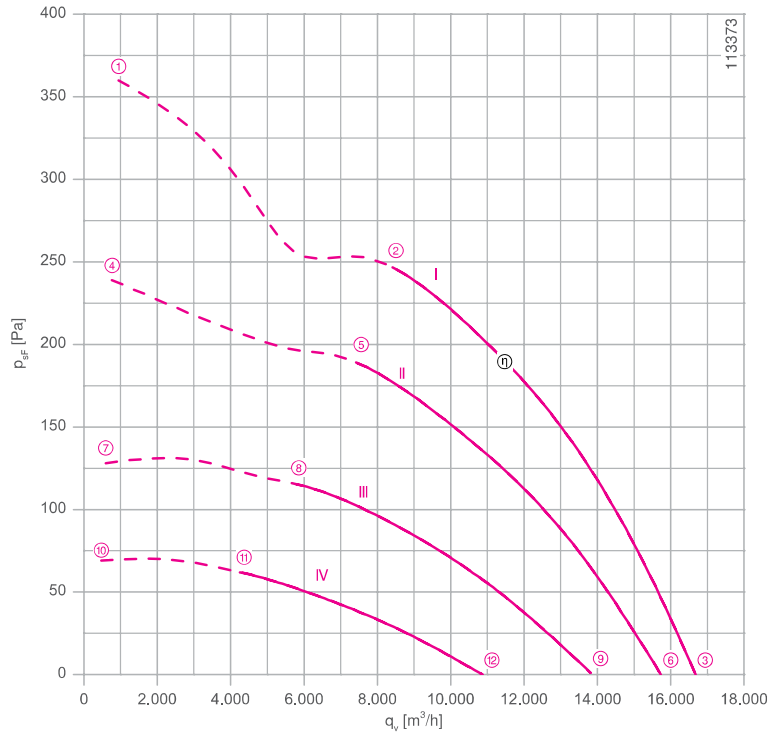

Measured in full bell mouth without guard grille in installation type A according to ISO 5801

Connection diagram Page 531  
 for airflow direction A 1360-104XB  
 for airflow direction V 1360-104XA

System components Page 430

## Dimensions mm

### Airflow direction A

Design W - axial bolted, mounting for short bell mouth, guard grille suction side

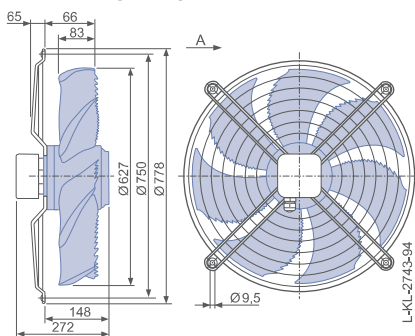

Design Q - square full bell mouth, guard grille suction side

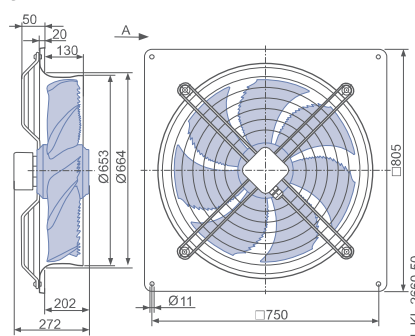

### Airflow direction V

Design K - axial bolted, mounted for short bell mouth, guard grille pressure side

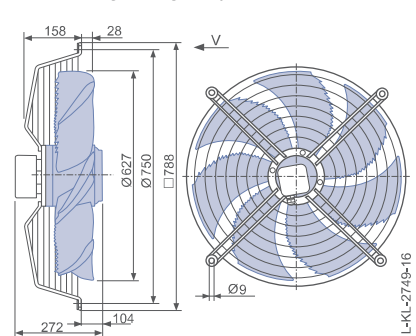





Performance data

Type	Characteristic curve	Voltage	Operating point	Current	Input power	Speed	Suction side sound power level $L_{WA5}$ dB(A)
		U V		I A	$P_1$ W	n min <sup>-1</sup>	
FN063-4E_6N_7P6	I	230	①	9.40	2100	1340	
		230*	②	8.00*	1800*	1380*	88
		230	③	5.80	1300	1420	84
	II	170	④	11.50	1800	1080	
		170	⑤	9.60	1550	1210	84
		170	⑥	7.00	1150	1330	83
	III	135	⑦	11.00	1350	790	
		135	⑧	10.50	1300	950	78
		135	⑨	8.20	1050	1180	80
	IV	110	⑩	9.60	940	580	
		110	⑪	9.40	920	690	71
		110	⑫	8.40	860	920	74

\*rated data

Fan ordering information

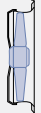
Design	Airflow direction A		Airflow direction V		
	W (guard grille suction side)	Q (guard grille suction side)	K (guard grille pressure side)	F (guard grille pressure side)	Q (guard grille pressure side)
					
<b>Type</b>	<b>FN063-4EW.6N.A7P6</b>	<b>FN063-4EQ.6N.A7P6</b>	<b>FN063-4EK.6N.V7P6</b>	<b>FN063-4EF.6N.V7P6</b>	<b>FN063-4EQ.6N.V7P6</b>
<b>Article no.</b>	<b>169020</b>	<b>169021</b>	<b>169017</b>	<b>169016</b>	<b>169018</b>
<b>Weight kg</b>	25.90	36.20	28.10	32.80	38.00

Control technology

<p>Frequency inverters Fcontrol 1~</p>  <p>Page 474</p>	<p>Motor protection units 1~</p>  <p>Page 518</p>	<p>Electronic voltage controllers 1~</p>  <p>Page 492</p>
--	--	--

Design F - flange ring with two flanges, guard grille pressure side

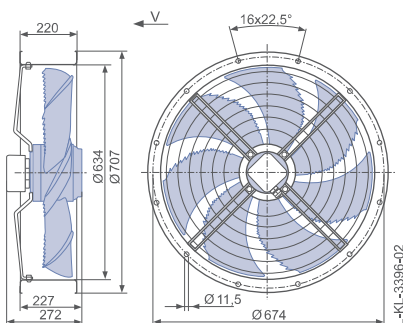

Design Q - square full bell mouth, guard grille pressure side

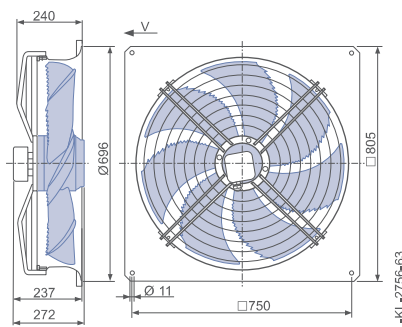

# FE2owlet

for single phase alternating current, 6 pole

FN063-6E

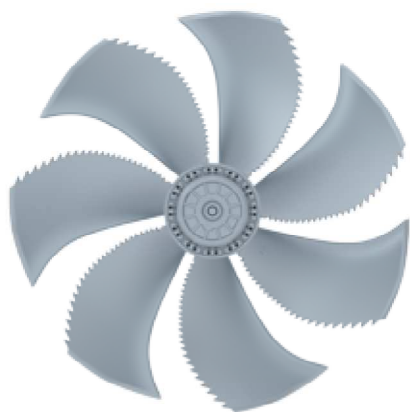

## Description

Motor technology: AC  
 Rated voltage  $U_N$ : 1~ 230 V $\pm$ 10 %\*  
 Rated frequency  $f_N$ : 50 Hz\* (60Hz data available)  
 Input power  $P_i$ : 0.66 kW\*  
 Rated current  $I_N$ : 3.00 A\*  
 Rated speed  $n_N$ : 860 min<sup>-1</sup>\*  
 Starting current  $I_s$ : 5.50 A  
 Current increase  $\Delta I$ : 0 %  
 Service capacitor  $C_{400V}$ : 12.0  $\mu$ F  
 Thermal class: THCL155\*  
 Min. permitted ambient temperature  $t_{R(min)}$ : -25 °C  
 Max. permitted ambient temperature  $t_{R(max)}$ : 70 °C  
 Electrical connection: Terminal box  
 Number of blades: 7  
 Protection class: IP54  
 Motor protection: thermal contact  
 Blades: Aluminium, uncoated  
 Rotor: Aluminium, uncoated  
 Conformity: ErP 2015, CE

## ErP-data

Efficiency  $\eta_{statA}$ : 32.2 %  
 Efficiency:  $N_{actual} = 40.0 / N_{target} = 40$ \*\*

\* Rated data

\*\*ErP 2015

Connection diagram Page 531  
 for airflow direction A 1360-104XB  
 for airflow direction V 1360-104XA

System components Page 430

## Characteristic curve

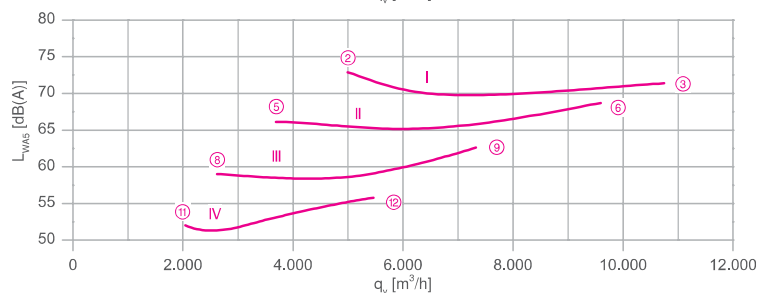
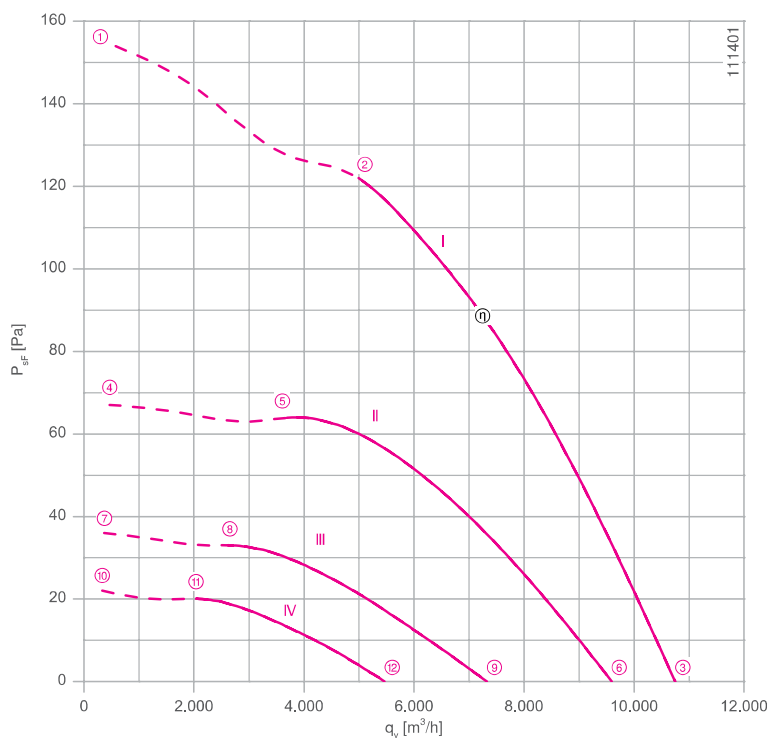

Measured in full bell mouth without guard grille in installation type A according to ISO 5801

## Dimensions mm

### Airflow direction A

Design W - axial bolted, mounting for short bell mouth, guard grille suction side

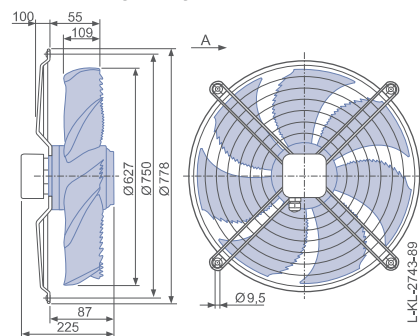

Design Q - square full bell mouth, guard grille suction side

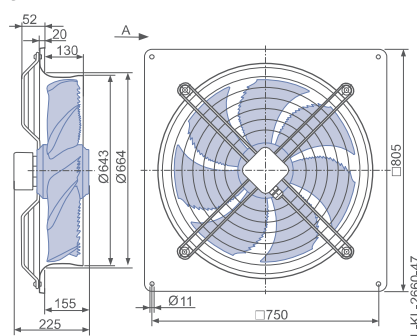

### Airflow direction V

Design K - axial bolted, mounted for short bell mouth, guard grille pressure side

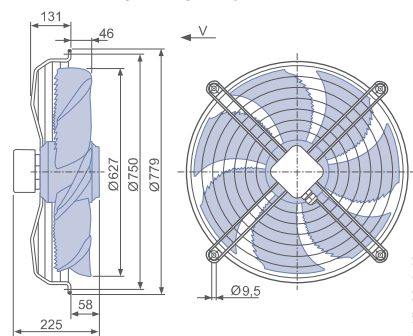

Performance data

Type	Characteristic curve	Voltage	Operating point	Current	Input power	Speed	Suction side sound power level $L_{WA5}$ dB(A)
		U V		I A	$P_1$ W	n min <sup>-1</sup>	
FN063-6E_4I_7P1	I	230	①	3.70	780	770	73
		230*	②	2.90*	640*	870*	
		230	③	2.20	480	930	
	II	170	④	3.20	480	510	66
		170	⑤	3.00	460	630	
		170	⑥	2.30	370	840	
	III	135	⑦	2.60	300	370	59
		135	⑧	2.50	300	460	
		135	⑨	2.30	280	640	
	IV	110	⑩	2.10	200	290	52
		110	⑪	2.10	200	350	
		110	⑫	2.00	190	480	

\*rated data

Fan ordering information

Design	Airflow direction A			Airflow direction V		
	W (guard grille suction side)	Q (guard grille suction side)	K (guard grille pressure side)	F (without guard grille)	F (guard grille pressure side)	Q (guard grille pressure side)
Type	FN063-6EW.4I.A7P1	FN063-6EQ.4I.A7P1	FN063-6EK.4I.V7P1	FN063-6EF.4I.V7P1	FN063-6EF.4I.V7P1	FN063-6EQ.4I.V7P1
Article no.	167969	167968	167972	167973	167974	167971
Weight kg	14.30	24.50	15.40	19.90	20.80	23.90

Control technology

Frequency inverters Fcontrol 1~  Page 474	Motor protection units 1~  Page 518	Electronic voltage controllers 1~  Page 492
--	--	---

Design F - flange ring with two flanges, without guard grille

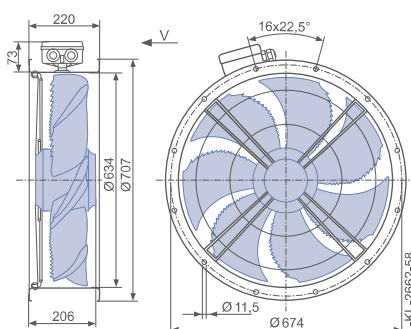

Design F - flange ring with two flanges, guard grille pressure side

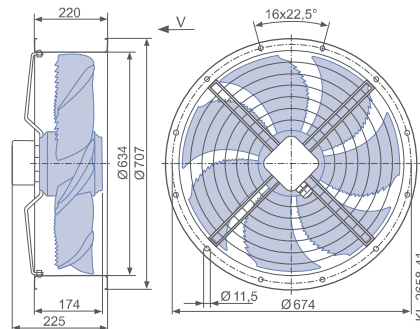

Design Q - square full bell mouth, guard grille pressure side

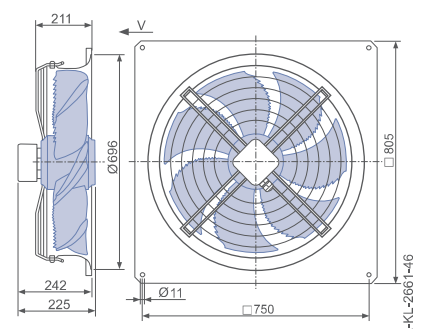

# FE2owlet

for three phase alternating current, 4-4 pole

FN063-VD



## Description

Motor technology: AC  
 Rated voltage  $U_N$ : 3- 400 V ( $\Delta/Y$ )  $\pm 10$  %\*  
 Rated frequency  $f_N$ : 50 Hz\* (60Hz data available)  
 Input power  $P_i$ : 1.75/1.35 kW\*  
 Rated current  $I_N$ : 3.70/2.20 A\*  
 Rated speed  $n_N$ : 1400/1210 min<sup>-1</sup>\*  
 Starting current  $I_s$ : 20.00 / 6.50 A  
 Current increase  $\Delta I$ : 5 %  
 Thermal class: THCL155\*  
 Min. permitted ambient temperature  $t_{R(min)}$ : -40 °C  
 Max. permitted ambient temperature  $t_{R(max)}$ : 70 °C  
 Electrical connection: Terminal box  
 Number of blades: 7  
 Protection class: IP54  
 Motor protection: thermal contact  
 Blades: Aluminium, uncoated  
 Rotor: Aluminium, uncoated  
 Conformity: ErP 2015, CE  
**ErP-data**  
 Efficiency  $\eta_{stat^A}$ : 37.5 %  
 Efficiency:  $N_{actual} = 42.5 / N_{target} = 40$ \*\*  
 \* Rated data  
 \*\*ErP 2015

## Characteristic curve

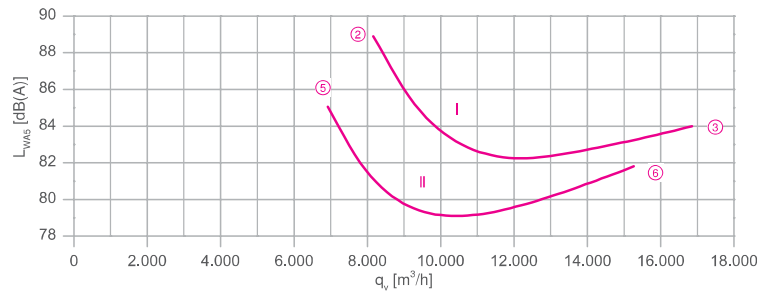
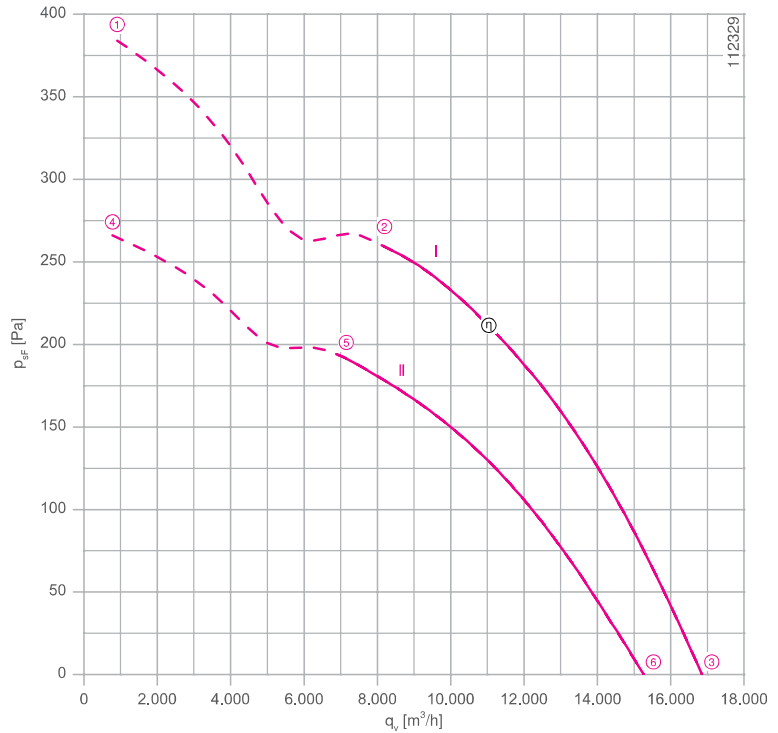

Measured in full bell mouth without guard grille in installation type A according to ISO 5801

Connection diagram Page 531  
 for airflow direction A 1360-108XB  
 for airflow direction V 1360-108XA

System components Page 430

## Dimensions mm

### Airflow direction A

Design W - axial bolted, mounting for short bell mouth, guard grille suction side

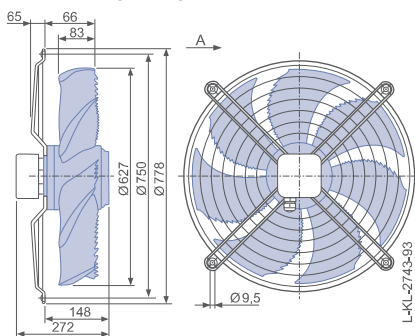

Design Q - square full bell mouth, guard grille suction side

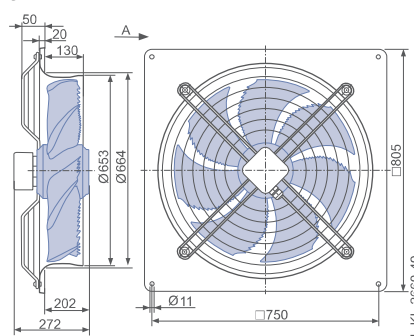

### Airflow direction V

Design K - axial bolted, mounted for short bell mouth, guard grille pressure side

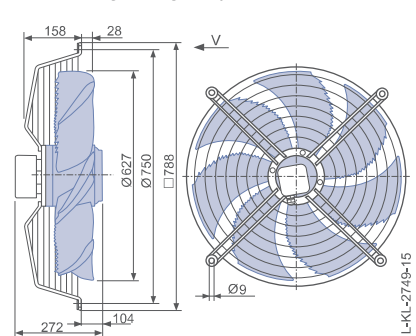





Performance data

Type	Connection	Characteristic curve	Voltage	Operating point	Current	Input power	Speed	Suction side sound power level $L_{WA5}$ dB(A)
			U V					
FN063-VD_6N_7P6	Δ	I	400	①	4.20	2100	1380	
			400*	②	3.70*	1750*	1400*	89
			400	③	3.10	1250	1430	84
	Y	II	400	④	2.60	1550	1140	
			400*	⑤	2.20*	1350*	1210*	85
			400	⑥	1.75	1000	1300	82

\*rated data

Fan ordering information

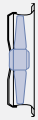
Design	Airflow direction A		Airflow direction V		
	W (guard grille suction side)	Q (guard grille suction side)	K (guard grille pressure side)	F (guard grille pressure side)	Q (guard grille pressure side)
					
<b>Type</b>	<b>FN063-VDW.6N.A7P6</b>	<b>FN063-VDQ.6N.A7P6</b>	<b>FN063-VDK.6N.V7P6</b>	<b>FN063-VDF.6N.V7P6</b>	<b>FN063-VDQ.6N.V7P6</b>
<b>Article no.</b>	<b>169014</b>	<b>169015</b>	<b>169011</b>	<b>169010</b>	<b>169012</b>
<b>Weight kg</b>	25,90	36,20	28,10	32,80	38,00

Control technology

Frequency inverters Fcontrol 3~  Page 480	Motor protection units 3~  Page 518	Electronic voltage controllers 3~  Page 506
--	--	--

Design F - flange ring with two flanges, guard grille pressure side

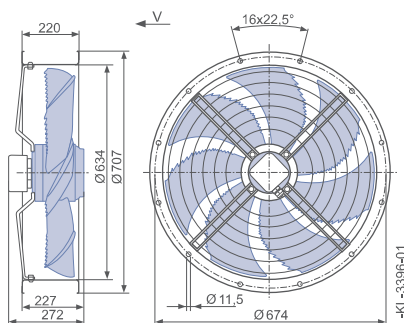

Design Q - square full bell mouth, guard grille pressure side

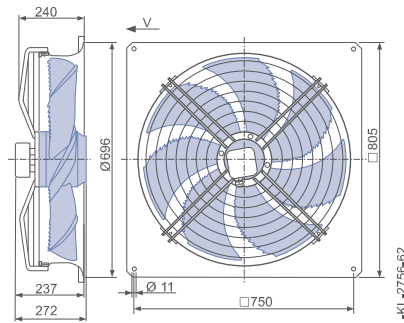



# FE2owlet

for three phase alternating current, 4-4 pole

FN063-VD



## Description

Motor technology: AC  
 Rated voltage  $U_N$ : 3- 400 V ( $\Delta/Y$ )  $\pm 10\%$ \*  
 Rated frequency  $f_N$ : 50 Hz\*  
 Input power  $P_i$ : 2.60/1.75 kW\*  
 Rated current  $I_N$ : 5.00/3.00 A\*  
 Rated speed  $n_N$ : 1330/1050 min<sup>-1</sup>\*  
 Starting current  $I_s$ : 19.00 / 6.00 A  
 Current increase  $\Delta I$ : 5 %  
 Thermal class: THCL155\*  
 Min. permitted ambient temperature  $t_{R(min)}$ : -40 °C  
 Max. permitted ambient temperature  $t_{R(max)}$ : 60 °C  
 Electrical connection: Terminal box  
 Number of blades: 7  
 Protection class: IP54  
 Motor protection: thermal contact  
 Blades: Aluminium, uncoated  
 Rotor: Aluminium, uncoated  
 Conformity: ErP 2015, CE  
**ErP-data**  
 Efficiency  $\eta_{statA}$ : 36.4 %  
 Efficiency:  $N_{actual} = 40.2 / N_{target} = 40^{**}$   
 \* Rated data  
 \*\*ErP 2015

## Characteristic curve

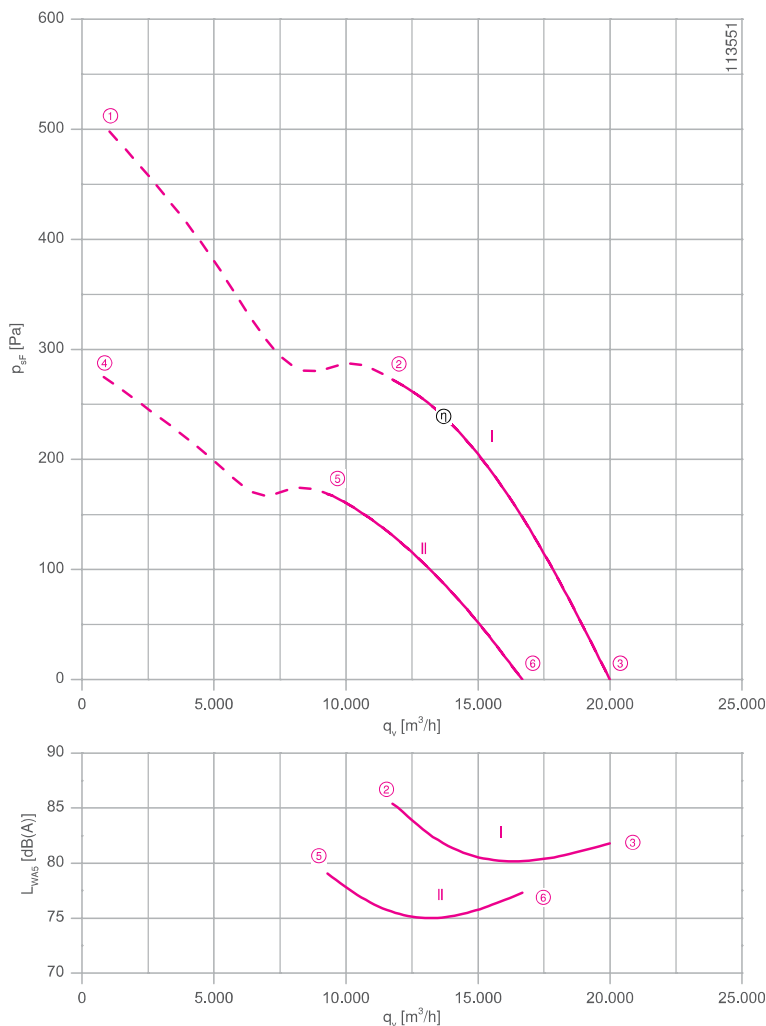

Measured in full bell mouth without guard grille in installation type A according to ISO 5801

Connection diagram Page 531  
1360-108XA

System components Page 430

## Dimensions mm



Design K - axial bolted, mounted for short bell mouth, guard grille pressure side

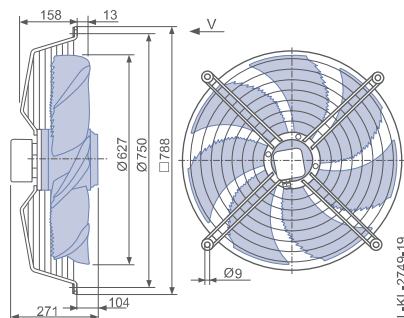

Design F - flange ring with two flanges, without guard grille

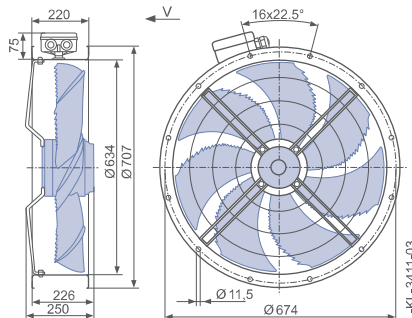

Design F - flange ring with two flanges, guard grille pressure side

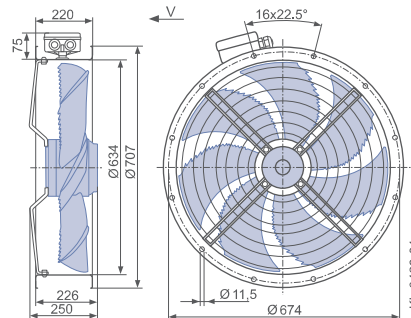



Performance data

Type	Connection	Characteristic curve	Voltage	Operating point	Current	Input power	Speed	Suction side sound power level $L_{WA5}$ dB(A)
			U V					
FN063-VD_6N_7P7	Δ	I	400	①	5.80	3300	1280	
			400*	②	5.00*	2600*	1330*	86
			400	③	4.20	2100	1380	82
	Y	II	400	④	3.30	2000	940	
			400*	⑤	3.00*	1750*	1050*	79
			400	⑥	2.50	1500	1140	77

\*rated data

Fan ordering information

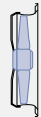
Airflow direction V				
Design	K (guard grille pressure side)	F (without guard grille)	F (guard grille pressure side)	Q (guard grille pressure side)
				
<b>Type</b>	FN063-VDK.6N.V7P7	FN063-VDF.6N.V7P7	FN063-VDF.6N.V7P7	FN063-VDQ.6N.V7P7
<b>Article no.</b>	169699	169701	169702	169700
<b>Weight kg</b>	31.10	35.10	35.90	41.20

Control technology

Frequency inverters Fcontrol 3~	Motor protection units 3~	Electronic voltage controllers 3~
		
Page 480	Page 518	Page 506

Design Q - square full bell mouth, guard grille pressure side

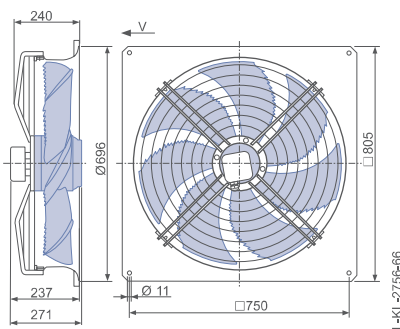

# FE2owlet

for three phase alternating current, 6-6 pole

FNO63-SD

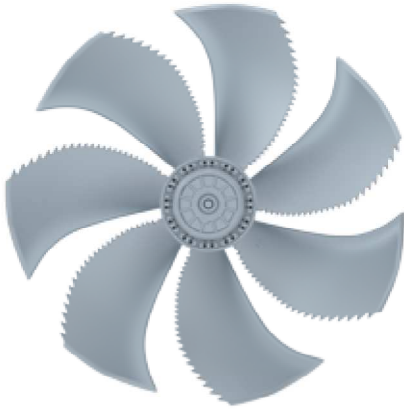

## Description

Motor technology: AC  
 Rated voltage  $U_N$ : 3- 400 V ( $\Delta/Y$ )  $\pm 10$  %  
 Rated frequency  $f_N$ : 50 Hz\* (60Hz data available)  
 Input power  $P_i$ : 0.62/0.44 kW\*  
 Rated current  $I_N$ : 1.25/0.72 A\*  
 Rated speed  $n_N$ : 900/ 720 min<sup>-1</sup>\*  
 Starting current  $I_s$ : 4.40 / 1.40 A  
 Current increase  $\Delta I$ : 15 %  
 Thermal class: THCL155\*  
 Min. permitted ambient temperature  $t_{R(min)}$ : -40 °C  
 Max. permitted ambient temperature  $t_{R(max)}$ : 70 °C  
 Electrical connection: Terminal box  
 Number of blades: 7  
 Protection class: IP54  
 Motor protection: thermal contact  
 Blades: Aluminium, uncoated  
 Rotor: Aluminium, uncoated  
 Conformity: ErP 2015, CE  
**ErP-data**  
 Efficiency  $\eta_{statA}$ : 33.8 %  
 Efficiency:  $N_{actual} = 41.6 / N_{target} = 40$ \*\*  
 \* Rated data  
 \*\*ErP 2015

## Characteristic curve

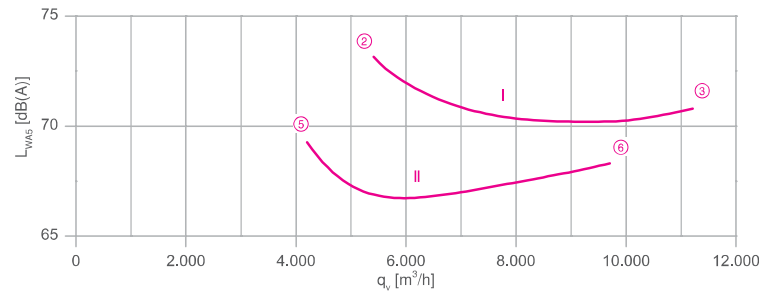
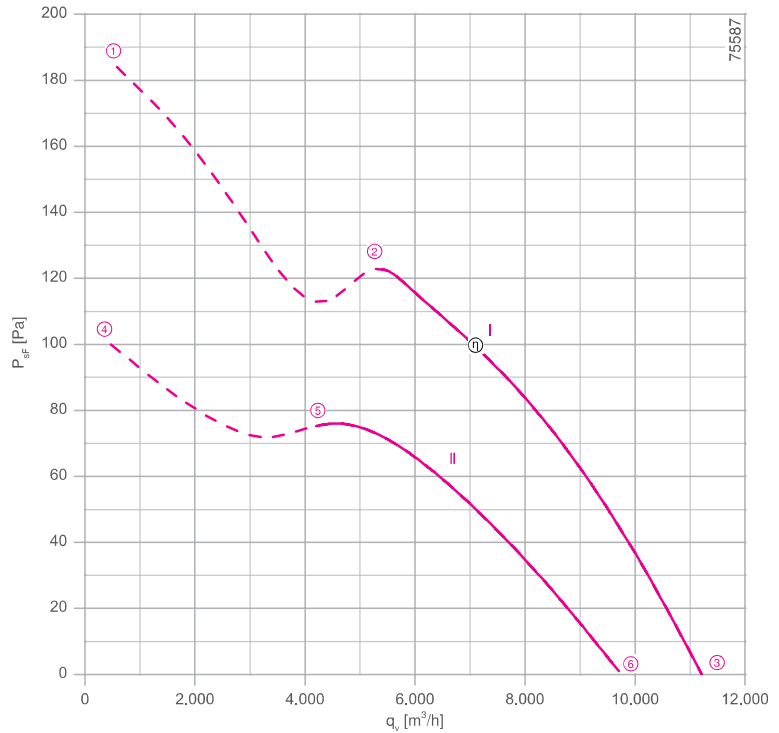

Measured in full bell mouth without guard grille in installation type A according to ISO 5801

Connection diagram Page 531  
 for airflow direction A 1360-108XB  
 for airflow direction V 1360-108XA

System components Page 430

## Dimensions mm

### Airflow direction A

Design Q - square full bell mouth, guard grille suction side

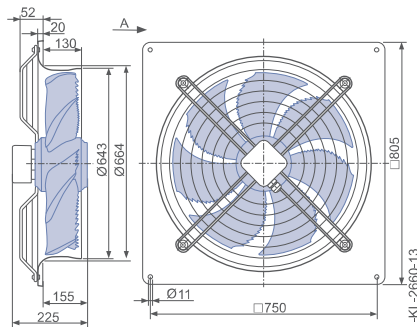

### Airflow direction V

Design K - axial bolted, mounted for short bell mouth, guard grille pressure side

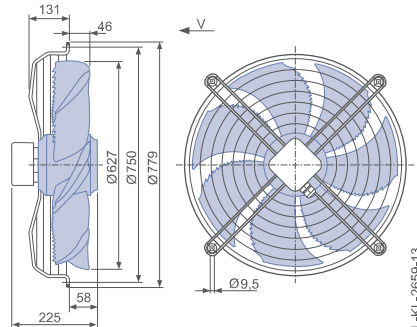

Design F - flange ring with two flanges, without guard grille

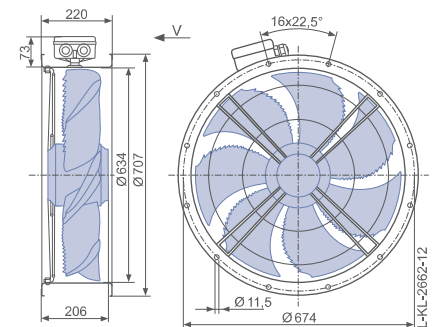

Performance data

Type	Connection	Characteristic curve	Voltage	Operating point	Current	Input power	Speed	Suction side sound power level $L_{WA5}$ dB(A)
			U V					
FN063-SD_4I_7P1	Δ	I	400	①	1.45	800	870	
			400*	②	1.25*	620*	900*	73
			400	③	1.05	440	940	71
	Y	II	400	④	0.86	520	640	
			400*	⑤	0.72*	440*	720*	69
			400	⑥	0.56	330	820	68

\*rated data

Fan ordering information

	Airflow direction A		Airflow direction V		
Design	Q (guard grille suction side)	K (guard grille pressure side)	F (without guard grille)	F (guard grille pressure side)	Q (guard grille pressure side)
Type	FN063-SDQ.4I.A7P1	FN063-SDK.4I.V7P1	FN063-SDF.4I.V7P1	FN063-SDF.4I.V7P1	FN063-SDQ.4I.V7P1
Article no.	141382	141384	141386	141387	141385
Weight kg	24.50	15.40	19.90	20.80	23.90

Control technology

Frequency inverters Fcontrol 3~	Motor protection units 3~	Electronic voltage controllers 3~
Page 480	Page 518	Page 506

Design F - flange ring with two flanges, guard grille pressure side

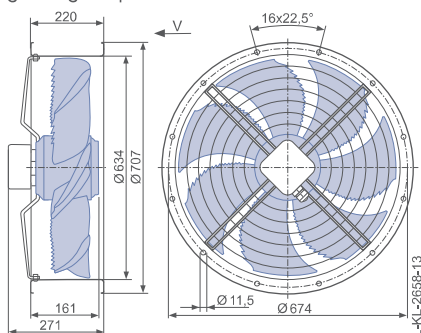

Design Q - square full bell mouth, guard grille pressure side

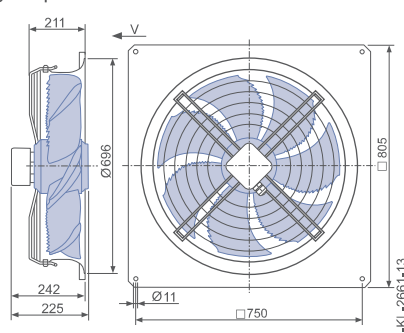

# FE2owlet

for three phase alternating current, 12-12 pole

FN063-ND

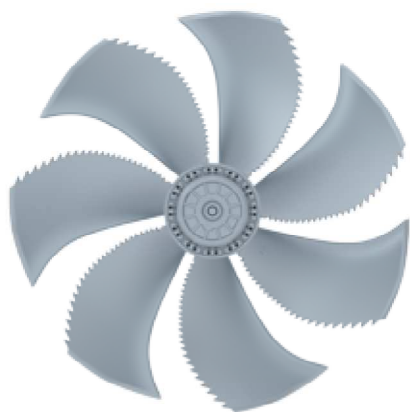

## Description

Motor technology: AC  
 Rated voltage  $U_N$ : 3- 400 V ( $\Delta/Y$ )  $\pm 10$  %\*  
 Rated frequency  $f_N$ : 50 Hz\* (60Hz data available)  
 Input power  $P_i$ : 130/70 W\*  
 Rated current  $I_N$ : 0.32/0.14 A\*  
 Rated speed  $n_N$ : 430/ 320 min<sup>-1</sup>\*  
 Starting current  $I_s$ : 2.40 / 1.05 A  
 Current increase  $\Delta I$ : 0 %  
 Thermal class: THCL155\*  
 Min. permitted ambient temperature  $t_{R(min)}$ : -40 °C  
 Max. permitted ambient temperature  $t_{R(max)}$ : 70 °C  
 Electrical connection: Terminal box  
 Number of blades: 7  
 Protection class: IP54  
 Motor protection: thermal contact  
 Blades: Aluminium, uncoated  
 Rotor: Aluminium, uncoated  
 Conformity: CE  
**ErP-data**  
 Not subject to the regulations of ErP directive ( $P_i < 125$  W)  
 \* Rated data

## Characteristic curve

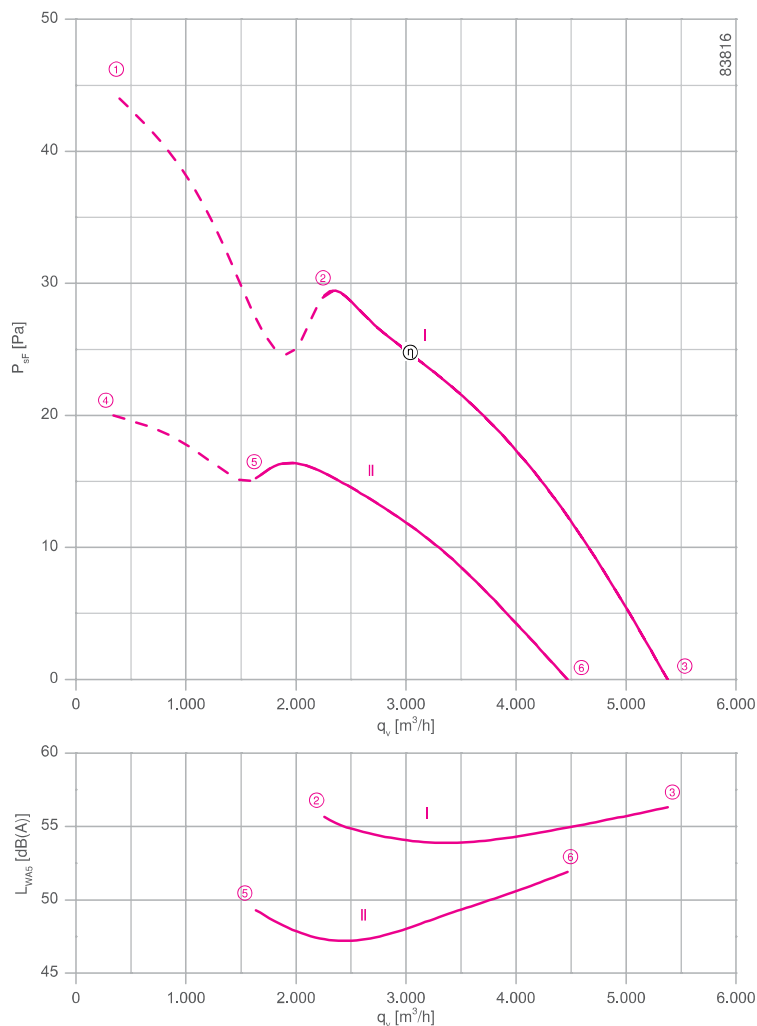

Measured in full bell mouth without guard grille in installation type A according to ISO 5801

Connection diagram Page 531  
 for airflow direction A 1360-108XB  
 for airflow direction V 1360-108XA

System components Page 430

## Dimensions mm

### Airflow direction A

Design Q - square full bell mouth, guard grille suction side

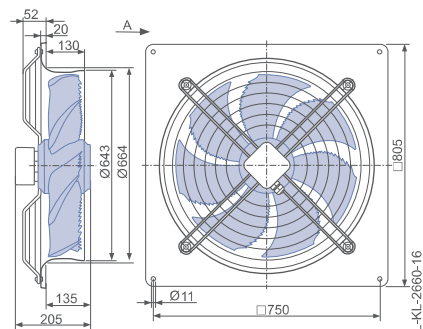

### Airflow direction V

Design K - axial bolted, mounted for short bell mouth, guard grille pressure side

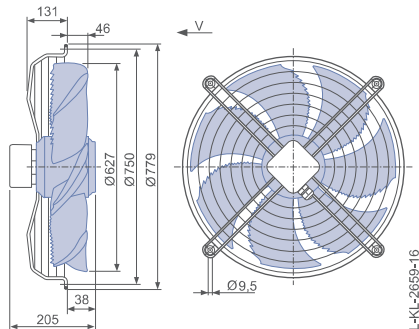

Design F - flange ring with two flanges, without guard grille

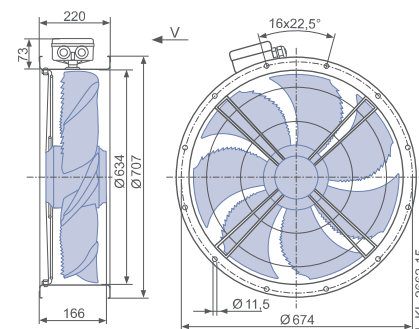

Performance data

Type	Connection	Characteristic curve	Voltage	Operating point	Current	Input power	Speed	Suction side sound power level
			U V		I A	P <sub>1</sub> W	n min <sup>-1</sup>	L <sub>WA5</sub> dB(A)
FN063-ND_4F_7P1	Δ	I	400	①	0.34	150	410	
			400*	②	0.32*	130*	430*	56
			400	③	0.31	110	460	56
	Y	II	400	④	0.14	75	290	
			400*	⑤	0.14*	70*	320*	49
			400	⑥	0.12	55	380	52

\*rated data

Fan ordering information

	Airflow direction A	Airflow direction V			
Design	Q (guard grille suction side)	K (guard grille pressure side)	F (without guard grille)	F (guard grille pressure side)	Q (guard grille pressure side)
Type	FN063-NDQ.4F.A7P1	FN063-NDK.4F.V7P1	FN063-NDF.4F.V7P1	FN063-NDF.4F.V7P1	FN063-NDQ.4F.V7P1
Article no.	141585	141587	141589	141590	141588
Weight kg	22.90	13.60	18.30	19.20	22.30

Control technology

Frequency inverters Fcontrol 3~	Motor protection units 3~	Electronic voltage controllers 3~
Page 480	Page 518	Page 506

Design F - flange ring with two flanges, guard grille pressure side

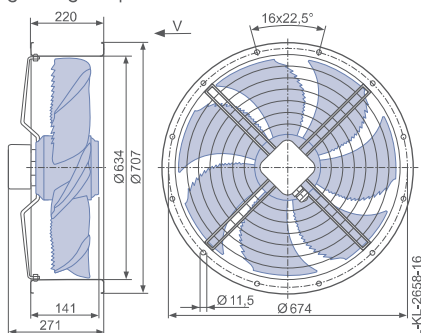

Design Q - square full bell mouth, guard grille pressure side

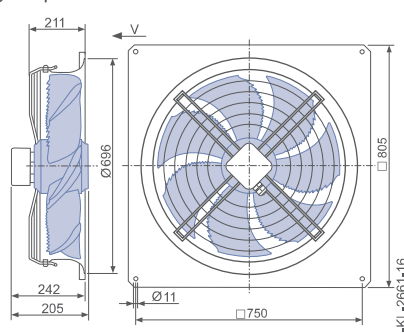

# FE2owlet

for three phase alternating current, 4-4 pole

FNO71-VD

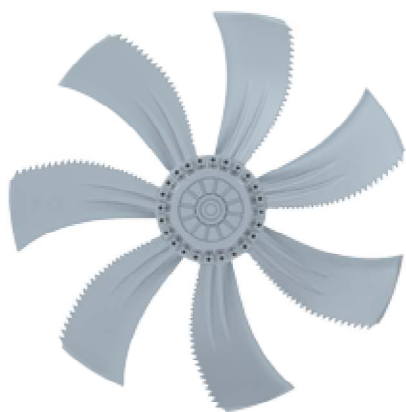

## Description

Motor technology: AC  
 Rated voltage  $U_N$ : 3- 400 V ( $\Delta/Y$ )  $\pm 10$  %\*  
 Rated frequency  $f_N$ : 50 Hz\*  
 Input power  $P_i$ : 2.60/1.70 kW\*  
 Rated current  $I_N$ : 4.80/2.90 A\*  
 Rated speed  $n_N$ : 1330/1050 min<sup>-1</sup>\*  
 Starting current  $I_s$ : 20.00 / 6.50 A  
 Current increase  $\Delta I$ : 5 %  
 Thermal class: THCL155\*  
 Min. permitted ambient temperature  $t_{R(min)}$ : -40 °C  
 Max. permitted ambient temperature  $t_{R(max)}$ : 60 °C  
 Electrical connection: Terminal box  
 Number of blades: 7  
 Protection class: IP54  
 Motor protection: thermal contact  
 Blades: Aluminium, uncoated  
 Rotor: Aluminium, uncoated  
 Conformity: ErP 2015, CE  
**ErP-data**  
 Efficiency  $\eta_{statA}$ : 37.9 %  
 Efficiency:  $N_{actual} = 41.7 / N_{target} = 40$ \*\*  
 \* Rated data  
 \*\*ErP 2015

## Characteristic curve

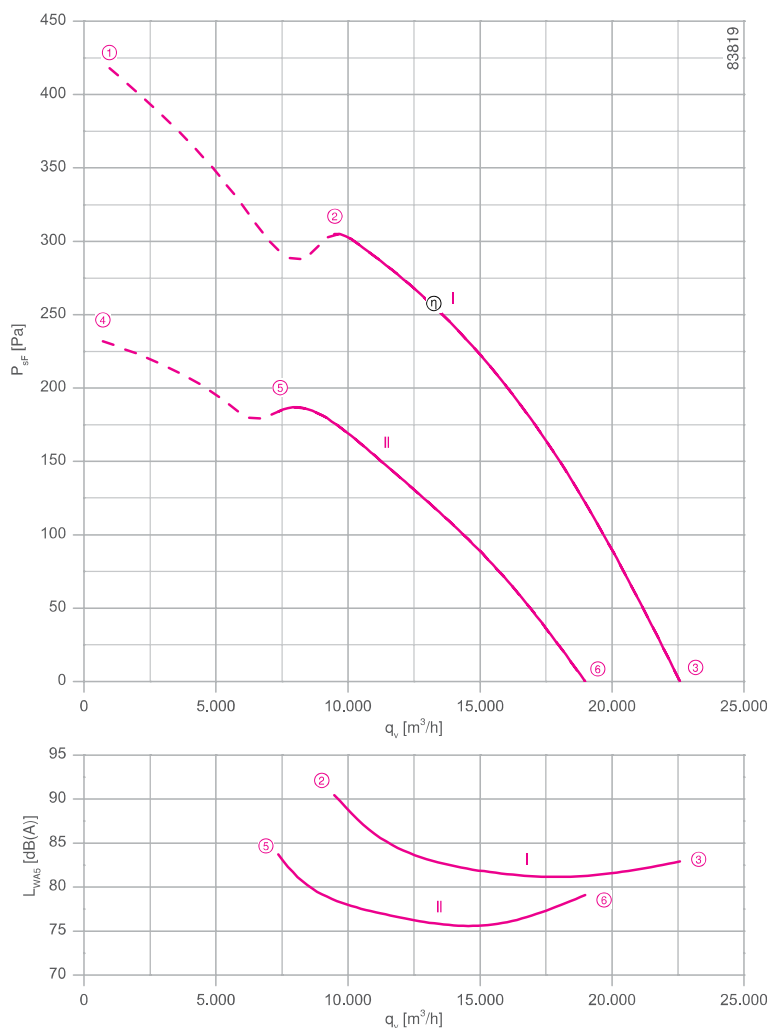

Measured in full bell mouth without guard grille in installation type A according to ISO 5801

Connection diagram Page 531  
 for airflow direction A 1360-108XB  
 for airflow direction V 1360-108XA

System components Page 430

## Dimensions mm

Airflow direction A

Design D - axial bolted, suspension for full bell mouth, guard grille suction side

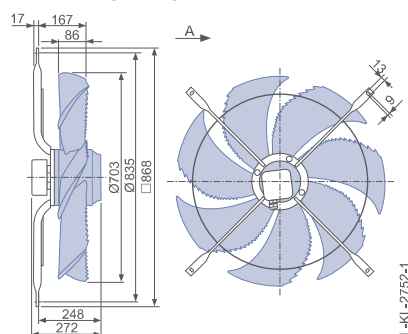

Design Q - square full bell mouth, without guard grille

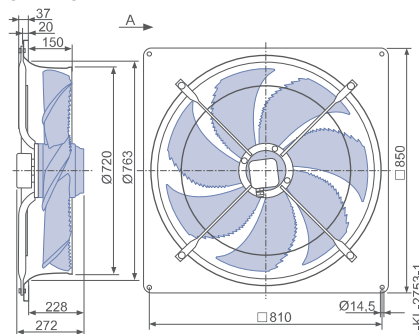

Airflow direction V

Design S - radially bolted, mounted for short bell mouth, guard grille pressure side

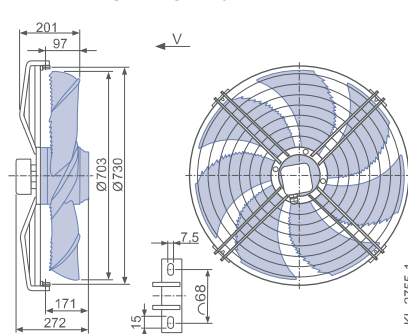

Performance data

Type	Connection	Characteristic curve	Voltage	Operating point	Current	Input power	Speed	Suction side sound power level $L_{WA5}$ dB(A)
			U V					
FN071-VD_6N_7P2	Δ	I	400	①	5.60	3100	1290	
			400*	②	4.80*	2600*	1330*	91
			400	③	3.90	1900	1390	83
	Y	II	400	④	3.20	1900	960	
			400*	⑤	2.90*	1700*	1050*	84
			400	⑥	2.30	1400	1170	79

\*rated data

Fan ordering information

	Airflow direction A		Airflow direction V		
Design	D (guard grille suction side)	Q (without guard grille)	S (guard grille pressure side)	I (guard grille pressure side)	Q (guard grille pressure side)
<b>Type</b>	FN071-VDD.6N.A7P2	FN071-VDQ.6N.A7P2	FN071-VDS.6N.V7P2	FN071-VDI.6N.V7P2	FN071-VDQ.6N.V7P2
<b>Article no.</b>	141760	141761	141782	155556	141777
<b>Weight kg</b>	25,90	36,90	28,90	29,10	39,60

Control technology

	Frequency inverters Fcontrol 3~	Motor protection units 3~	Electronic voltage controllers 3~
	Page 480	Page 518	Page 506

Design I - axial bolted, mounting for bell mouth flange, guard grille pressure side

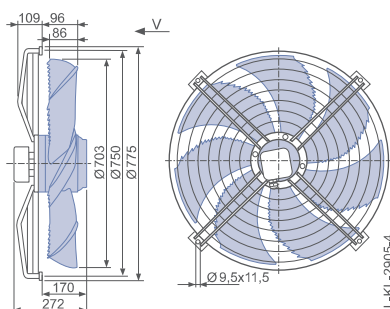

Design Q - square full bell mouth, guard grille pressure side

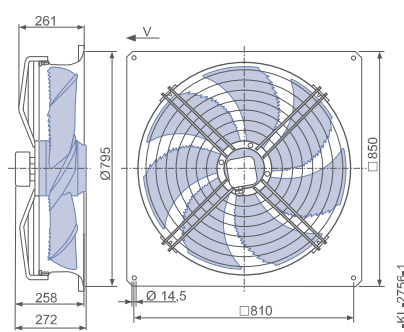



# FE2owlet

for three phase alternating current, 6-6 pole

FNO71-SD



## Description

Motor technology: AC  
 Rated voltage  $U_N$ : 3- 400 V ( $\Delta/Y$ )  $\pm 10$  %\*  
 Rated frequency  $f_N$ : 50 Hz\*  
 Input power  $P_i$ : 0.94/0.62 kW\*  
 Rated current  $I_N$ : 1.70/1.05 A\*  
 Rated speed  $n_N$ : 900/ 690 min<sup>-1</sup>\*  
 Starting current  $I_s$ : 6.00 / 1.80 A  
 Current increase  $\Delta I$ : 10 %  
 Thermal class: THCL155\*  
 Min. permitted ambient temperature  $t_{R(min)}$ : -40 °C  
 Max. permitted ambient temperature  $t_{R(max)}$ : 70 °C  
 Electrical connection: Terminal box  
 Number of blades: 7  
 Protection class: IP54  
 Motor protection: thermal contact  
 Blades: Aluminium, uncoated  
 Rotor: Aluminium, uncoated  
 Conformity: ErP 2015, CE  
**ErP-data**  
 Efficiency  $\eta_{statA}$ : 38.1 %  
 Efficiency:  $N_{actual} = 44.9 / N_{target} = 40$ \*\*  
 \* Rated data  
 \*\*ErP 2015

## Characteristic curve

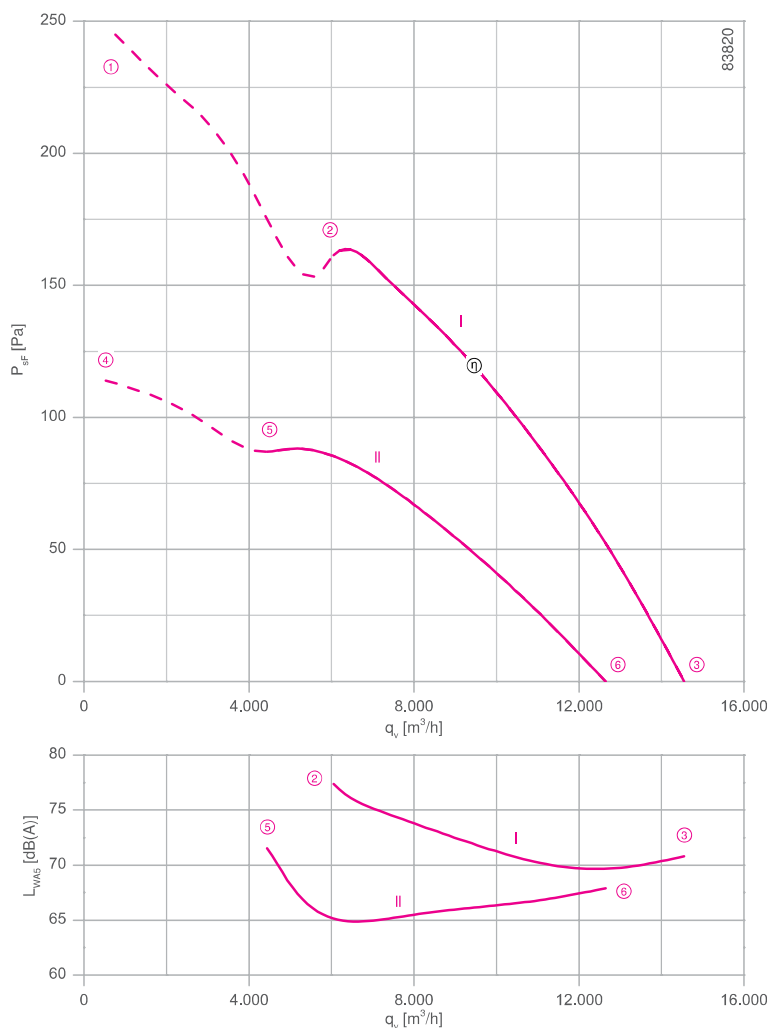

Measured in full bell mouth without guard grille in installation type A according to ISO 5801

Connection diagram Page 531  
 for airflow direction A 1360-108XB  
 for airflow direction V 1360-108XA

System components Page 430

## Dimensions mm

### Airflow direction A

Design D - axial bolted, suspension for full bell mouth, guard grille suction side

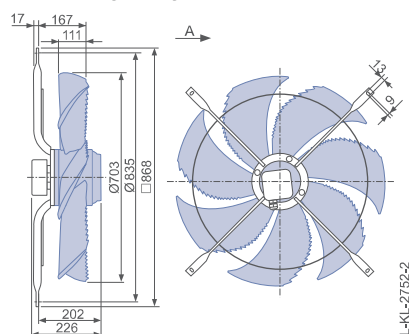

Design Q - square full bell mouth, without guard grille

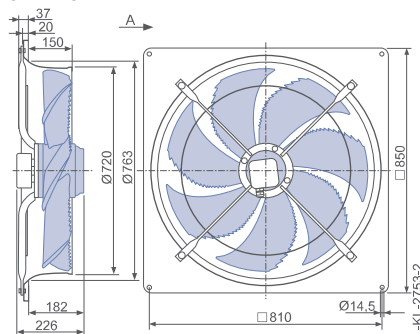

### Airflow direction V

Design S - radially bolted, mounted for short bell mouth, guard grille pressure side

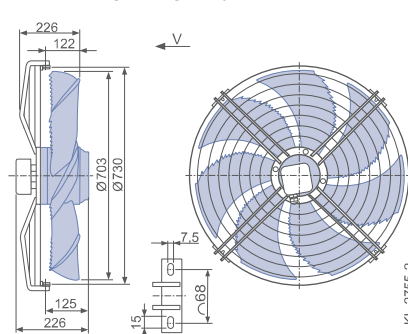

Performance data

Type	Connection	Characteristic curve	Voltage	Operating point	Current	Input power	Speed	Suction side sound power level $L_{WA5}$ dB(A)
			U V					
FN071-SD_6F_7P1	Δ	I	400	①	2.10	1200	850	
			400*	②	1.70*	940*	900*	78
			400	③	1.25	560	940	71
	Y	II	400	④	1.25	700	580	
			400*	⑤	1.05*	620*	690*	69
			400	⑥	0.77	450	820	68

\*rated data

Fan ordering information

	Airflow direction A		Airflow direction V		
Design	D (guard grille suction side)	Q (without guard grille)	S (guard grille pressure side)	I (guard grille pressure side)	Q (guard grille pressure side)
<b>Type</b>	<b>FN071-SDD.6F.A7P1</b>	<b>FN071-SDQ.6F.A7P1</b>	<b>FN071-SDS.6F.V7P1</b>	<b>FN071-SDI.6F.V7P1</b>	<b>FN071-SDQ.6F.V7P1</b>
<b>Article no.</b>	<b>141748</b>	<b>141749</b>	<b>141783</b>	<b>153791</b>	<b>141778</b>
<b>Weight kg</b>	20,50	31,50	23,40	23,40	34,30

Control technology

Frequency inverters Fcontrol 3~ 	Motor protection units 3~ 	Electronic voltage controllers 3~ 
Page 480	Page 518	Page 506

Design I - axial bolted, mounting for bell mouth flange, guard grille pressure side

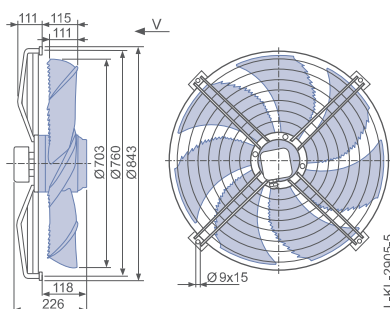

Design Q - square full bell mouth, guard grille pressure side

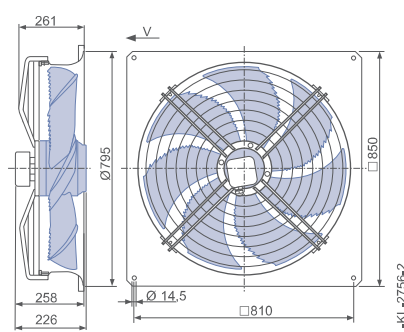

# FE2owlet

for three phase alternating current, 6-6 pole

FNO71-SD



## Description

Motor technology: AC  
 Rated voltage  $U_N$ : 3- 400 V ( $\Delta/Y$ )  $\pm 10$  %\*  
 Rated frequency  $f_N$ : 50 Hz\* (60Hz data available)  
 Input power  $P_i$ : 1.00/0.72 kW\*  
 Rated current  $I_N$ : 2.50/1.25 A\*  
 Rated speed  $n_N$ : 920/ 780 min<sup>-1</sup>\*  
 Starting current  $I_s$ : 9.50 / 3.00 A  
 Current increase  $\Delta I$ : 0 %  
 Thermal class: THCL155\*  
 Min. permitted ambient temperature  $t_{R(min)}$ : -40 °C  
 Max. permitted ambient temperature  $t_{R(max)}$ : 70 °C  
 Electrical connection: Terminal box  
 Number of blades: 7  
 Protection class: IP54  
 Motor protection: thermal contact  
 Blades: Aluminium, uncoated  
 Rotor: Aluminium, uncoated  
 Conformity: ErP 2015, CE  
**ErP-data**  
 Efficiency  $\eta_{statA}$ : 37.4 %  
 Efficiency:  $N_{actual} = 44.0 / N_{target} = 40$ \*\*  
 \* Rated data  
 \*\*ErP 2015

## Characteristic curve

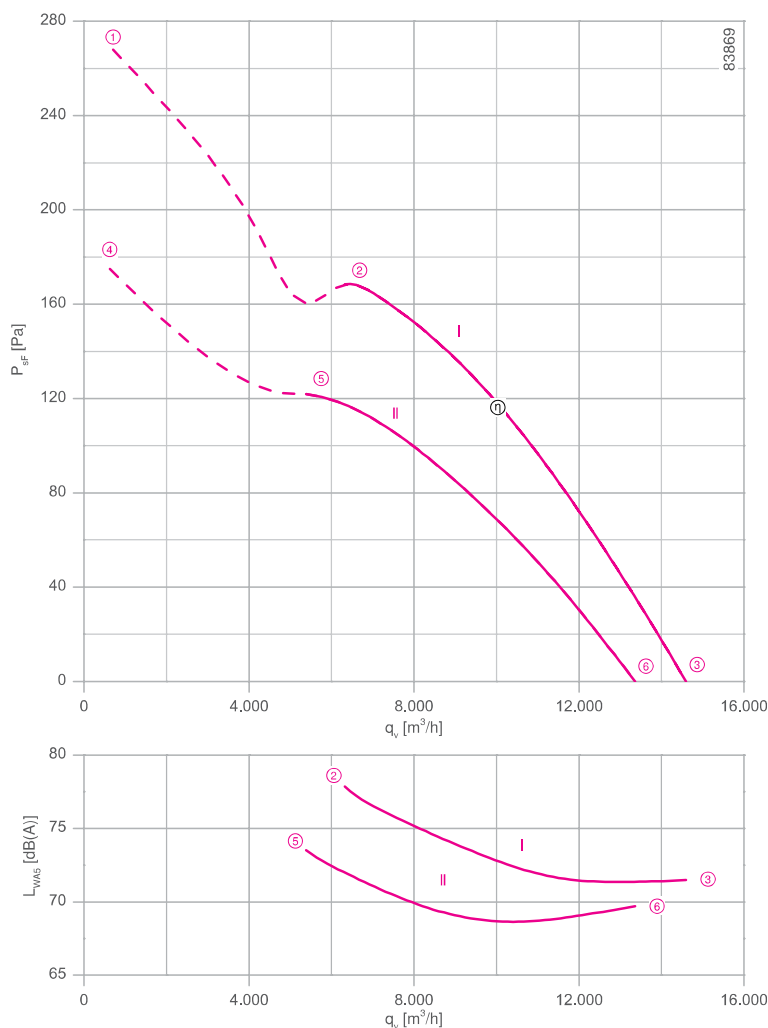

Measured in full bell mouth without guard grille in installation type A according to ISO 5801

Connection diagram Page 531  
 for airflow direction A 1360-108XB  
 for airflow direction V 1360-108XA

System components Page 430

## Dimensions mm

Airflow direction A

Design D - axial bolted, suspension for full bell mouth, guard grille suction side

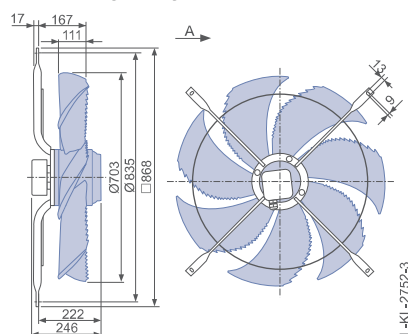

Design Q - square full bell mouth, without guard grille

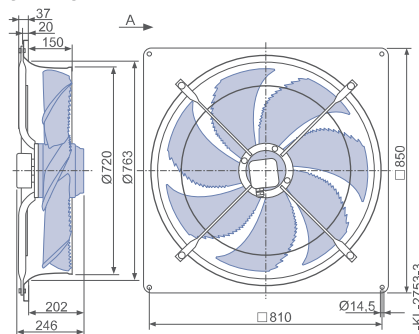

Airflow direction V

Design S - radially bolted, mounted for short bell mouth, guard grille pressure side

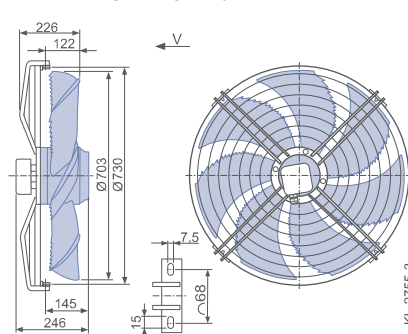





Performance data

Type	Connection	Characteristic curve	Voltage	Operating point	Current	Input power	Speed	Suction side sound power level $L_{WA5}$ dB(A)
			U V					
FN071-SD_6K_7P1	Δ	I	400	①	2.70	1300	880	
			400*	②	2.50*	1000*	920*	78
			400	③	2.20	640	950	72
	Y	II	400	④	1.45	860	710	
			400*	⑤	1.25*	700*	780*	74
			400	⑥	0.92	460	870	70

\*rated data

Fan ordering information

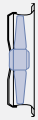
	Airflow direction A		Airflow direction V		
Design	D (guard grille suction side)	Q (without guard grille)	S (guard grille pressure side)	I (guard grille pressure side)	Q (guard grille pressure side)
					
<b>Type</b>	<b>FN071-SDD.6K.A7P1</b>	<b>FN071-SDQ.6K.A7P1</b>	<b>FN071-SDS.6K.V7P1</b>	<b>FN071-SDI.6K.V7P1</b>	<b>FN071-SDQ.6K.V7P1</b>
<b>Article no.</b>	<b>141751</b>	<b>141752</b>	<b>141784</b>	<b>156935</b>	<b>141779</b>
<b>Weight kg</b>	24,10	35,10	27,00	27,20	37,90

Control technology

Frequency inverters Fcontrol 3~  Page 480	Motor protection units 3~  Page 518	Electronic voltage controllers 3~  Page 506
--	--	--

Design I - axial bolted, mounting for bell mouth flange, guard grille pressure side

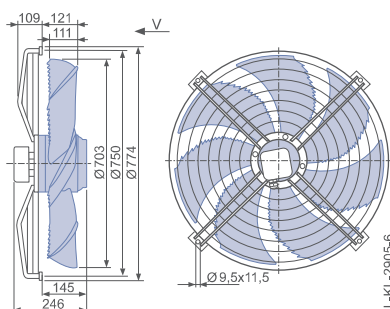

Design Q - square full bell mouth, guard grille pressure side

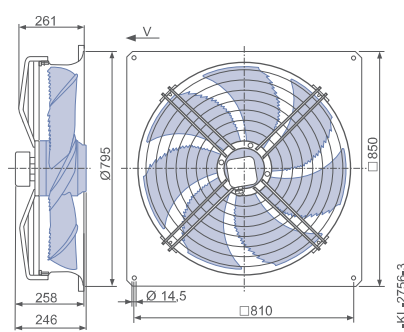

# FE2owlet

for three phase alternating current, 8-8 pole

FNO71-AD



## Description

Motor technology: AC  
 Rated voltage  $U_N$ : 3- 400 V ( $\Delta/Y$ )  $\pm 10$  %\*  
 Rated frequency  $f_N$ : 50 Hz\* (60Hz data available)  
 Input power  $P_i$ : 0.46/0.31 kW\*  
 Rated current  $I_N$ : 1.10/0.60 A\*  
 Rated speed  $n_N$ : 680/540 min<sup>-1</sup>\*  
 Starting current  $I_s$ : 3.20 / 0.95 A  
 Current increase  $\Delta I$ : 0 %  
 Thermal class: THCL155\*  
 Min. permitted ambient temperature  $t_{R(min)}$ : -40 °C  
 Max. permitted ambient temperature  $t_{R(max)}$ : 70 °C  
 Electrical connection: Terminal box  
 Number of blades: 7  
 Protection class: IP54  
 Motor protection: thermal contact  
 Blades: Aluminium, uncoated  
 Rotor: Aluminium, uncoated  
 Conformity: ErP 2015, CE  
**ErP-data**  
 Efficiency  $\eta_{statA}$ : 33.4 %  
 Efficiency:  $N_{actual} = 42.1 / N_{target} = 40$ \*\*  
 \* Rated data  
 \*\*ErP 2015

## Characteristic curve

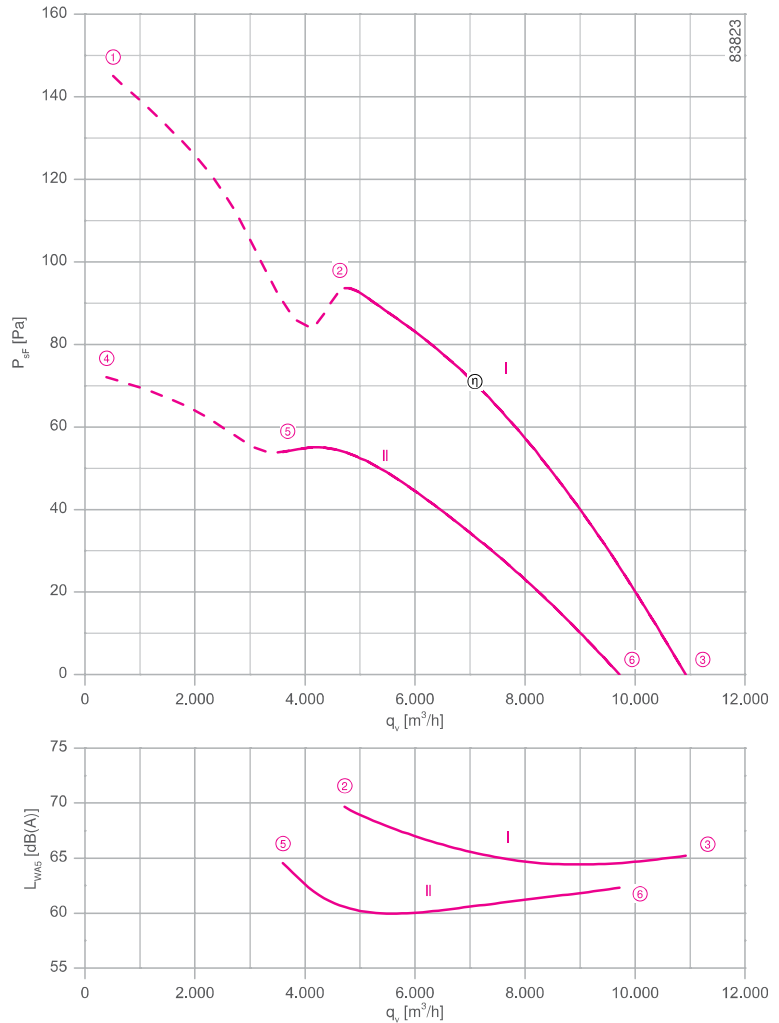

Measured in full bell mouth without guard grille in installation type A according to ISO 5801

Connection diagram Page 531  
 for airflow direction A 1360-108XB  
 for airflow direction V 1360-108XA

System components Page 430

## Dimensions mm

Airflow direction A

Design D - axial bolted, suspension for full bell mouth, guard grille suction side

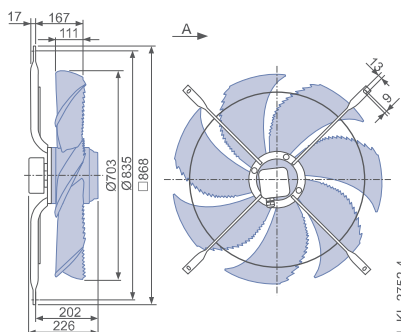

Design Q - square full bell mouth, without guard grille

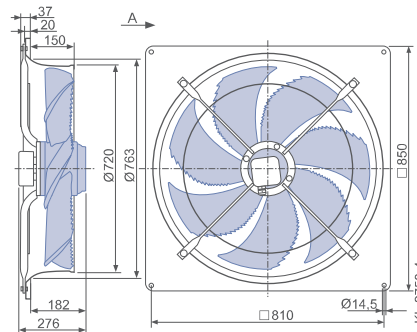

Airflow direction V

Design S - radially bolted, mounted for short bell mouth, guard grille pressure side

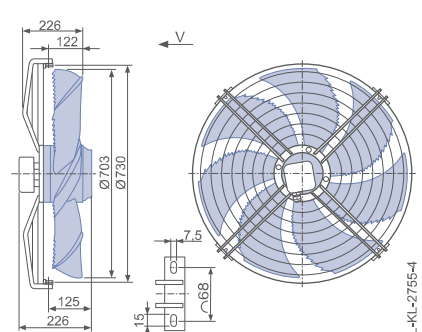

Performance data

Type	Connection	Characteristic curve	Voltage	Operating point	Current	Input power	Speed	Suction side sound power level $L_{WA5}$ dB(A)
			U V					
FN071-AD_6F_7P1	Δ	I	400	①	1.25	580	650	
			400*	②	1.10*	460*	680*	70
			400	③	0.96	300	710	65
	Y	II	400	④	0.70	350	460	
			400*	⑤	0.60*	310*	540*	65
			400	⑥	0.44	210	640	62

\*rated data

Fan ordering information

	Airflow direction A		Airflow direction V		
Design	D (guard grille suction side)	Q (without guard grille)	S (guard grille pressure side)	I (guard grille pressure side)	Q (guard grille pressure side)
<b>Type</b>	FN071-ADD.6F.A7P1	FN071-ADQ.6F.A7P1	FN071-ADS.6F.V7P1	FN071-ADI.6F.V7P1	FN071-ADQ.6F.V7P1
<b>Article no.</b>	141754	141755	141785	141800	141780
<b>Weight kg</b>	20,50	31,50	23,40	23,10	34,30

Control technology

	Frequency inverters Fcontrol 3~	Motor protection units 3~	Electronic voltage controllers 3~
	Page 480	Page 518	Page 506

Design I - axial bolted, mounting for bell mouth flange, guard grille pressure side

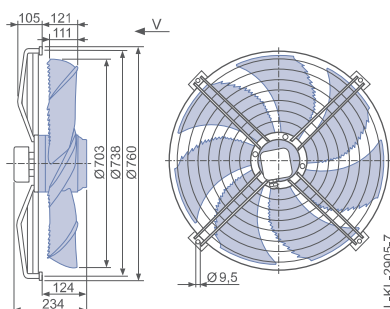

Design Q - square full bell mouth, guard grille pressure side

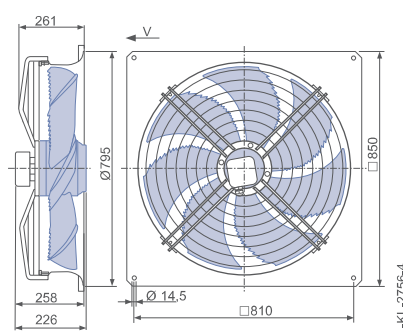

# FE2owlet

for three phase alternating current, 12-12 pole

FNO71-ND

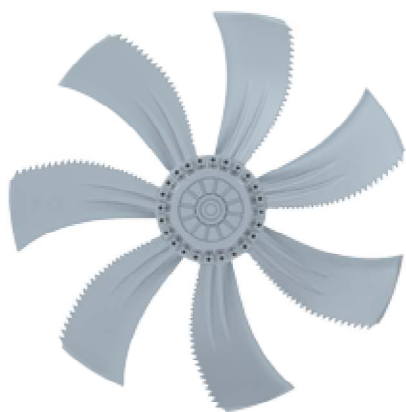

## Description

Motor technology: AC  
 Rated voltage  $U_N$ : 3- 400 V ( $\Delta/Y$ )  $\pm 10$  %\*  
 Rated frequency  $f_N$ : 50 Hz\*  
 Input power  $P_i$ : 140/85 W\*  
 Rated current  $I_N$ : 0.37/0.175 A\*  
 Rated speed  $n_N$ : 440/ 350 min<sup>-1</sup>\*  
 Current increase  $\Delta I$ : 0 %  
 Thermal class: THCL155\*  
 Min. permitted ambient temperature  $t_{R(min)}$ : -40 °C  
 Max. permitted ambient temperature  $t_{R(max)}$ : 70 °C  
 Electrical connection: Terminal box  
 Number of blades: 7  
 Protection class: IP54  
 Motor protection: thermal contact  
 Blades: Aluminium, uncoated  
 Rotor: Aluminium, uncoated  
 Conformity: ErP 2015, CE  
**ErP-data**  
 Efficiency  $\eta_{statA}$ : 28.4 %  
 Efficiency:  $N_{actual} = 40.3 / N_{target} = 40$ \*\*  
 Frequency inverter required  
 \* Rated data  
 \*\*ErP 2015

## Characteristic curve

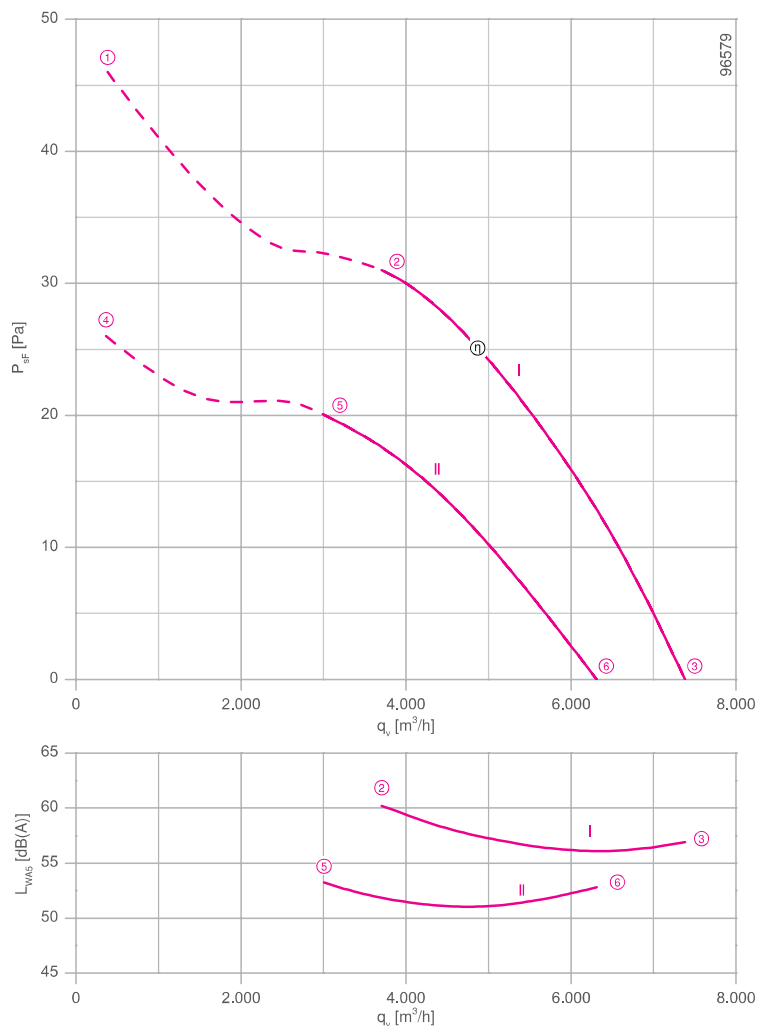

Measured in full bell mouth without guard grille in installation type A according to ISO 5801

Connection diagram Page 531  
 for airflow direction A 1360-108XB  
 for airflow direction V 1360-108XA

System components Page 430

## Dimensions mm

Airflow direction A

Design D - axial bolted, suspension for full bell mouth, guard grille suction side

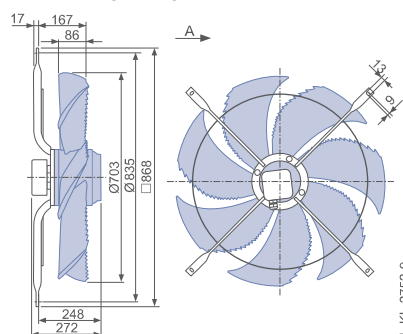

Design Q - square full bell mouth, without guard grille

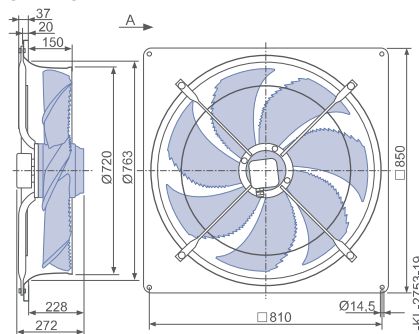

Airflow direction V

Design K - axial bolted, mounted for short bell mouth, guard grille pressure side

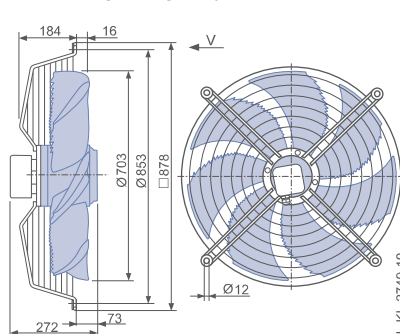





Performance data

Type	Connection	Characteristic curve	Voltage	Operating point	Current	Input power	Speed	Suction side sound power level $L_{WA5}$ dB(A)
			U V					
FN071-ND_6N_7P2	Δ	I	400	①	0.40	160	430	
			400*	②	0.37*	140*	440*	60
			400	③	0.35	110	460	57
	Y	II	400	④	0.19	95	320	
			400*	⑤	0.17*	85*	350*	53
			400	⑥	0.15	70	390	53

\*rated data

Fan ordering information

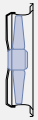
	Airflow direction A			Airflow direction V		
Design	D (guard grille suction side)	Q (without guard grille)	K (guard grille pressure side)	S (guard grille pressure side)	I (guard grille pressure side)	Q (guard grille pressure side)
						
<b>Type</b>	FN071-NDD.6N.A7P2	FN071-NDQ.6N.A7P2	FN071-NDK.6N.V7P2	FN071-NDS.6N.V7P2	FN071-NDI.6N.V7P2	FN071-NDQ.6N.V7P2
<b>Article no.</b>	160060	160061	160063	160065	160066	160064
<b>Weight kg</b>	25,90	36,90	29,60	28,90	23,00	39,60

Control technology

Frequency inverters Fcontrol 3~  Page 480	Motor protection units 3~  Page 518	Electronic voltage controllers 3~  Page 506
--	--	--

Design S - radially bolted, mounted for short bell mouth, guard grille pressure side

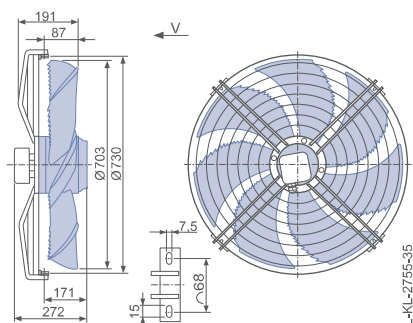

Design I - axial bolted, mounting for bell mouth flange, guard grille pressure side

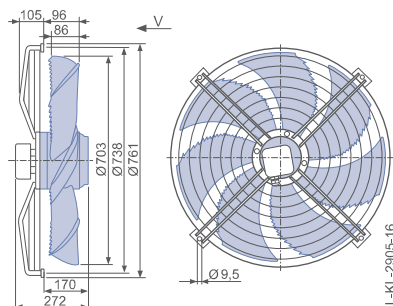

Design Q - square full bell mouth, guard grille pressure side

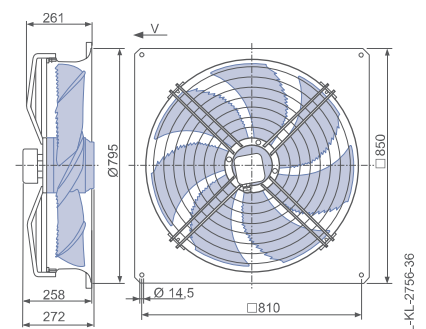



# FE2owlet

for three phase alternating current, 4-4 pole

FN080-VD



## Description

Motor technology: AC  
 Rated voltage  $U_N$ : 3- 400 V ( $\Delta/Y$ )  $\pm 10$  %\*  
 Rated frequency  $f_N$ : 50 Hz\*  
 Input power  $P_i$ : 3.90/2.60 kW\*  
 Rated current  $I_N$ : 6.80/4.20 A\*  
 Rated speed  $n_N$ : 1310/1050 min<sup>-1</sup>\*  
 Starting current  $I_s$ : 32.00 / 10.00 A  
 Current increase  $\Delta I$ : 5 %  
 Thermal class: THCL155\*  
 Min. permitted ambient temperature  $t_{R(min)}$ : -40 °C  
 Max. permitted ambient temperature  $t_{R(max)}$ : 70 °C  
 Electrical connection: Terminal box  
 Number of blades: 5  
 Protection class: IP54  
 Motor protection: thermal contact  
 Blades: Aluminium, uncoated  
 Rotor: Aluminium, uncoated  
 Conformity: ErP 2015, CE  
**ErP-data**  
 Efficiency  $\eta_{statA}$ : 40.4 %  
 Efficiency:  $N_{actual} = 43.2 / N_{target} = 40$ \*\*  
 \* Rated data  
 \*\*ErP 2015

## Characteristic curve

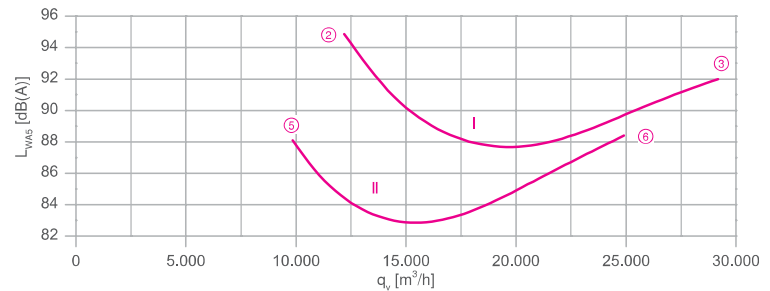
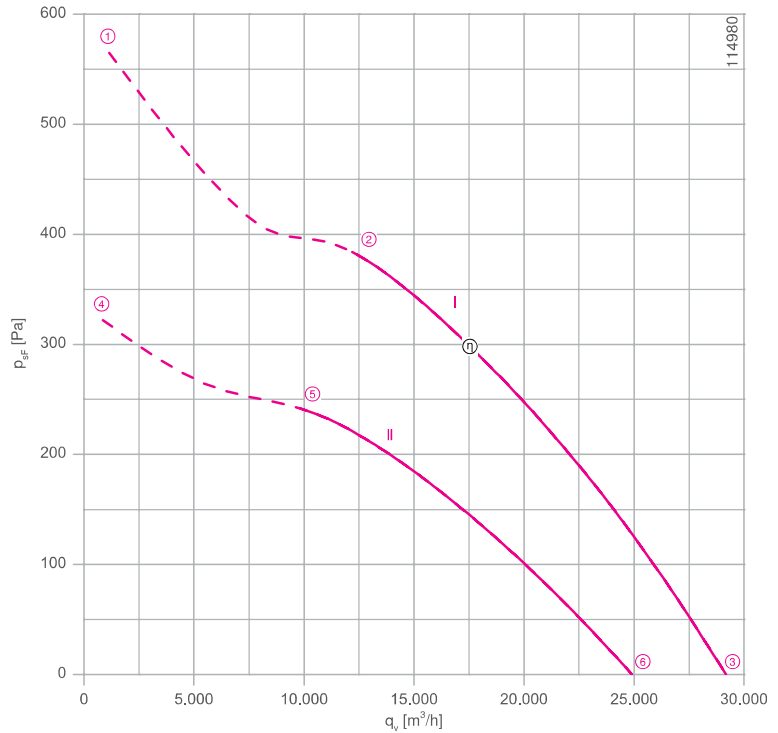

Measured in full bell mouth without guard grille in installation type A according to ISO 5801

Connection diagram Page 531  
 for airflow direction A 1360-108XB  
 for airflow direction V 1360-108XA

System components Page 430

## Dimensions mm

Airflow direction A

Design Q - square full bell mouth, guard grille suction side

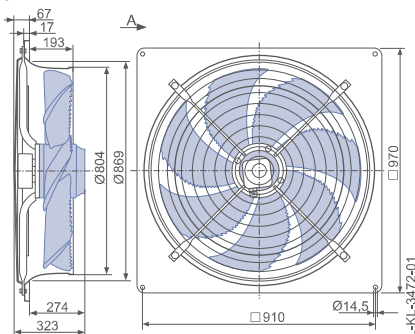

Airflow direction V

Design S - radially bolted, mounted for short bell mouth, guard grille pressure side

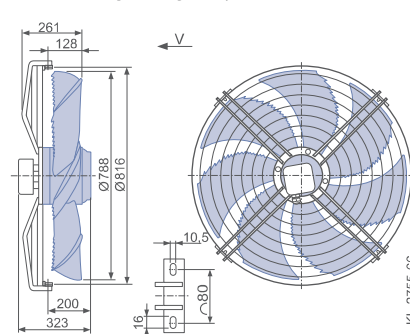

Design Q - square full bell mouth, guard grille pressure side

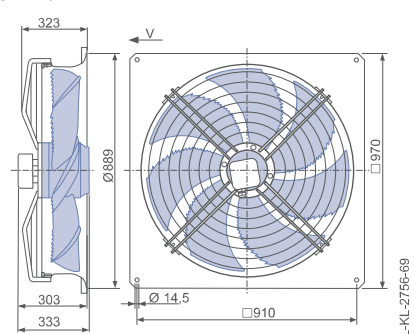



Performance data

Type	Connection	Characteristic curve	Voltage	Operating point	Current	Input power	Speed	Suction side sound power level $L_{WA5}$ dB(A)
			U V					
FN080-VD_7Q_5P7	Δ	I	400	①	8.40	5000	1240	
			400*	②	6.80*	3900*	1310*	95
			400	③	5.20	2700	1380	92
	Y	II	400	④	5.00	3000	930	
			400*	⑤	4.20*	2600*	1050*	88
			400	⑥	3.20	2000	1180	88

\*rated data

Fan ordering information

	Airflow direction A	Airflow direction V	
Design	Q (guard grille suction side)	S (guard grille pressure side)	Q (guard grille pressure side)
			
Type	FN080-VDQ.7Q.A5P7	FN080-VDS.7Q.V5P7	FN080-VDQ.7Q.V5P7
Article no.	171318	171315	171314
Weight kg	65.60	50.90	65.20

Control technology

Frequency inverters Fcontrol 3~	Motor protection units 3~	Electronic voltage controllers 3~
		
Page 480	Page 518	Page 506

# FE2owlet

for three phase alternating current, 6-6 pole

FNO80-SD



## Description

Motor technology: AC  
 Rated voltage  $U_N$ : 3- 400 V ( $\Delta/Y$ )  $\pm 10\%$ \*  
 Rated frequency  $f_N$ : 50 Hz\*  
 Motor input power  $P_1$ : 1.80/1.15 kW\*  
 Rated current  $I_N$ : 3.90/2.20 A\*  
 Rated speed  $n_N$ : 900/ 700  $\text{min}^{-1}$ \*  
 Starting current  $I_s$ : 13.00 A / 3.80 A  
 Current increase  $\Delta I$ : 5 %  
 Thermal class: THCL155\*  
 Min. permitted conveyor temperature  $t_{R(\text{min})}$ : -40 °C  
 Max. permitted conveyor temperature  $t_{R(\text{max})}$ : 65 °C  
 Electrical connection: Terminal box  
 Number of blades: 7  
 Protection class: IP54  
 Motor protection: Thermal contact  
 Blades: Aluminium, uncoated  
 Rotor: Aluminium, uncoated  
 Conformity: ErP 2015, CE  
**ErP Data**  
 Efficiency  $\eta_{\text{statA}}$ : 36.8 %  
 Efficiency:  $N_{\text{actual}} = 41.5 / N_{\text{target}} = 40$ \*\*  
 \* Rated data  
 \*\*ErP 2015

## Characteristic curve

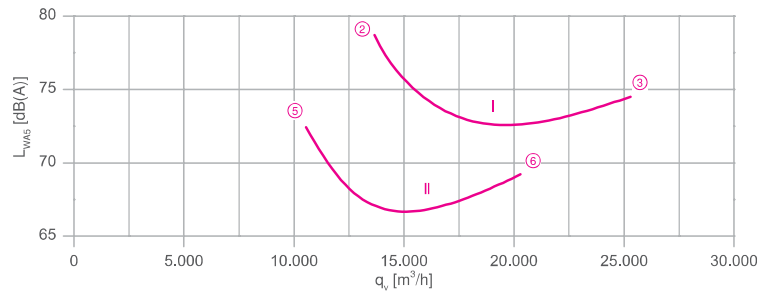
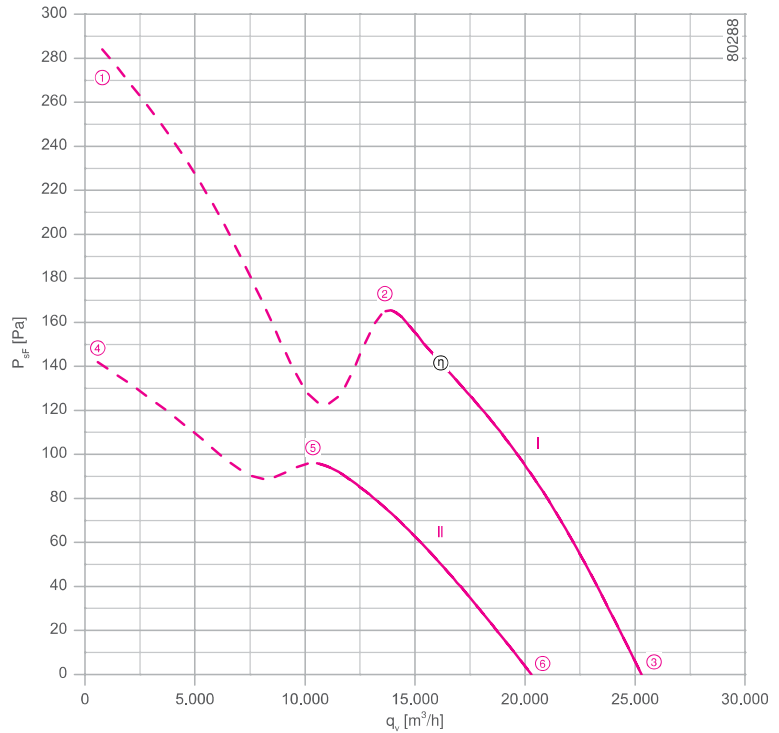

Measured in full bell mouth without guard grille in installation type A according to ISO 5801

Connection diagram Page 531  
1360-108XA

System components Page 430

## Dimensions mm

Airflow direction V

Design S - radially bolted, mounted for short bell mouth, guard grille pressure side

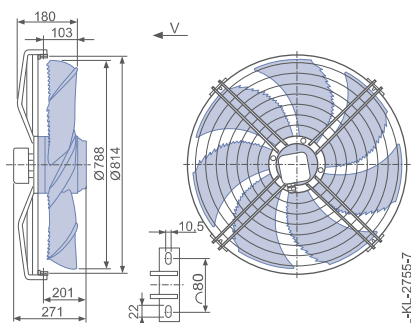

Design I - axial bolted, mounting for bell mouth flange, guard grille pressure side

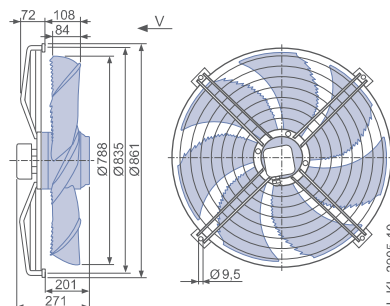

Design Q - square full bell mouth, guard grille pressure side

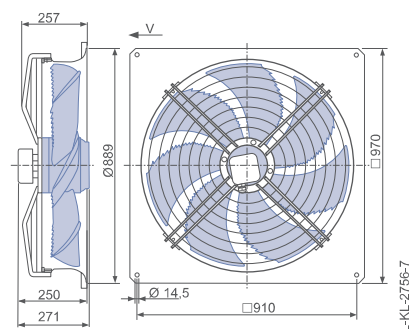

### Performance data

Type	Connection	Characteristic curve	Voltage	Operating point	Current	Input power	Speed	Suction side sound power level $L_{WA5}$ dB(A)
			U V					
FN080-SD_6N_7	Δ	I	400	①	4.80	2400	860	
			400*	②	3.90*	1800*	900*	79
			400	③	3.60	1550	920	75
	Y	II	400	④	2.50	1300	600	
			400*	⑤	2.20*	1150*	700*	73
			400	⑥	2.00	1050	740	69

\*rated data

### Fan ordering information

Airflow direction V			
Design	S (guard grille pressure side)	I (guard grille pressure side)	Q (guard grille pressure side)
			
<b>Type</b>	<b>FN080-SDS.6N.V7</b>	<b>FN080-SDI.6N.V7</b>	<b>FN080-SDQ.6N.V7</b>
<b>Article no.</b>	<b>138757</b>	<b>153512</b>	<b>138758</b>
<b>Weight kg</b>	36.50	36.10	50.90

### Control technology

Frequency inverters Fcontrol 3~	Motor protection units 3~	Electronic voltage controllers 3~
		
Page 480	Page 518	Page 506

# FE2owlet

for three phase alternating current, 6-6 pole

FN080-SD



## Description

Motor technology: AC  
 Rated voltage  $U_N$ : 3- 400 V ( $\Delta/Y$ )  $\pm 10$  %\*  
 Rated frequency  $f_N$ : 50 Hz\*  
 Input power  $P_i$ : 1.90/1.10 kW\*  
 Rated current  $I_N$ : 3.90/2.00 A\*  
 Rated speed  $n_N$ : 870/ 630  $\text{min}^{-1}$ \*  
 Starting current  $I_s$ : 11.00 / 3.40 A  
 Current increase  $\Delta I$ : 0 %  
 Thermal class: THCL155\*  
 Min. permitted ambient temperature  $t_{R(\text{min})}$ : -40 °C  
 Max. permitted ambient temperature  $t_{R(\text{max})}$ : 60 °C  
 Electrical connection: Terminal box  
 Number of blades: 7  
 Protection class: IP54  
 Motor protection: thermal contact  
 Blades: Aluminium, uncoated  
 Rotor: Aluminium, uncoated  
 Conformity: ErP 2015, CE  
**ErP-data**  
 Efficiency  $\eta_{\text{statA}}$ : 36.3 %  
 Efficiency:  $N_{\text{actual}} = 41.0 / N_{\text{target}} = 40$ \*\*  
 \* Rated data  
 \*\*ErP 2015

## Characteristic curve

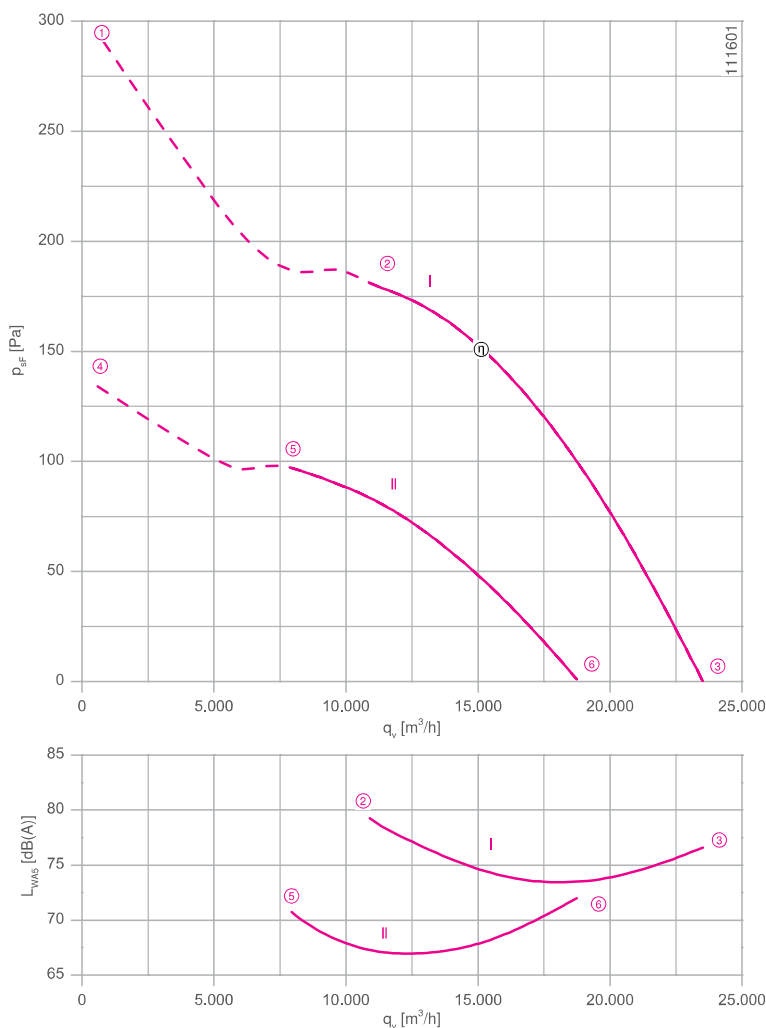

Measured in full bell mouth without guard grille in installation type A according to ISO 5801

Connection diagram Page 531  
1360-108XA

System components Page 430

## Dimensions mm

← Airflow direction V

Design K - axial bolted, mounted for short bell mouth, guard grille pressure side

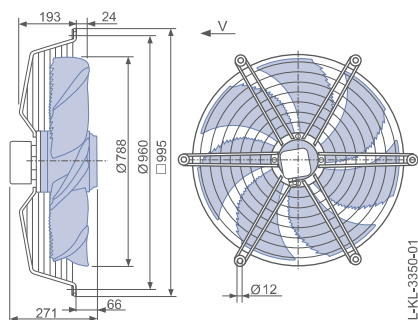

Design S - radially bolted, mounted for short bell mouth, guard grille pressure side

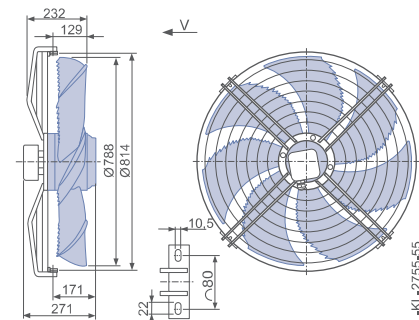

Design I - axial bolted, mounting for bell mouth flange, guard grille pressure side

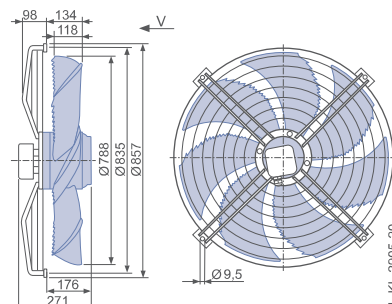



Performance data

Type	Connection	Characteristic curve	Voltage	Operating point	Current	Input power	Speed	Suction side sound power level $L_{WA5}$ dB(A)
			U V					
FN080-SD_.6N.V7P5	Δ	I	400	①	4.60	2400	810	
			400*	②	3.90*	1900*	870*	80
			400	③	3.10	1350	920	77
	Y	II	400	④	2.20	1200	550	
			400*	⑤	2.00*	1100*	630*	71
			400	⑥	1.70	900	740	72

\*rated data

Fan ordering information

Airflow direction V

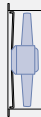
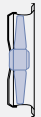
Design	K (guard grille pressure side)	S (guard grille pressure side)	I (guard grille pressure side)	F (without guard grille)	Q (guard grille pressure side)
					
<b>Type</b>	<b>FN080-SDK.6N.V7P5</b>	<b>FN080-SDS.6N.V7P5</b>	<b>FN080-SDI.6N.V7P5</b>	<b>FN080-SDF.6N.V7P5</b>	<b>FN080-SDQ.6N.V7P5</b>
<b>Article no.</b>	<b>168788</b>	<b>168787</b>	<b>168785</b>	<b>168789</b>	<b>168786</b>
<b>Weight kg</b>	37.90	33.70	33.60	45.80	42.60

Control technology

Frequency inverters Fcontrol 3~	Motor protection units 3~	Electronic voltage controllers 3~
		
Page 480	Page 518	Page 506

Design F - flange ring with two flanges, without guard grille

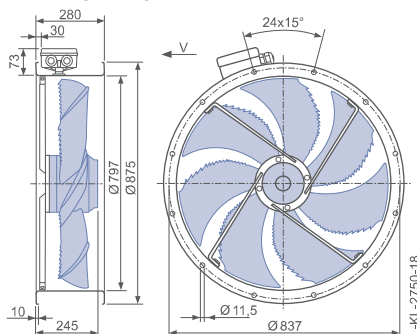

Design Q - square full bell mouth, guard grille pressure side

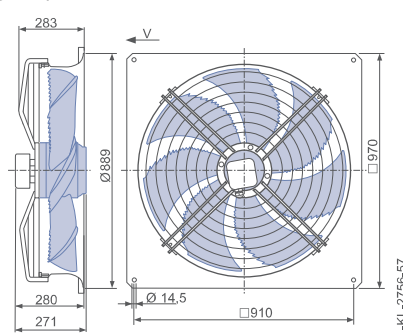

# FE2owlet

for three phase alternating current, 6-6 pole

FN080-SD



## Description

Motor technology: AC  
 Rated voltage  $U_N$ : 3- 400 V ( $\Delta/Y$ )  $\pm 10$  %\*  
 Rated frequency  $f_N$ : 50 Hz\* (60Hz data available)  
 Input power  $P_i$ : 1.65/0.82 kW\*  
 Rated current  $I_N$ : 3.50/1.60 A\*  
 Rated speed  $n_N$ : 790/ 560 min<sup>-1</sup>\*  
 Starting current  $I_s$ : 9.50 / 3.00 A  
 Current increase  $\Delta I$ : 0 %  
 Thermal class: THCL155\*  
 Min. permitted ambient temperature  $t_{R(min)}$ : -40 °C  
 Max. permitted ambient temperature  $t_{R(max)}$ : 70 °C  
 Electrical connection: Terminal box  
 Number of blades: 7  
 Protection class: IP54  
 Motor protection: thermal contact  
 Blades: Aluminium, uncoated  
 Rotor: Aluminium, uncoated  
 Conformity: ErP 2015, CE  
**ErP-data**  
 Efficiency  $\eta_{stat}^A$ : 35.1 %  
 Efficiency:  $N_{actual} = 40.2 / N_{target} = 40$ \*\*  
 \* Rated data  
 \*\*ErP 2015

## Characteristic curve

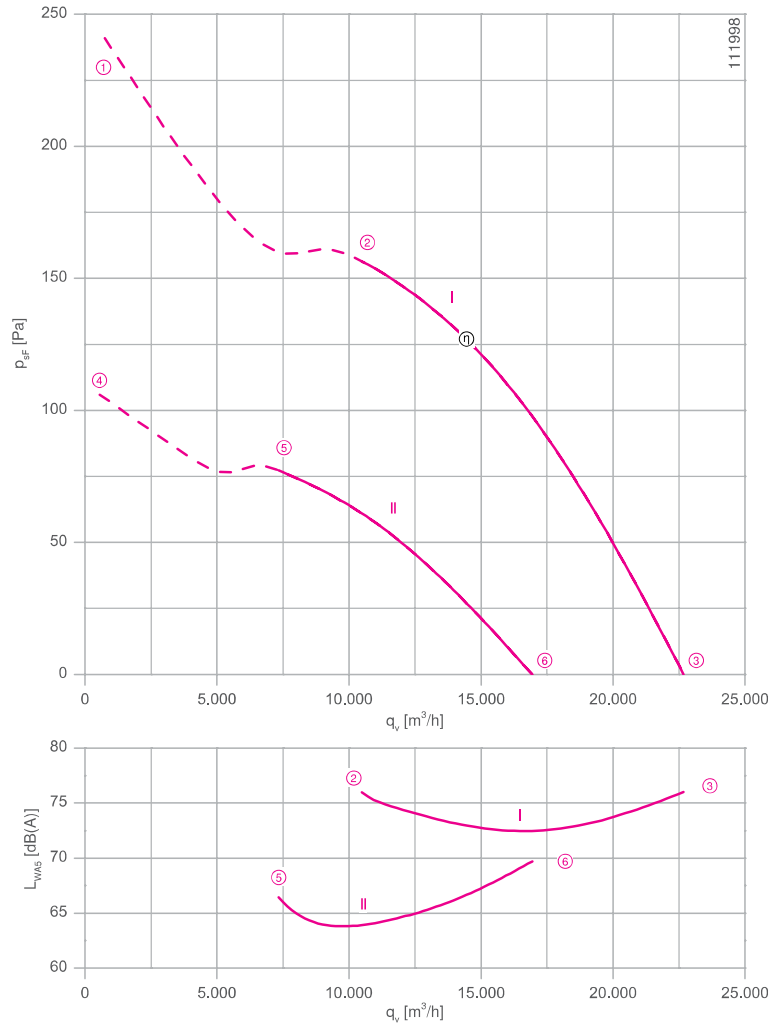

Measured in full bell mouth without guard grille in installation type A according to ISO 5801.

Connection diagram Page 531  
1360-108XA

System components Page 430

## Dimensions mm



Design K - axial bolted, mounted for short bell mouth, guard grille pressure side

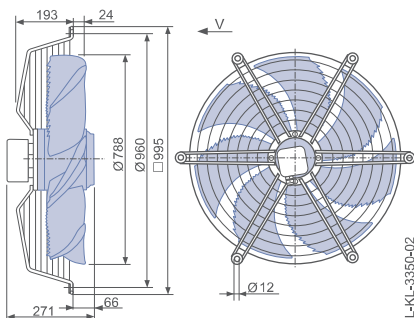

Design S - radially bolted, mounted for short bell mouth, guard grille pressure side

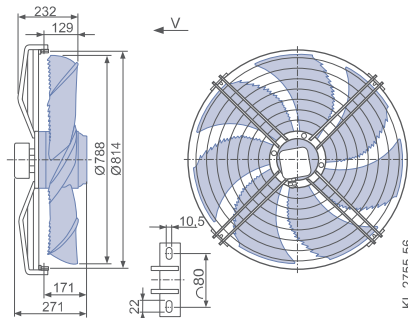

Design I - axial bolted, mounting for bell mouth flange, guard grille pressure side

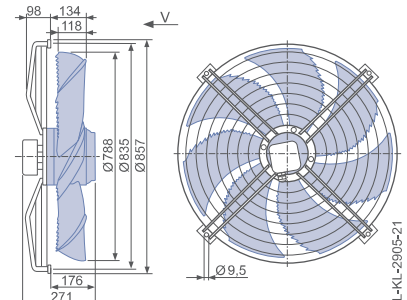





Performance data

Type	Connection	Characteristic curve	Voltage	Operating point	Current	Input power	Speed	Suction side sound power level $L_{WA5}$ dB(A)
			U V					
FN080-SD_.6N.V7P5	Δ	I	400	①	4.00	1950	730	
			400*	②	3.50*	1650*	790*	76
			400	③	3.00	1250	860	76
	Y	II	400	④	1.70	880	490	
			400*	⑤	1.55*	820*	560*	67
			400	⑥	1.40	720	650	70

\*rated data

Fan ordering information

Airflow direction V

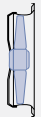
Design	K (guard grille pressure side)	S (guard grille pressure side)	I (guard grille pressure side)	F (without guard grille)	Q (guard grille pressure side)
					
<b>Type</b>	FN080-SDK.6N.V7P5	FN080-SDS.6N.V7P5	FN080-SDI.6N.V7P5	FN080-SDF.6N.V7P5	FN080-SDQ.6N.V7P5
<b>Article no.</b>	168893	168892	168890	168894	168891
<b>Weight kg</b>	37.90	33.00	33.60	45.80	42.60

Control technology

Frequency inverters Fcontrol 3~	Motor protection units 3~	Electronic voltage controllers 3~
		
Page 480	Page 518	Page 506

Design F - flange ring with two flanges, without guard grille

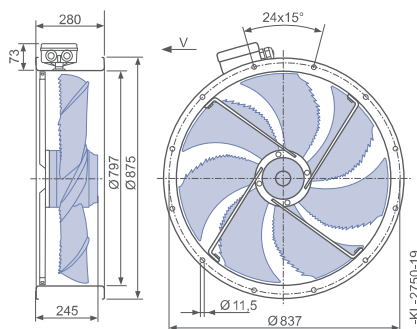

Design Q - square full bell mouth, guard grille pressure side

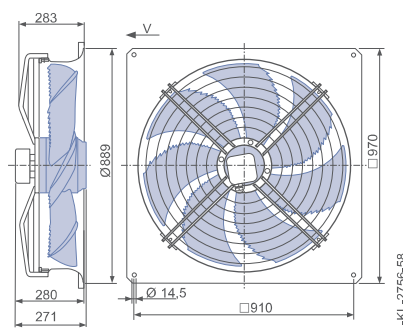



# FE2owlet

for three phase alternating current, 8-8 pole

FN080-AD



## Description

Motor technology: AC  
 Rated voltage  $U_N$ : 3- 400 V ( $\Delta/Y$ )  $\pm 10$  %\*  
 Rated frequency  $f_N$ : 50 Hz\* (60Hz data available)  
 Input power  $P_i$ : 0.82/0.48 kW\*  
 Rated current  $I_N$ : 2.10/1.00 A\*  
 Rated speed  $n_N$ : 670/550 min<sup>-1</sup>\*  
 Starting current  $I_s$ : 5.50 / 1.60 A  
 Current increase  $\Delta I$ : 0 %  
 Thermal class: THCL155\*  
 Min. permitted ambient temperature  $t_{R(min)}$ : -40 °C  
 Max. permitted ambient temperature  $t_{R(max)}$ : 70 °C  
 Electrical connection: Terminal box  
 Number of blades: 7  
 Protection class: IP54  
 Motor protection: thermal contact  
 Blades: Aluminium, uncoated  
 Rotor: Aluminium, uncoated  
 Conformity: ErP 2015, CE  
**ErP-data**  
 Efficiency  $\eta_{statA}$ : 33.4 %  
 Efficiency:  $N_{actual} = 40.3 / N_{target} = 40$ \*\*  
 \* Rated data  
 \*\*ErP 2015

## Characteristic curve

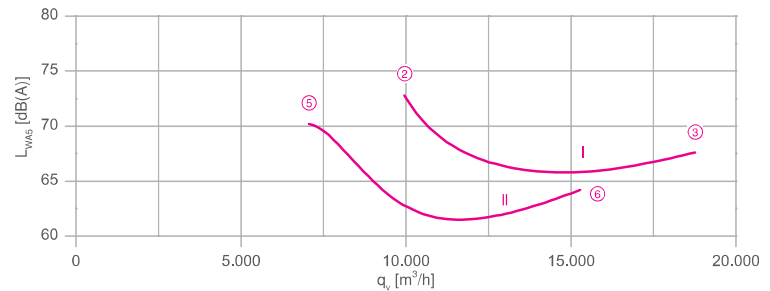
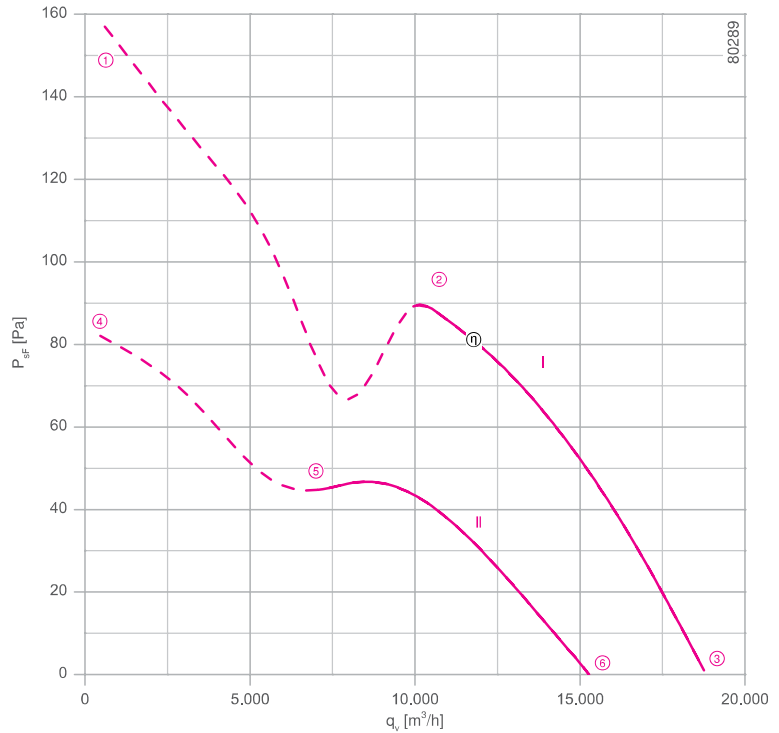

Measured in full bell mouth without guard grille in installation type A according to ISO 5801

Connection diagram Page 531  
1360-108XA

System components Page 430

## Dimensions mm

Airflow direction V

Design S - radially bolted, mounted for short bell mouth, guard grille pressure side

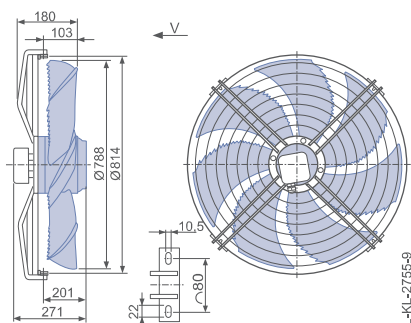

Design I - axial bolted, mounting for bell mouth flange, guard grille pressure side

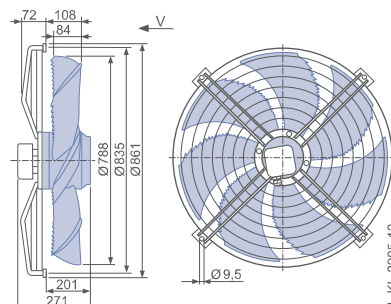

Design Q - square full bell mouth, guard grille pressure side

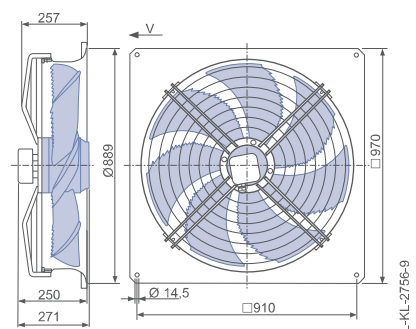

### Performance data

Type	Connection	Characteristic curve	Voltage	Operating point	Current	Input power	Speed	Suction side sound power level $L_{WA5}$ dB(A)
			U V					
FN080-AD_6N_7	Δ	I	400	①	2.40	1050	640	
			400*	②	2.10*	820*	670*	73
			400	③	2.00	700	690	68
	Y	II	400	④	1.20	580	460	
			400*	⑤	1.00*	480*	550*	70
			400	⑥	0.98	460	560	64

\*rated data

### Fan ordering information

Airflow direction V			
Design	S (guard grille pressure side)	I (guard grille pressure side)	Q (guard grille pressure side)
			
<b>Type</b>	<b>FN080-ADS.6N.V7</b>	<b>FN080-ADI.6N.V7</b>	<b>FN080-ADQ.6N.V7</b>
<b>Article no.</b>	<b>138763</b>	<b>153397</b>	<b>138764</b>
<b>Weight kg</b>	36.50	36.10	50.90

### Control technology

Frequency inverters Fcontrol 3~	Motor protection units 3~	Electronic voltage controllers 3~
		
Page 480	Page 518	Page 506

# FE2owlet

for three phase alternating current, 8-8 pole

FNO80-AD



## Description

Motor technology: AC  
 Rated voltage  $U_N$ : 3- 400 V ( $\Delta/Y$ )  $\pm 10$  %\*  
 Rated frequency  $f_N$ : 50 Hz\* (60Hz data available)  
 Input power  $P_i$ : 0.84/0.46 kW\*  
 Rated current  $I_N$ : 2.20/1.00 A\*  
 Rated speed  $n_N$ : 650/ 480  $\text{min}^{-1}$ \*  
 Starting current  $I_s$ : 5.50 / 1.60 A  
 Current increase  $\Delta I$ : 0 %  
 Thermal class: THCL155\*  
 Min. permitted ambient temperature  $t_{R(\text{min})}$ : -40 °C  
 Max. permitted ambient temperature  $t_{R(\text{max})}$ : 70 °C  
 Electrical connection: Terminal box  
 Number of blades: 7  
 Protection class: IP54  
 Motor protection: thermal contact  
 Blades: Aluminium, uncoated  
 Rotor: Aluminium, uncoated  
 Conformity: ErP 2015, CE  
**ErP-data**  
 Efficiency  $\eta_{\text{stat}^A}$ : 33.1 %  
 Efficiency:  $N_{\text{actual}} = 40.1 / N_{\text{target}} = 40$ \*\*  
 \* Rated data  
 \*\*ErP 2015

## Characteristic curve

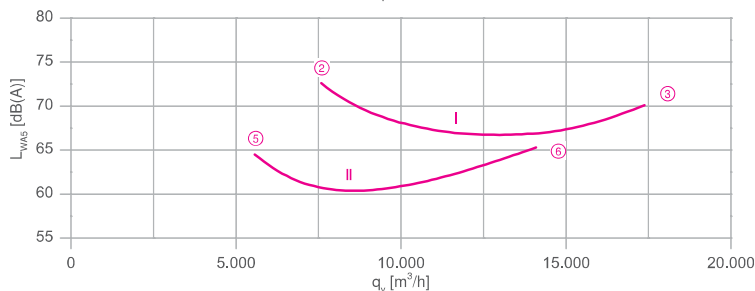
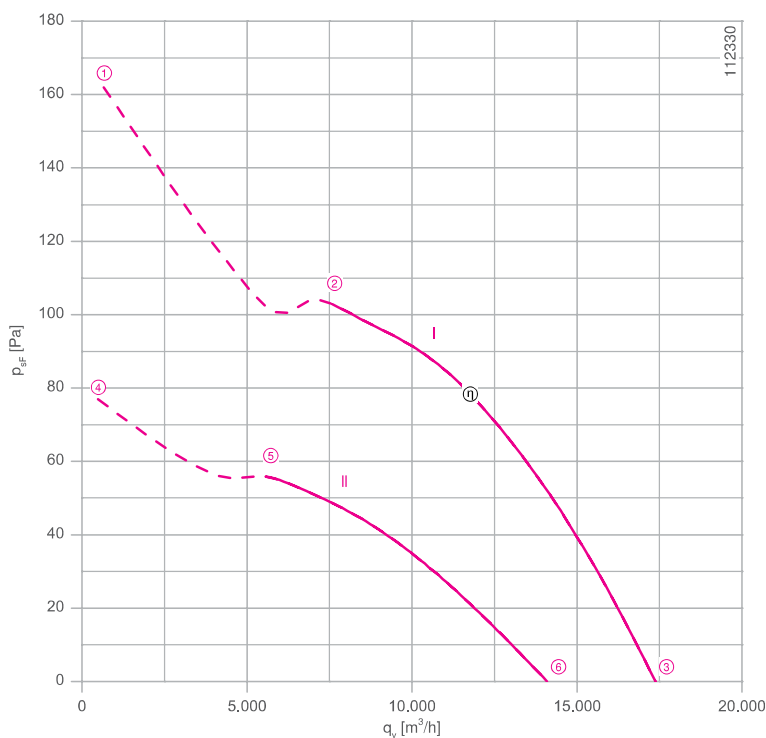

Measured in full bell mouth without guard grille in installation type A according to ISO 5801

Connection diagram Page 531  
1360-108XA

System components Page 430

## Dimensions mm



Design K - axial bolted, mounted for short bell mouth, guard grille pressure side

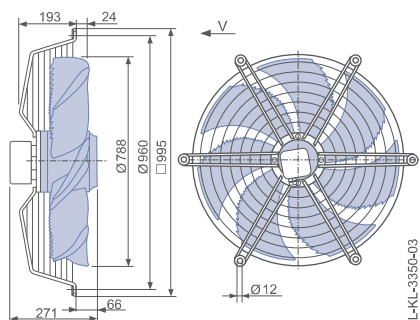

Design S - radially bolted, mounted for short bell mouth, guard grille pressure side

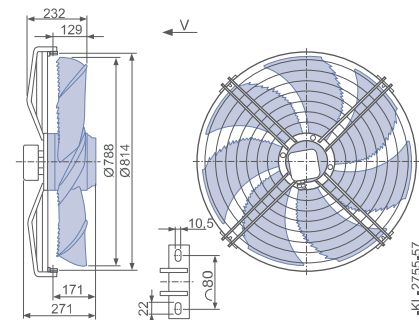

Design I - axial bolted, mounting for bell mouth flange, guard grille pressure side

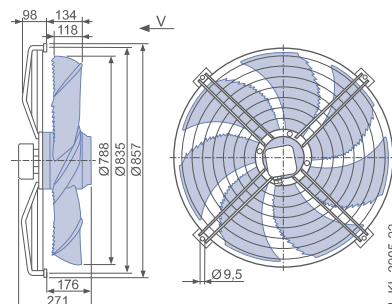



Performance data

Type	Connection	Characteristic curve	Voltage	Operating point	Current	Input power	Speed	Suction side sound power level $L_{WA5}$ dB(A)
			U V					
FN080-AD_6N.V7P5	Δ	I	400	①	2.50	1050	610	
			400*	②	2.20*	840*	650*	73
			400	③	1.90	620	690	70
	Y	II	400	④	1.10	520	420	
			400*	⑤	1.00*	460*	480*	65
			400	⑥	0.88	400	550	65

\*rated data

Fan ordering information

Airflow direction V

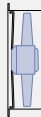
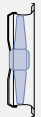
Design	K (guard grille pressure side)	S (guard grille pressure side)	I (guard grille pressure side)	F (without guard grille)	Q (guard grille pressure side)
					
<b>Type</b>	FN080-ADK.6N.V7P5	FN080-ADS.6N.V7P5	FN080-ADI.6N.V7P5	FN080-ADF.6N.V7P5	FN080-ADQ.6N.V7P5
<b>Article no.</b>	168901	168900	168898	168902	168899
<b>Weight kg</b>	37.90	33.00	33.60	45.80	42.60

Control technology

 Frequency inverters Fcontrol 3~ Page 480	 Motor protection units 3~ Page 518	 Electronic voltage controllers 3~ Page 506
--	--	--

Design F - flange ring with two flanges, without guard grille

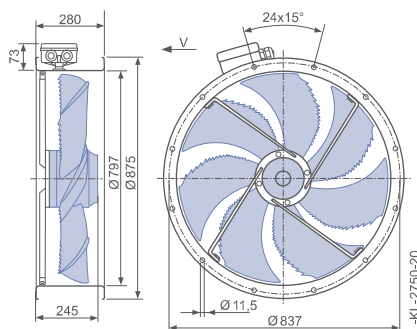

Design Q - square full bell mouth, guard grille pressure side

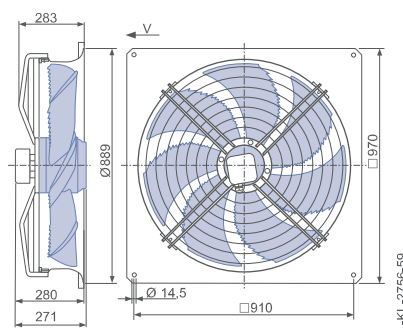

# FE2owlet

for three phase alternating current, 4-4 pole

FN091-VD

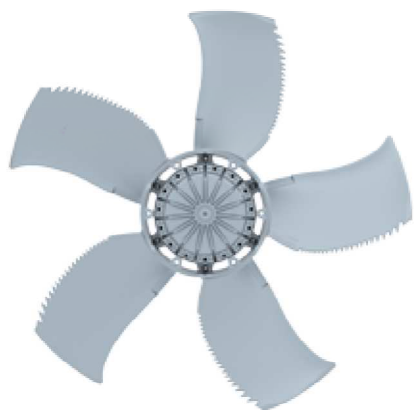

## Description

Motor technology: AC  
 Rated voltage  $U_N$ : 3- 400 V ( $\Delta/Y$ )  $\pm 10\%$ \*  
 Rated frequency  $f_N$ : 5 Hz\*  
 Input power  $P_i$ : 5.20/3.10 kW\*  
 Rated current  $I_N$ : 8.80/5.00 A\*  
 Rated speed  $n_N$ : 1210/900 min<sup>-1</sup>\*  
 Starting current  $I_s$ : 32.00 / 10.00 A  
 Current increase  $\Delta I$ : 0 %  
 Thermal class: **THCL155\***  
 Min. permitted ambient temperature  $t_{R(min)}$ : -40 °C  
 Max. permitted ambient temperature  $t_{R(max)}$ : 40 °C  
 Electrical connection: Terminal box  
 Number of blades: 5  
 Protection class: IP54  
 Motor protection: thermal contact  
 Blades: Aluminium, uncoated  
 Rotor: Aluminium, uncoated  
 Conformity: ErP 2015, CE  
**ErP-data**  
 Efficiency  $\eta_{statA}$ : 38.5 %  
 Efficiency:  $N_{actual} = 40.5 / N_{target} = 40^{**}$   
 \* Rated data  
 \*\*ErP 2015

## Characteristic curve

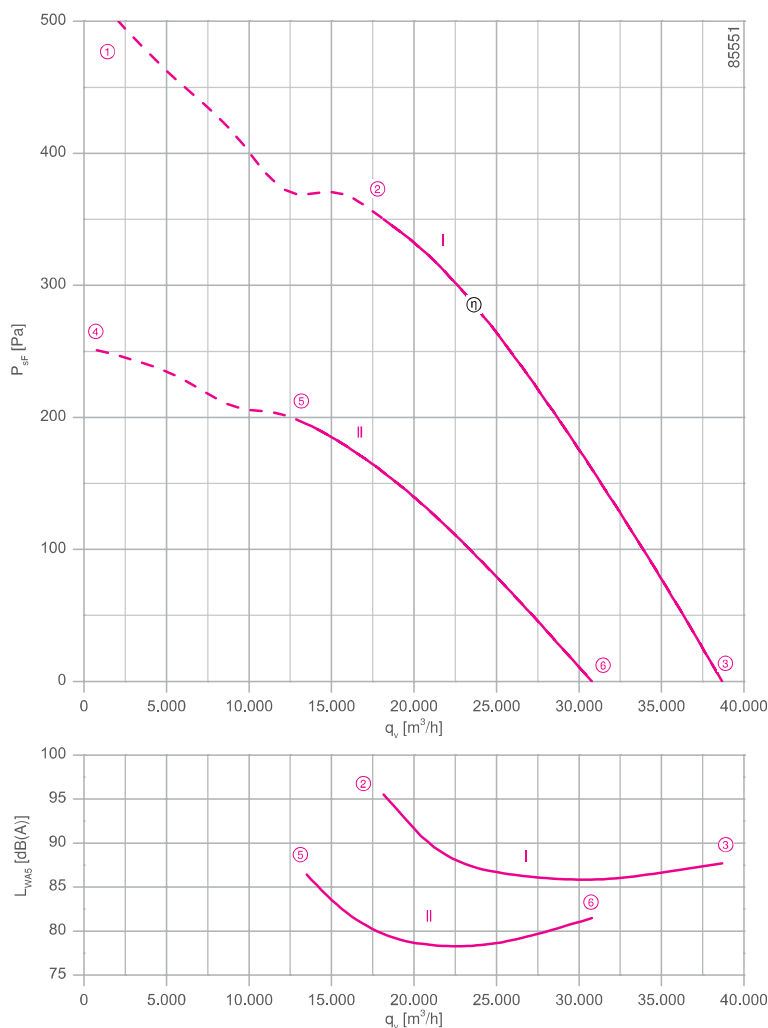

Measured in full bell mouth without guard grille in installation type A according to ISO 5801

Connection diagram Page 531  
 for airflow direction A 1360-108XB  
 for airflow direction V 1360-108XA

System components Page 430

## Dimensions mm

### Airflow direction A

Design Q - square full bell mouth, without guard grille

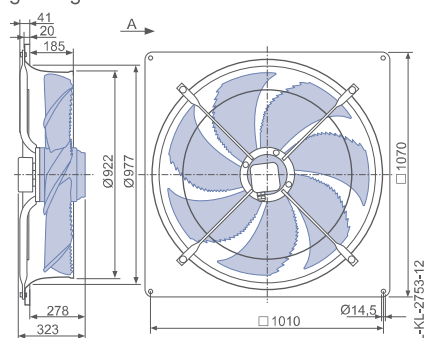

### Airflow direction V

Design S - radially bolted, mounted for short bell mouth, guard grille pressure side

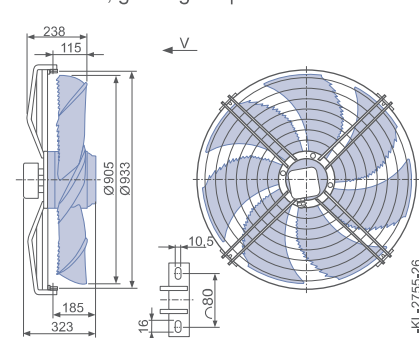

Design I - axial bolted, mounting for bell mouth flange, guard grille pressure side

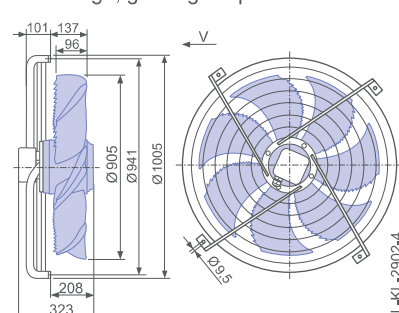

Performance data

Type	Connection	Characteristic curve	Voltage	Operating point	Current	Input power	Speed	Suction side sound power level $L_{WA5}$ dB(A)
			U V					
FN091-VD_7Q_5P1	Δ	I	400	①	11.00	6800	1110	
			400*	②	8.80*	5200*	1210*	96
			400	③	6.80	3800	1300	88
	Y	II	400	④	5.80	3600	750	
			400*	⑤	5.00*	3100*	900*	87
			400	⑥	4.20	2500	1040	82

\*rated data

Fan ordering information

Design	Q (without guard grille)	S (guard grille pressure side)	I (guard grille pressure side)	Q (guard grille pressure side)
<b>Type</b>	<b>FN091-VDQ.7Q.A5P1</b>	<b>FN091-VDS.7Q.V5P1</b>	<b>FN091-VDI.7Q.V5P1</b>	<b>FN091-VDQ.7Q.V5P1</b>
<b>Article no.</b>	<b>155924</b>	<b>155926</b>	<b>155928</b>	<b>155927</b>
<b>Weight kg</b>	64.70	52.70	52.00	69.30

Control technology

Frequency inverters Fcontrol 3~ 	Motor protection units 3~ 	Electronic voltage controllers 3~ 
Page 480	Page 518	Page 506

Design Q - square full bell mouth, guard grille pressure side

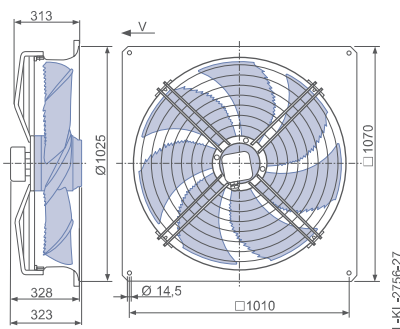

# FE2owlet

for three phase alternating current, 6-6 pole

FNO91-SD

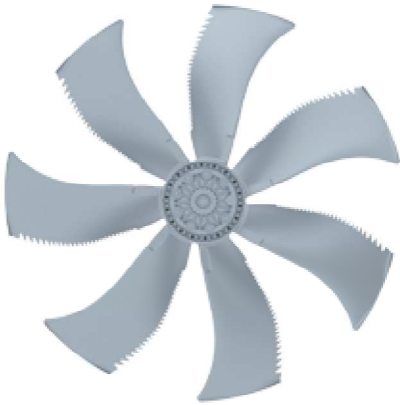

## Description

Motor technology: AC  
 Rated voltage  $U_N$ : 3- 400 V ( $\Delta/Y$ )  $\pm 10$  %\*  
 Rated frequency  $f_N$ : 50 Hz\* (60Hz data available)  
 Input power  $P_i$ : 1.85/1.05 kW\*  
 Rated current  $I_N$ : 3.80/1.90 A\*  
 Rated speed  $n_N$ : 840/ 630  $\text{min}^{-1}$ \*  
 Starting current  $I_s$ : 11.00 / 3.40 A  
 Current increase  $\Delta I$ : 0 %  
 Thermal class: THCL155\*  
 Min. permitted ambient temperature  $t_{R(\text{min})}$ : -40 °C  
 Max. permitted ambient temperature  $t_{R(\text{max})}$ : 70 °C  
 Electrical connection: Terminal box  
 Number of blades: 7  
 Protection class: IP54  
 Motor protection: thermal contact  
 Blades: Aluminium, uncoated  
 Rotor: Aluminium, uncoated  
 Conformity: ErP 2015, CE  
**ErP-data**  
 Efficiency  $\eta_{\text{statA}}$ : 39.2 %  
 Efficiency:  $N_{\text{actual}} = 44.0 / N_{\text{target}} = 40$ \*\*  
 \* Rated data  
 \*\*ErP 2015

## Characteristic curve

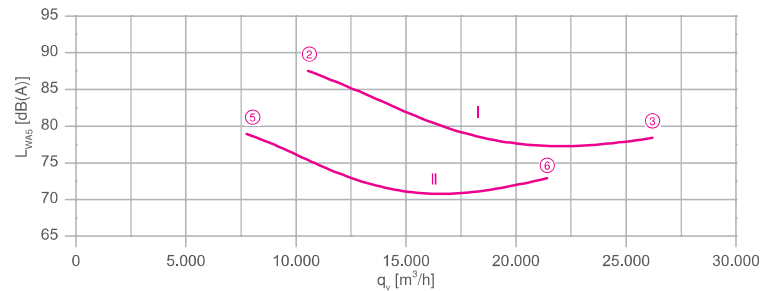
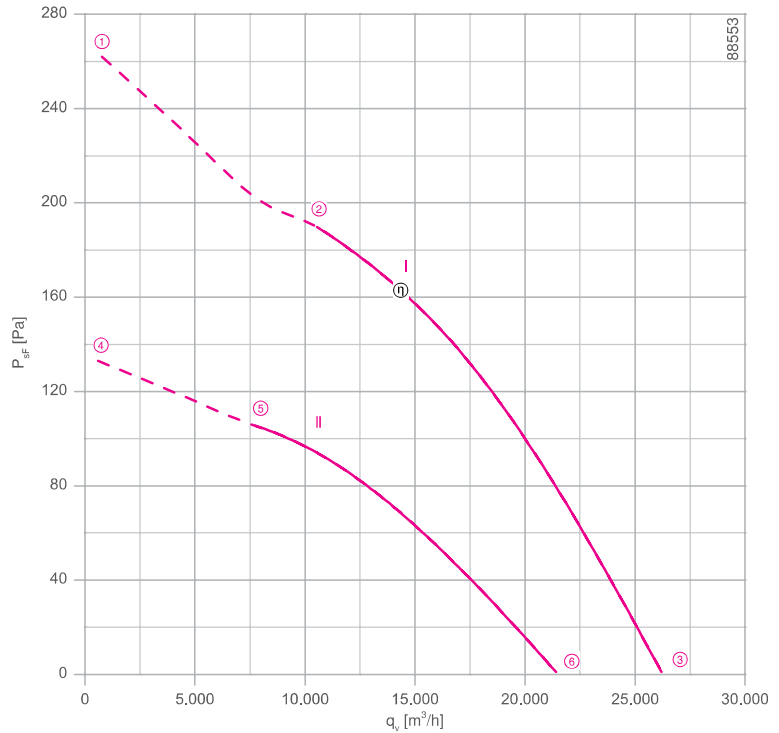

Measured in full bell mouth without guard grille in installation type A according to ISO 5801

Connection diagram Page 531  
1360-108XA

System components Page 430

## Dimensions mm



Design S - radially bolted, mounted for short bell mouth, guard grille pressure side

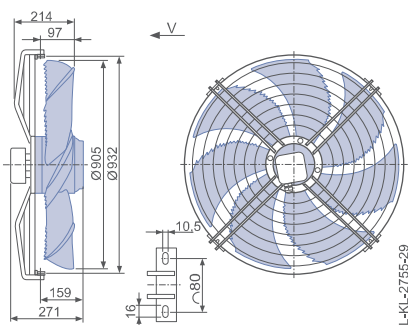

Design I - axial bolted, mounting for bell mouth flange, guard grille pressure side

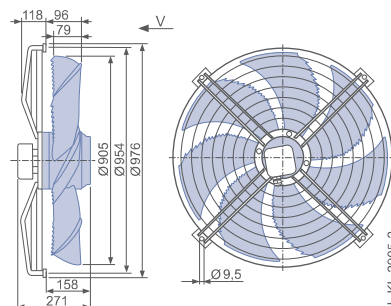

Design Q - square full bell mouth, guard grille pressure side

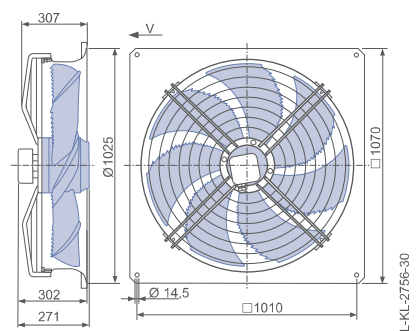

### Performance data

Type	Connection	Characteristic curve	Voltage	Operating point	Current	Input power	Speed	Suction side sound power level $L_{WA5}$ dB(A)
			U V					
FN091-SD_6N_7P2	Δ	I	400	①	4.40	2200	790	
			400*	②	3.80*	1850*	840*	88
			400	③	3.10	1250	900	78
	Y	II	400	④	2.10	1200	560	
			400*	⑤	1.90*	1050*	630*	79
			400	⑥	1.55	840	730	73

\*rated data

### Fan ordering information

Airflow direction V			
Design	S (guard grille pressure side)	I (guard grille pressure side)	Q (guard grille pressure side)
			
<b>Type</b>	<b>FN091-SDS.6N.V7P2</b>	<b>FN091-SDI.6N.V7P2</b>	<b>FN091-SDQ.6N.V7P2</b>
<b>Article no.</b>	<b>156205</b>	<b>156203</b>	<b>156204</b>
<b>Weight kg</b>	34.10	34.20	50.70

### Control technology

Frequency inverters Fcontrol 3~	Motor protection units 3~	Electronic voltage controllers 3~
		
Page 480	Page 518	Page 506



# FE2owlet

for three phase alternating current, 6-6 pole

FN091-SD

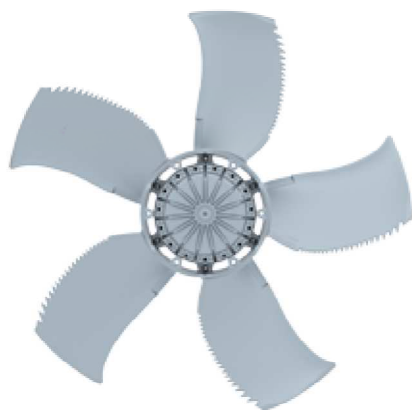

## Description

Motor technology: AC  
 Rated voltage  $U_N$ : 3- 400 V ( $\Delta/Y$ )  $\pm 10$  %\*  
 Rated frequency  $f_N$ : 50 Hz\* (60Hz data available)  
 Input power  $P_i$ : 1.95/1.30 kW\*  
 Rated current  $I_N$ : 4.40/2.30 A\*  
 Rated speed  $n_N$ : 880/ 720  $\text{min}^{-1}$ \*  
 Starting current  $I_s$ : 17.00 / 5.50 A  
 Current increase  $\Delta I$ : 0 %  
 Thermal class: THCL155\*  
 Min. permitted ambient temperature  $t_{R(\text{min})}$ : -40 °C  
 Max. permitted ambient temperature  $t_{R(\text{max})}$ : 70 °C  
 Electrical connection: Terminal box  
 Number of blades: 5  
 Protection class: IP54  
 Motor protection: thermal contact  
 Blades: Aluminium, uncoated  
 Rotor: Aluminium, uncoated  
 Conformity: ErP 2015, CE  
**ErP-data**  
 Efficiency  $\eta_{\text{statA}}$ : 40.8 %  
 Efficiency:  $N_{\text{actual}} = 45.4 / N_{\text{target}} = 40$ \*\*  
 \* Rated data  
 \*\*ErP 2015

## Characteristic curve

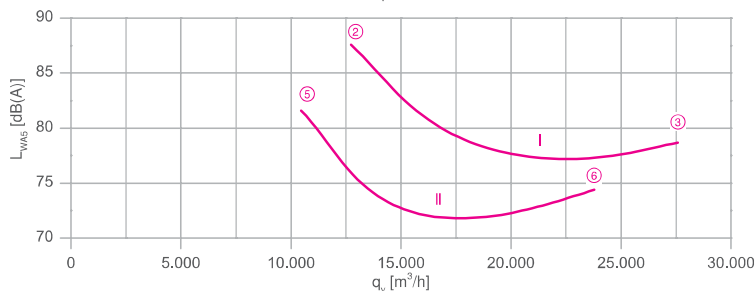
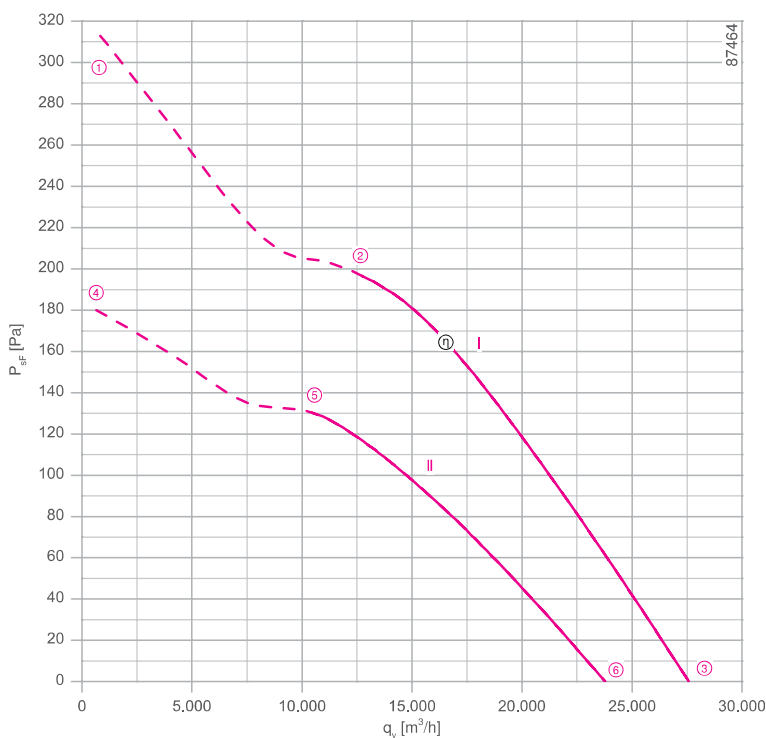

Measured in full bell mouth without guard grille in installation type A according to ISO 5801

Connection diagram Page 531  
 for airflow direction A 1360-108XB  
 for airflow direction V 1360-108XA

System components Page 430

## Dimensions mm

### Airflow direction A

Design Q - square full bell mouth, without guard grille

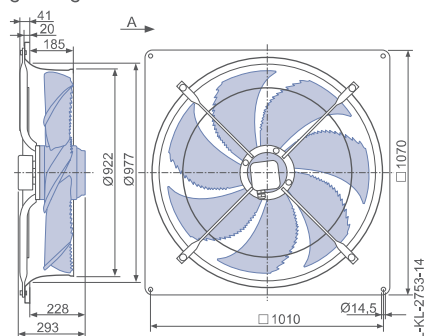

### Airflow direction V

Design S - radially bolted, mounted for short bell mouth, guard grille pressure side

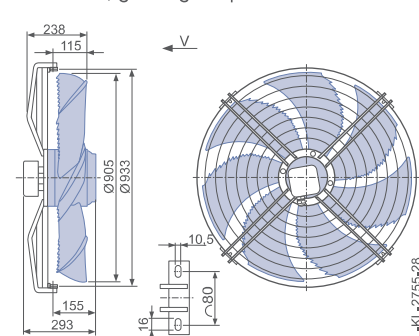

Design I - axial bolted, mounting for bell mouth flange, guard grille pressure side

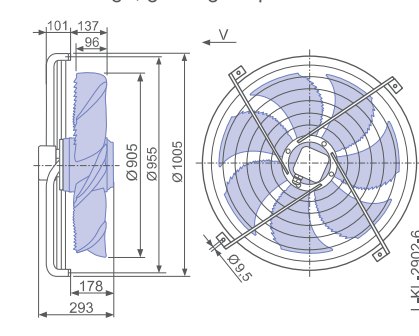

Performance data

Type	Connection	Characteristic curve	Voltage	Operating point	Current	Input power	Speed	Suction side sound power level $L_{WA5}$ dB(A)
			U V					
FN091-SD_7M_5P1	Δ	I	400	①	5.40	2700	830	
			400*	②	4.40*	1950*	880*	88
			400	③	3.90	1400	920	79
	Y	II	400	④	2.80	1600	620	
			400*	⑤	2.30*	1300*	720*	82
			400	⑥	1.80	1000	800	74

\*rated data

Fan ordering information

	Airflow direction A	Airflow direction V		
Design	Q (without guard grille)	S (guard grille pressure side)	I (guard grille pressure side)	Q (guard grille pressure side)
Type	FN091-SDQ.7M.A5P1	FN091-SDS.7M.V5P1	FN091-SDI.7M.V5P1	FN091-SDQ.7M.V5P1
Article no.	156181	156183	156185	156184
Weight kg	58.20	46.40	45.90	63.00

Control technology

Frequency inverters Fcontrol 3~	Motor protection units 3~	Electronic voltage controllers 3~
Page 480	Page 518	Page 506

Design Q - square full bell mouth, guard grille pressure side

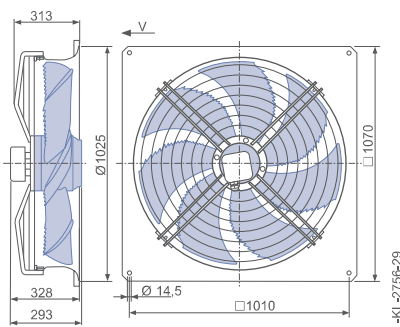

# FE2owlet

for three phase alternating current, 8-8 pole

FNO91-AD

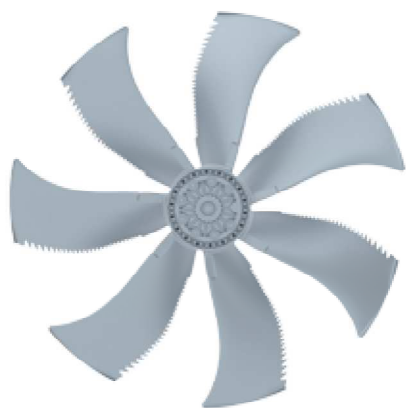

## Description

Motor technology: AC  
 Rated voltage  $U_N$ : 3- 400 V ( $\Delta/Y$ )  $\pm 10$  %\*  
 Rated frequency  $f_N$ : 50 Hz\* (60Hz data available)  
 Input power  $P_i$ : 0.90/0.54 kW\*  
 Rated current  $I_N$ : 2.20/1.10 A\*  
 Rated speed  $n_N$ : 660/ 500  $\text{min}^{-1}$ \*  
 Starting current  $I_s$ : 5.50 / 1.60 A  
 Current increase  $\Delta I$ : 0 %  
 Thermal class: **THCL155\***  
 Min. permitted ambient temperature  $t_{R(\text{min})}$ : -40 °C  
 Max. permitted ambient temperature  $t_{R(\text{max})}$ : 70 °C  
 Electrical connection: Terminal box  
 Number of blades: 7  
 Protection class: IP54  
 Motor protection: thermal contact  
 Blades: Aluminium, uncoated  
 Rotor: Aluminium, uncoated  
 Conformity: ErP 2015, CE  
**ErP-data**  
 Efficiency  $\eta_{\text{statA}}$ : 36.5 %  
 Efficiency:  $N_{\text{actual}} = 43.2 / N_{\text{target}} = 40$ \*\*  
 \* Rated data  
 \*\*ErP 2015

## Characteristic curve

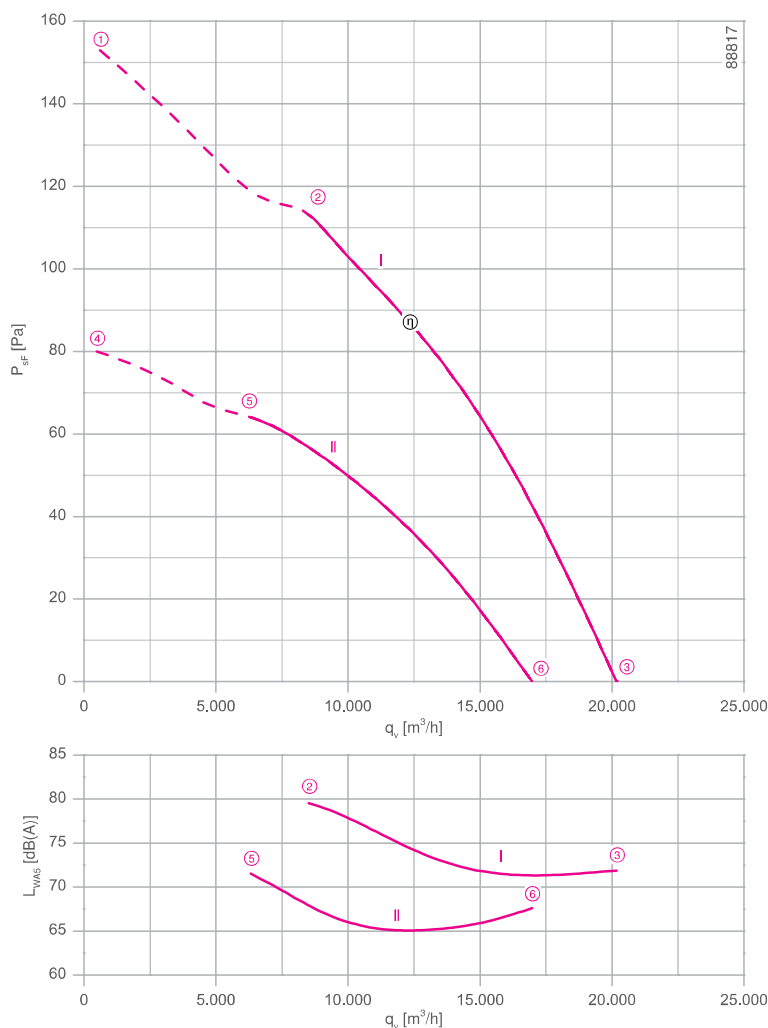

Measured in full bell mouth without guard grille in installation type A according to ISO 5801

Connection diagram Page 531  
1360-108XA

System components Page 430

## Dimensions mm



Design S - radially bolted, mounted for short bell mouth, guard grille pressure side

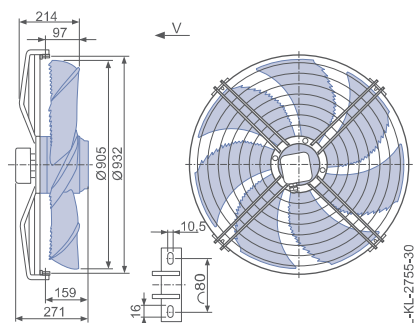

Design I - axial bolted, mounting for bell mouth flange, guard grille pressure side

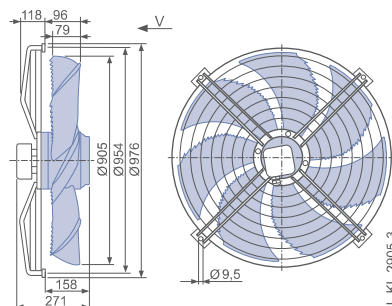

Design Q - square full bell mouth, guard grille pressure side

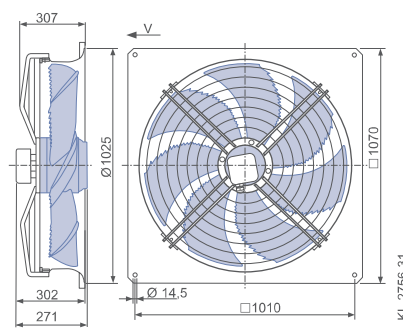

### Performance data

Type	Connection	Characteristic curve	Voltage	Operating point	Current	Input power	Speed	Suction side sound power level $L_{WA5}$ dB(A)
			U V					
FN091-AD_6N_7P2	Δ	I	400	①	2.40	1100	620	
			400*	②	2.20*	900*	660*	80
			400	③	1.85	620	690	72
	Y	II	400	④	1.20	600	440	
			400*	⑤	1.10*	540*	500*	72
			400	⑥	0.90	440	590	68

\*rated data

### Fan ordering information

Airflow direction V			
Design	S (guard grille pressure side)	I (guard grille pressure side)	Q (guard grille pressure side)
			
<b>Type</b>	<b>FN091-ADS.6N.V7P2</b>	<b>FN091-ADI.6N.V7P2</b>	<b>FN091-ADQ.6N.V7P2</b>
<b>Article no.</b>	<b>156215</b>	<b>156213</b>	<b>156214</b>
<b>Weight kg</b>	34.10	34.20	50.70

### Control technology

Frequency inverters Fcontrol 3~	Motor protection units 3~	Electronic voltage controllers 3~
		
Page 480	Page 518	Page 506

# FE2owlet

for three phase alternating current, 12-12 pole

FN091-ND

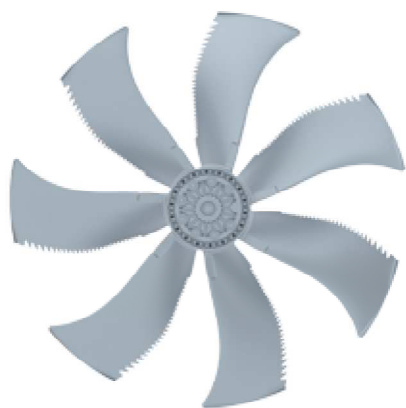

## Description

Motor technology: AC  
 Rated voltage  $U_N$ : 3- 400 V ( $\Delta/Y$ )  $\pm 10$  %\*  
 Rated frequency  $f_N$ : 50 Hz\* (60Hz data available)  
 Input power  $P_i$ : 310/190 W\*  
 Rated current  $I_N$ : 0.83/0.39 A\*  
 Rated speed  $n_N$ : 440/ 340 min<sup>-1</sup>\*  
 Current increase  $\Delta I$ : 0 %  
 Thermal class: THCL155\*  
 Min. permitted ambient temperature  $t_{R(min)}$ : -40 °C  
 Max. permitted ambient temperature  $t_{R(max)}$ : 70 °C  
 Electrical connection: Terminal box  
 Number of blades: 7  
 Protection class: IP54  
 Motor protection: thermal contact  
 Blades: Aluminium, uncoated  
 Rotor: Aluminium, uncoated  
 Conformity: ErP 2015, CE  
**ErP-data**  
 Efficiency  $\eta_{statA}$ : 30.4 %  
 Efficiency:  $N_{actual} = 40.0 / N_{target} = 40$ \*\*  
 \* Rated data  
 \*\*ErP 2015

## Characteristic curve

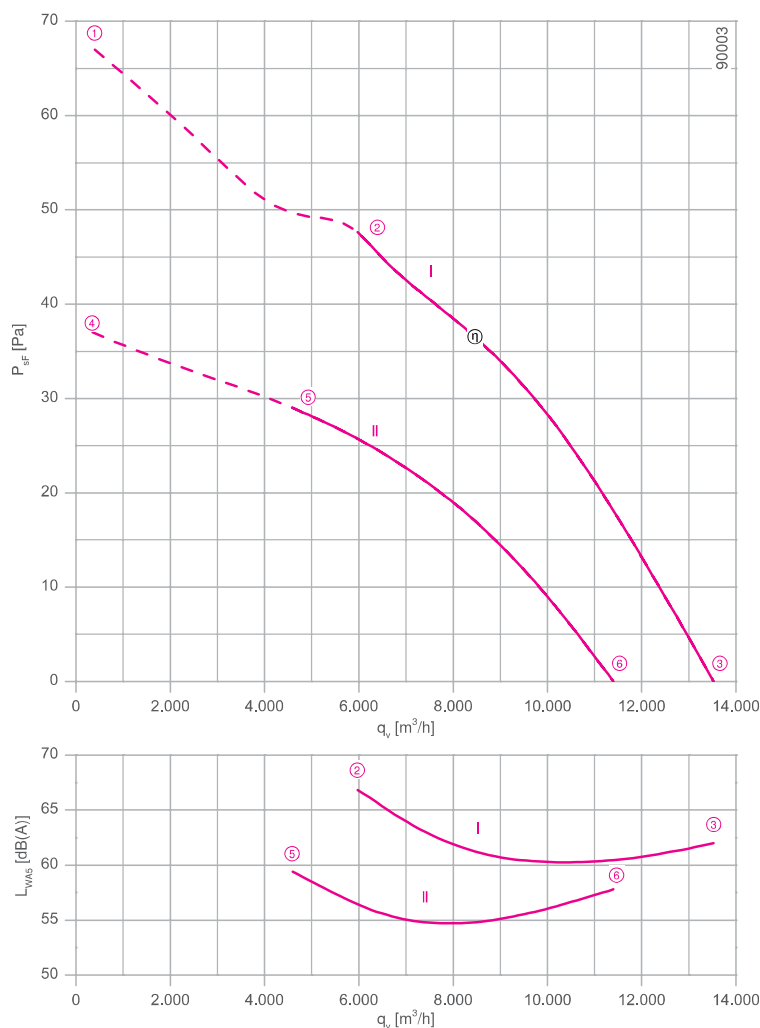

Measured in full bell mouth without guard grille in installation type A according to ISO 5801

Connection diagram Page 531  
1360-108XA

System components Page 430

## Dimensions mm



Design S - radially bolted, mounted for short bell mouth, guard grille pressure side

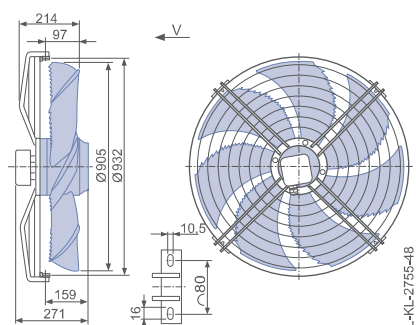

Design I - axial bolted, mounting for bell mouth flange, guard grille pressure side

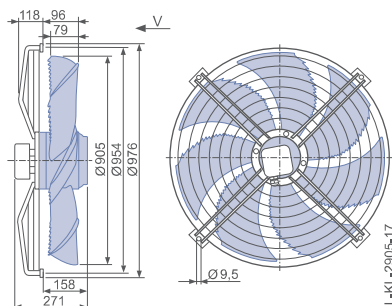

Design Q - square full bell mouth, guard grille pressure side

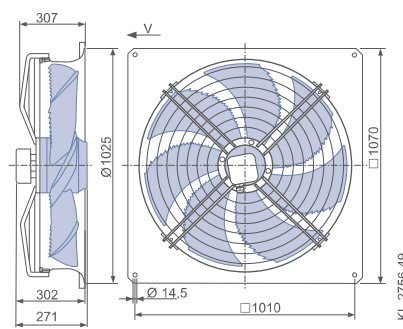

### Performance data

Type	Connection	Characteristic curve	Voltage	Operating point	Current	Input power	Speed	Suction side sound power level $L_{WA5}$ dB(A)
			U V					
FN091-ND_6N_7P2	Δ	I	400	①	0.90	380	420	
			400*	②	0.83*	310*	440*	67
			400	③	0.76	240	460	62
	Y	II	400	④	0.42	210	310	
			400*	⑤	0.39*	190*	340*	59
			400	⑥	0.33	150	390	58

\*rated data

### Fan ordering information

**Airflow direction V**

Design	S (guard grille pressure side)	I (guard grille pressure side)	Q (guard grille pressure side)
			
<b>Type</b>	<b>FN091-NDS.6N.V7P2</b>	<b>FN091-NDI.6N.V7P2</b>	<b>FN091-NDQ.6N.V7P2</b>
<b>Article no.</b>	<b>156219</b>	<b>156217</b>	<b>156218</b>
<b>Weight kg</b>	34.10	34.20	50.70

### Control technology

Frequency inverters Fcontrol 3~	Motor protection units 3~	Electronic voltage controllers 3~
		
Page 480	Page 518	Page 506

# FE2owlet

for three phase alternating current, 6-6 pole

FN100-SD

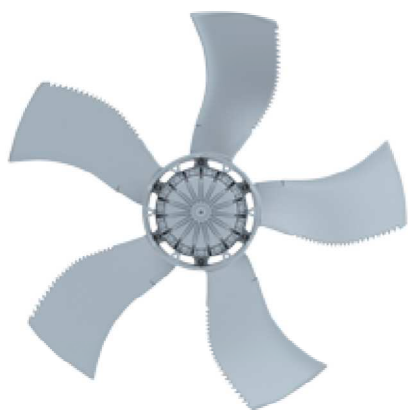

## Description

Motor technology: AC  
 Rated voltage  $U_N$ : 3- 400 V ( $\Delta/Y$ )  $\pm 10$  %\*  
 Rated frequency  $f_N$ : 50 Hz\*  
 Input power  $P_i$ : 3.10/1.95 kW\*  
 Rated current  $I_N$ : 5.60/3.40 A\*  
 Rated speed  $n_N$ : 870/ 660  $\text{min}^{-1}$ \*  
 Starting current  $I_s$ : 22.00 / 6.50 A  
 Current increase  $\Delta I$ : 5 %  
 Thermal class: **THCL155\***  
 Min. permitted ambient temperature  $t_{R(\text{min})}$ : -40 °C  
 Max. permitted ambient temperature  $t_{R(\text{max})}$ : 65 °C  
 Electrical connection: Terminal box  
 Number of blades: 5  
 Protection class: IP54  
 Motor protection: thermal contact  
 Blades: Aluminium, uncoated  
 Rotor: Aluminium, uncoated  
 Conformity: ErP 2015, CE  
**ErP-data**  
 Efficiency  $\eta_{\text{statA}}$ : 38.7 %  
 Efficiency:  $N_{\text{actual}} = 42.1 / N_{\text{target}} = 40$ \*\*  
 \* Rated data  
 \*\*ErP 2015

## Characteristic curve

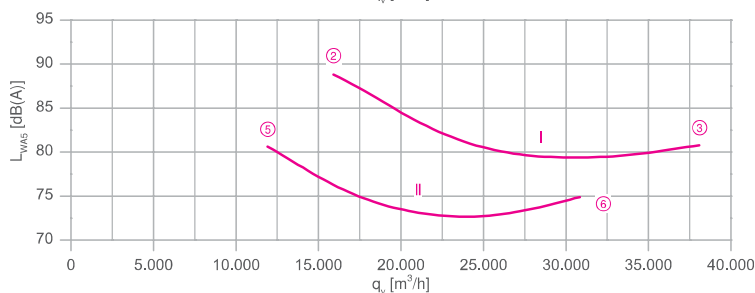
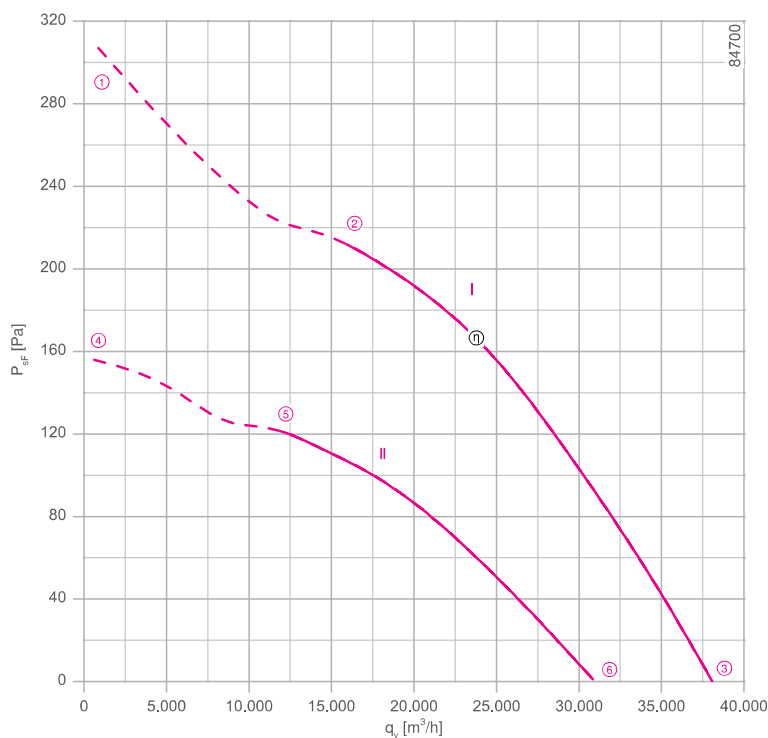

Measured in full bell mouth without guard grille in installation type A according to ISO 5801

Connection diagram Page 531  
 for airflow direction A 1360-108XB  
 for airflow direction V 1360-108XA

System components Page 430

## Dimensions mm

### Airflow direction A

Design Q - square full bell mouth, without guard grille

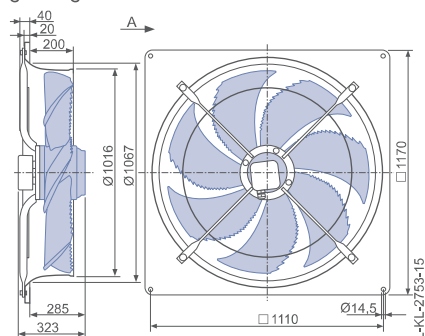

### Airflow direction V

Design S - radially bolted, mounted for short bell mouth, guard grille pressure side

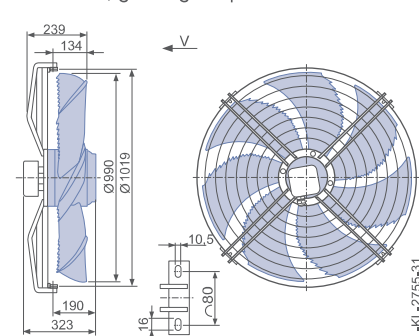

Design I - axial bolted, mounting for bell mouth flange, guard grille pressure side

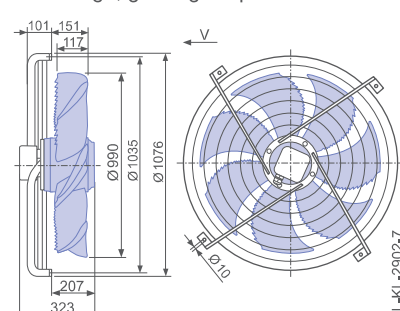

Performance data

Type	Connection	Characteristic curve	Voltage	Operating point	Current	Input power	Speed	Suction side sound power level $L_{WA5}$ dB(A)
			U V					
FN100-SD_7Q_5P1	Δ	I	400	①	6.60	3800	830	
			400*	②	5.60*	3100*	870*	89
			400	③	4.40	2300	910	81
	Y	II	400	④	3.80	2100	590	
			400*	⑤	3.40*	1950*	660*	81
			400	⑥	2.80	1650	740	75

\*rated data

Fan ordering information

Design	Q (without guard grille)	S (guard grille pressure side)	I (guard grille pressure side)	Q (guard grille pressure side)
<b>Type</b>	<b>FN100-SDQ.7Q.A5P1</b>	<b>FN100-SDS.7Q.V5P1</b>	<b>FN100-SDI.7Q.V5P1</b>	<b>FN100-SDQ.7Q.V5P1</b>
<b>Article no.</b>	<b>155854</b>	<b>155858</b>	<b>155856</b>	<b>155857</b>
<b>Weight kg</b>	69.50	55.10	54.30	73.80

Control technology

Frequency inverters Fcontrol 3~  Page 480	Motor protection units 3~  Page 518	Electronic voltage controllers 3~  Page 506
--	--	--

Design Q - square full bell mouth, guard grille pressure side

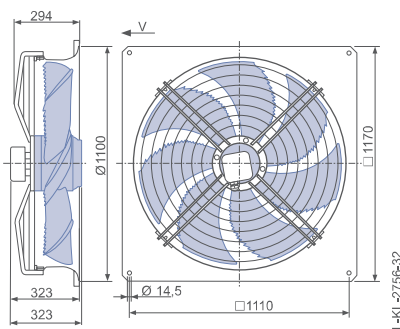



# FE2owlet

for three phase alternating current, 6-6 pole

FN100-SD

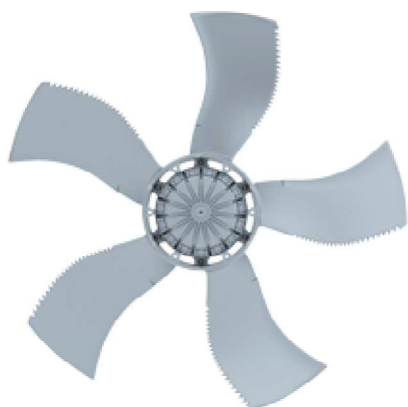

## Description

Motor technology: AC  
 Rated voltage  $U_N$ : 3- 400 V ( $\Delta/Y$ )  $\pm 10$  %  
 Rated frequency  $f_N$ : 50 Hz\* (60Hz data available)  
 Input power  $P_i$ : 2.70/1.60 kW\*  
 Rated current  $I_N$ : 5.40/2.80 A\*  
 Rated speed  $n_N$ : 820/ 620  $\text{min}^{-1}$ \*  
 Starting current  $I_s$ : 18.00 / 6.00 A  
 Current increase  $\Delta I$ : 0 %  
 Thermal class: THCL155\*  
 Min. permitted ambient temperature  $t_{R(\text{min})}$ : -40 °C  
 Max. permitted ambient temperature  $t_{R(\text{max})}$ : 70 °C  
 Electrical connection: Terminal box  
 Number of blades: 5  
 Protection class: IP54  
 Motor protection: thermal contact  
 Blades: Aluminium, uncoated  
 Rotor: Aluminium, uncoated  
 Conformity: ErP 2015, CE  
**ErP-data**  
 Efficiency  $\eta_{\text{statA}}$ : 36.8 %  
 Efficiency:  $N_{\text{actual}} = 40.5 / N_{\text{target}} = 40$ \*\*  
 \* Rated data  
 \*\*ErP 2015

## Characteristic curve

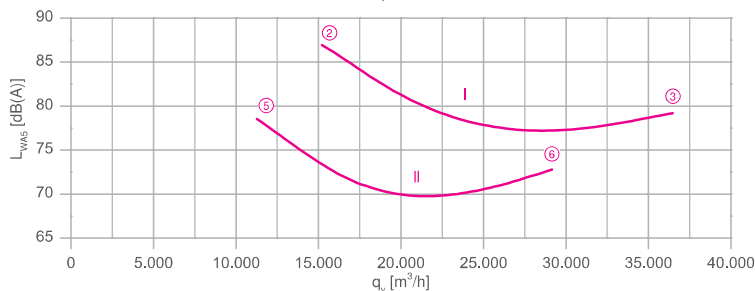
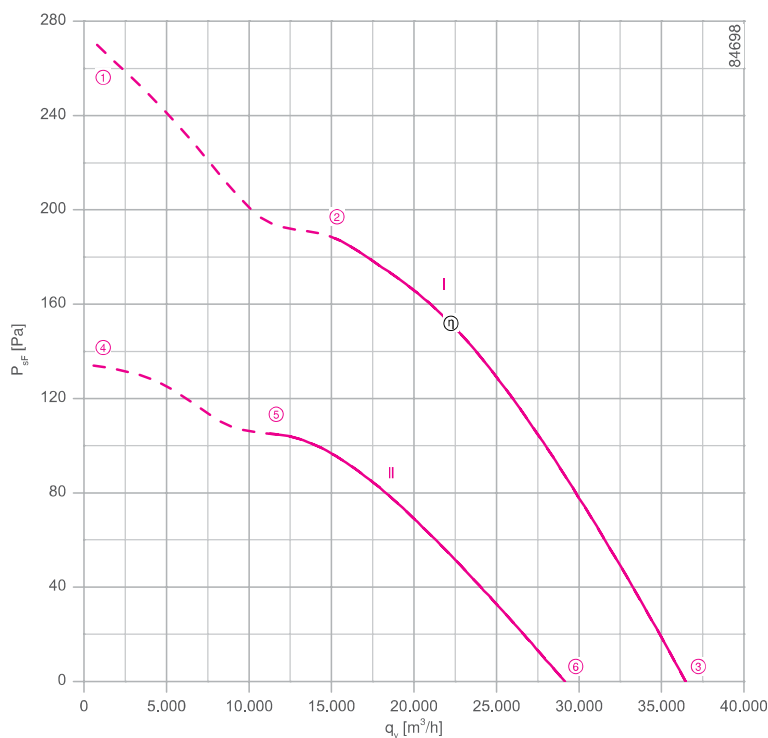

Measured in full bell mouth without guard grille in installation type A according to ISO 5801

Connection diagram Page 531  
 for airflow direction A 1360-108XB  
 for airflow direction V 1360-108XA

System components Page 430

## Dimensions mm

### Airflow direction A

Design Q - square full bell mouth, without guard grille

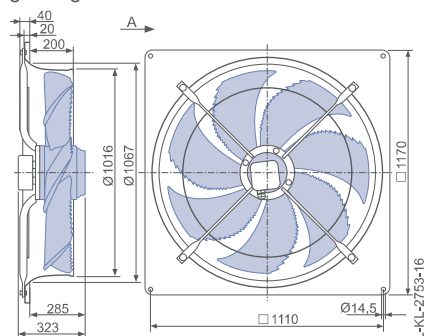

### Airflow direction V

Design S - radially bolted, mounted for short bell mouth, guard grille pressure side

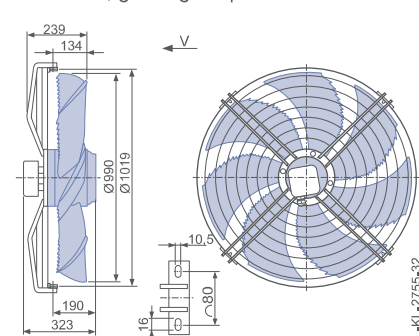

Design I - axial bolted, mounting for bell mouth flange, guard grille pressure side

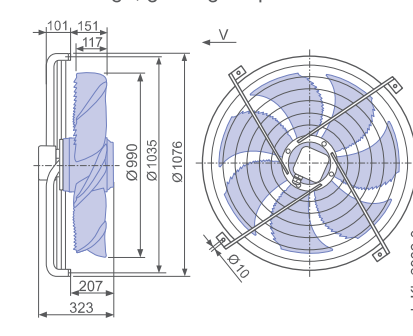

Performance data

Type	Connection	Characteristic curve	Voltage	Operating point	Current	Input power	Speed	Suction side sound power level $L_{WA5}$ dB(A)
			U V					
FN100-SD_7Q_5P1	Δ	I	400	①	6.00	3200	780	
			400*	②	5.40*	2700*	820*	87
			400	③	4.60	2100	870	79
	Y	II	400	④	3.10	1800	560	
			400*	⑤	2.80*	1600*	620*	79
			400	⑥	2.40	1350	700	73

\*rated data

Fan ordering information

Design	Q (without guard grille)	S (guard grille pressure side)	I (guard grille pressure side)	Q (guard grille pressure side)
<b>Type</b>	<b>FN100-SDQ.7Q.A5P1</b>	<b>FN100-SDS.7Q.V5P1</b>	<b>FN100-SDI.7Q.V5P1</b>	<b>FN100-SDQ.7Q.V5P1</b>
<b>Article no.</b>	<b>155860</b>	<b>155864</b>	<b>155862</b>	<b>155863</b>
<b>Weight kg</b>	69.50	55.10	54.30	73.80

Control technology

Frequency inverters Fcontrol 3~ 	Motor protection units 3~ 	Electronic voltage controllers 3~ 
Page 480	Page 518	Page 506

Design Q - square full bell mouth, guard grille pressure side

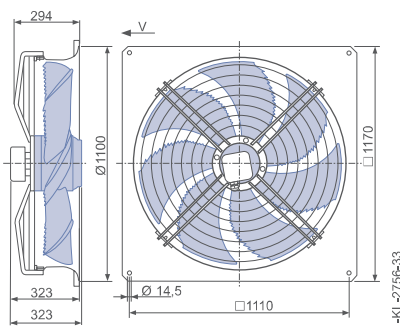

# FE2owlet

for three phase alternating current, 8-8 pole

FN100-AD

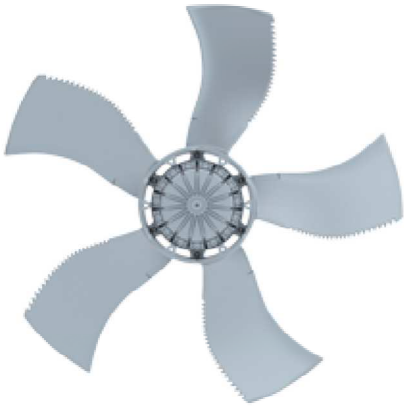

## Description

Motor technology: AC  
 Rated voltage  $U_N$ : 3- 400 V ( $\Delta/Y$ )  $\pm 10\%$ \*  
 Rated frequency  $f_N$ : 50 Hz\*  
 Input power  $P_i$ : 1.55/1.15 kW\*  
 Rated current  $I_N$ : 3.40/2.00 A\*  
 Rated speed  $n_N$ : 690/ 570  $\text{min}^{-1}$ \*  
 Starting current  $I_s$ : 14.00 / 4.40 A  
 Current increase  $\Delta I$ : 5 %  
 Thermal class: THCL155\*  
 Min. permitted ambient temperature  $t_{R(\text{min})}$ : -40 °C  
 Max. permitted ambient temperature  $t_{R(\text{max})}$ : 70 °C  
 Electrical connection: Terminal box  
 Number of blades: 5  
 Protection class: IP54  
 Motor protection: thermal contact  
 Blades: Aluminium, uncoated  
 Rotor: Aluminium, uncoated  
 Conformity: ErP 2015, CE  
**ErP-data**  
 Efficiency  $\eta_{\text{statA}}$ : 38.0 %  
 Efficiency:  $N_{\text{actual}} = 43.2 / N_{\text{target}} = 40^{**}$   
 \* Rated data  
 \*\*ErP 2015

## Characteristic curve

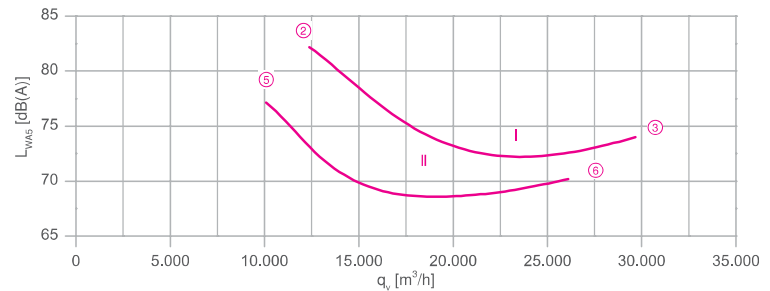
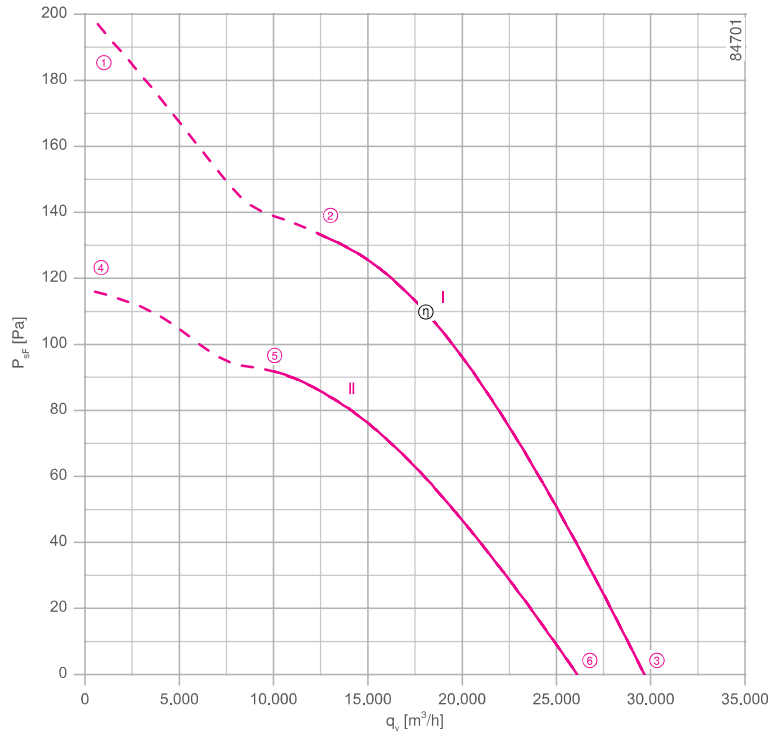

Measured in full bell mouth without guard grille in installation type A according to ISO 5801

Connection diagram Page 531  
 for airflow direction A 1360-108XB  
 for airflow direction V 1360-108XA

System components Page 430

## Dimensions mm

### Airflow direction A

Design Q - square full bell mouth, without guard grille

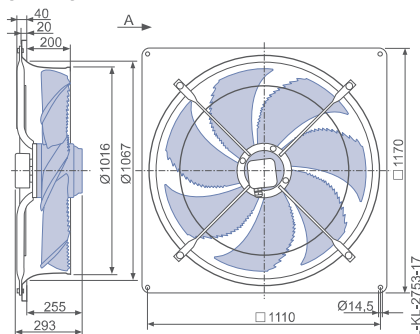

### Airflow direction V

Design S - radially bolted, mounted for short bell mouth, guard grille pressure side

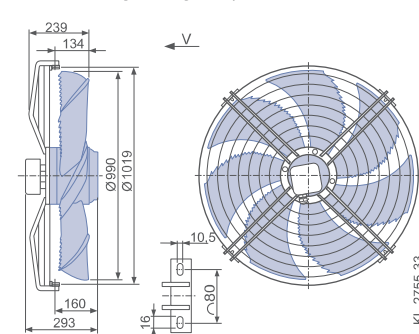

Design I - axial bolted, mounting for bell mouth flange, guard grille pressure side

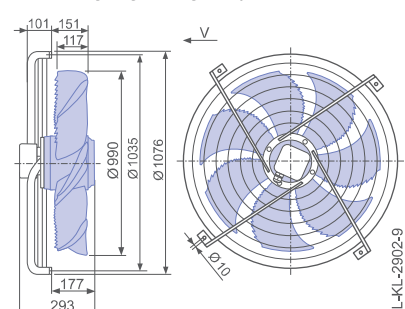

Performance data

Type	Connection	Characteristic curve	Voltage	Operating point	Current	Input power	Speed	Suction side sound power level $L_{WA5}$ dB(A)
			U V					
FN100-AD_7M_5P1	Δ	I	400	①	3.90	2000	670	
			400*	②	3.40*	1550*	690*	82
			400	③	2.90	1150	710	74
	Y	II	400	④	2.40	1350	510	
			400*	⑤	2.00*	1150*	570*	77
			400	⑥	1.60	900	630	70

\*rated data

Fan ordering information

	Airflow direction A	Airflow direction V		
Design	Q (without guard grille)	S (guard grille pressure side)	I (guard grille pressure side)	Q (guard grille pressure side)
Type	FN100-ADQ.7M.A5P1	FN100-ADS.7M.V5P1	FN100-ADI.7M.V5P1	FN100-ADQ.7M.V5P1
Article no.	155848	155852	155850	155851
Weight kg	63.00	48.60	47.80	67.90

Control technology

Frequency inverters Fcontrol 3~	Motor protection units 3~	Electronic voltage controllers 3~
Page 480	Page 518	Page 506

Design Q - square full bell mouth, guard grille pressure side

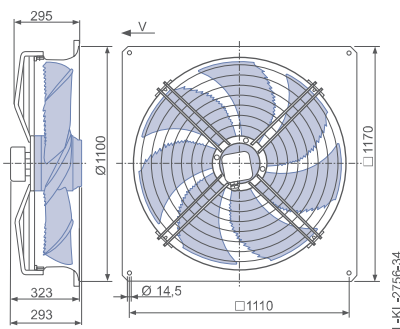

# FE2owlet

for three phase alternating current, 8-8 pole

FN100-AD

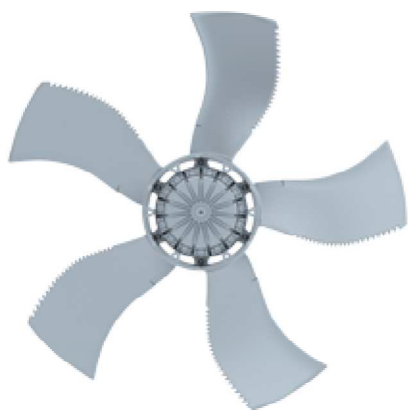

## Description

Motor technology: AC  
 Rated voltage  $U_N$ : 3- 400 V ( $\Delta/Y$ )  $\pm 10$  %\*  
 Rated frequency  $f_N$ : 50 Hz\* (60Hz data available)  
 Input power  $P_i$ : 1.25/0.74 kW\*  
 Rated current  $I_N$ : 2.90/1.40 A\*  
 Rated speed  $n_N$ : 620/ 480  $\text{min}^{-1}$ \*  
 Starting current  $I_s$ : 14.00 / 4.40 A  
 Current increase  $\Delta I$ : 0 %  
 Thermal class: THCL155\*  
 Min. permitted ambient temperature  $t_{R(\text{min})}$ : -40 °C  
 Max. permitted ambient temperature  $t_{R(\text{max})}$ : 70 °C  
 Electrical connection: Terminal box  
 Number of blades: 5  
 Protection class: IP54  
 Motor protection: thermal contact  
 Blades: Aluminium, uncoated  
 Rotor: Aluminium, uncoated  
 Conformity: ErP 2015, CE

**ErP-data**  
 Efficiency  $\eta_{\text{statA}}$ : 34.3 %  
 Efficiency:  $N_{\text{actual}} = 40.2 / N_{\text{target}} = 40$ \*\*  
 \* Rated data  
 \*\*ErP 2015

## Characteristic curve

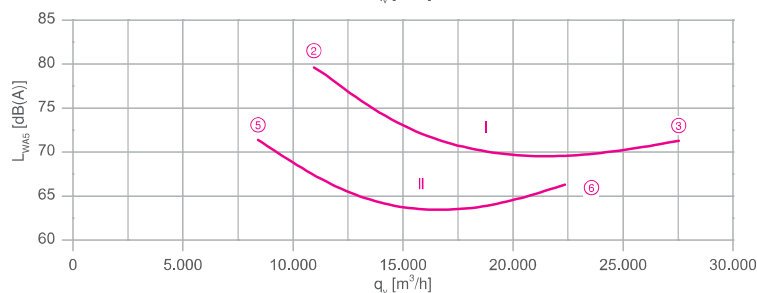
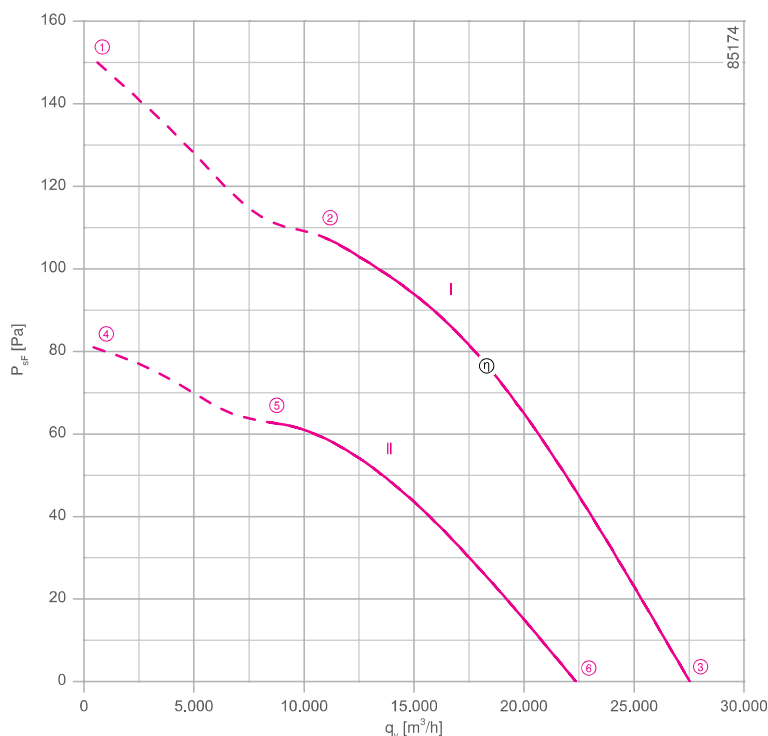

Measured in full bell mouth without guard grille in installation type A according to ISO 5801

Connection diagram Page 531  
 for airflow direction A 1360-108XB  
 for airflow direction V 1360-108XA

System components Page 430

## Dimensions mm

### Airflow direction A

Design Q - square full bell mouth, without guard grille

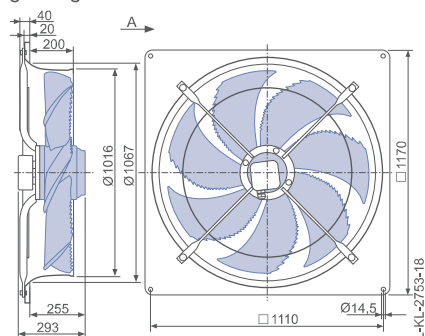

### Airflow direction V

Design S - radially bolted, mounted for short bell mouth, guard grille pressure side

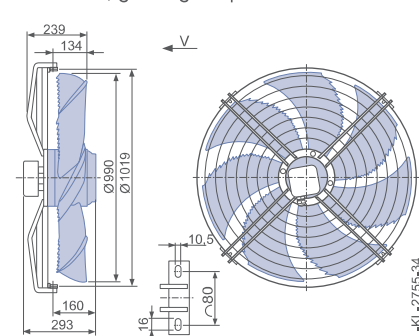

Design I - axial bolted, mounting for bell mouth flange, guard grille pressure side

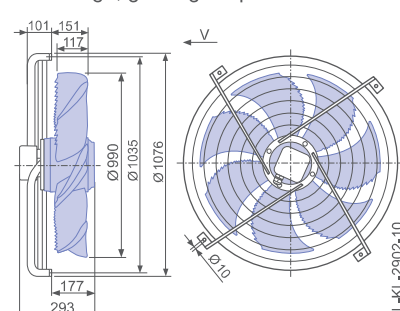



Performance data

Type	Connection	Characteristic curve	Voltage	Operating point	Current	Input power	Speed	Suction side sound power level $L_{WA5}$ dB(A)
			U V					
FN100-AD_7M_5P1	Δ	I	400	①	3.20	1500	590	
			400*	②	2.90*	1250*	620*	80
			400	③	2.70	980	660	71
	Y	II	400	④	1.55	840	430	
			400*	⑤	1.40*	740*	480*	72
			400	⑥	1.20	620	540	66

\*rated data

Fan ordering information

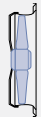
Design	Q (without guard grille)	S (guard grille pressure side)	I (guard grille pressure side)	Q (guard grille pressure side)
				
<b>Type</b>	<b>FN100-ADQ.7M.A5P1</b>	<b>FN100-ADS.7M.V5P1</b>	<b>FN100-ADI.7M.V5P1</b>	<b>FN100-ADQ.7M.V5P1</b>
<b>Article no.</b>	<b>155866</b>	<b>155870</b>	<b>155868</b>	<b>155869</b>
<b>Weight kg</b>	63.00	48.60	47.80	67.90

Control technology

Frequency inverters Fcontrol 3~	Motor protection units 3~	Electronic voltage controllers 3~
		
Page 480	Page 518	Page 506

Design Q - square full bell mouth, guard grille pressure side

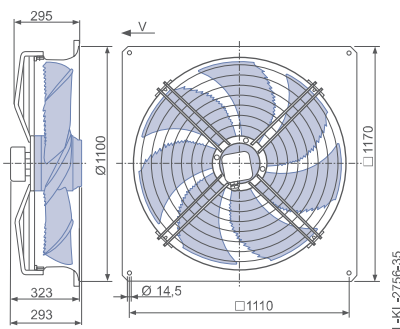

# FE2owlet

for three phase alternating current, 10-10 pole

FN100-MD

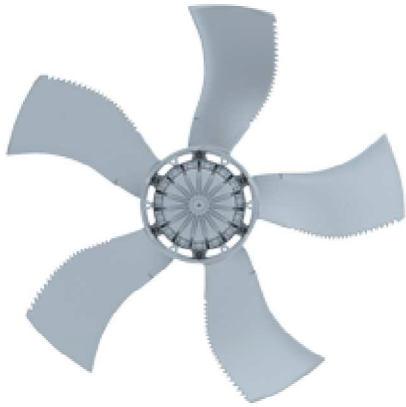

## Description

Motor technology: AC  
 Rated voltage  $U_N$ : 3- 400 V ( $\Delta/Y$ )  $\pm 10$  %\*  
 Rated frequency  $f_N$ : 50 Hz\* (60Hz data available)  
 Input power  $P_i$ : 0,88/0,62 kW\*  
 Rated current  $I_N$ : 2,50/1,25 A\*  
 Rated speed  $n_N$ : 550/ 460  $\text{min}^{-1}$ \*  
 Starting current  $I_s$ : 8,00 / 2,20 A  
 Current increase  $\Delta I$ : 0 %  
 Thermal class: THCL155\*  
 Min. permitted ambient temperature  $t_{R(\text{min})}$ : -40 °C  
 Max. permitted ambient temperature  $t_{R(\text{max})}$ : 70 °C  
 Electrical connection: Terminal box  
 Number of blades: 5  
 Protection class: IP54  
 Motor protection: thermal contact  
 Blades: Aluminium, uncoated  
 Rotor: Aluminium, uncoated  
 Conformity: ErP 2015, CE  
**ErP-data**  
 Efficiency  $\eta_{\text{statA}}$ : 33,4 %  
 Efficiency:  $N_{\text{actual}} = 40,1 / N_{\text{target}} = 40$ \*\*  
 \* Rated data  
 \*\*ErP 2015

## Characteristic curve

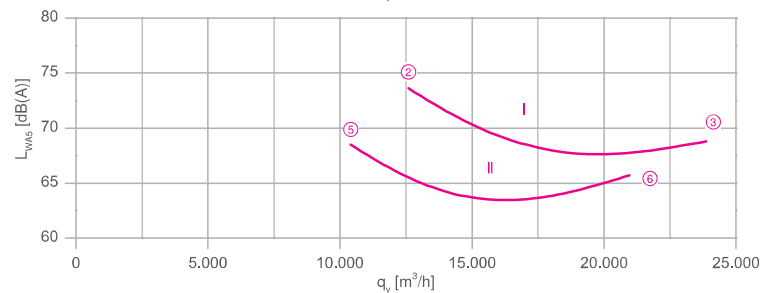
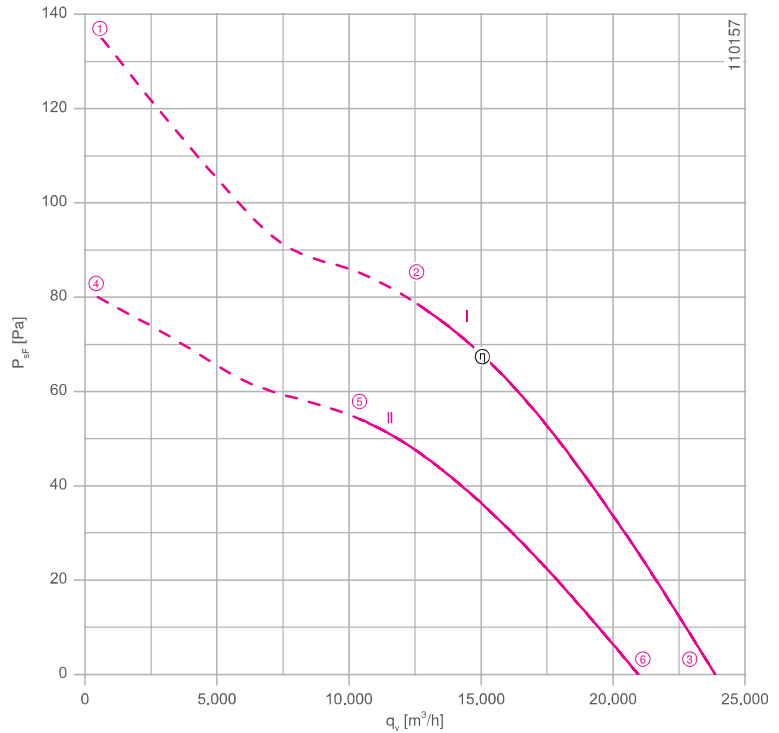

Measured in full bell mouth without guard grille in installation type A according to ISO 5801

Connection diagram Page 531  
 for airflow direction A 1360-108XB  
 for airflow direction V 1360-108XA

System components Page 430

## Dimensions mm

### Airflow direction A

Design Q - square full bell mouth, without guard grille

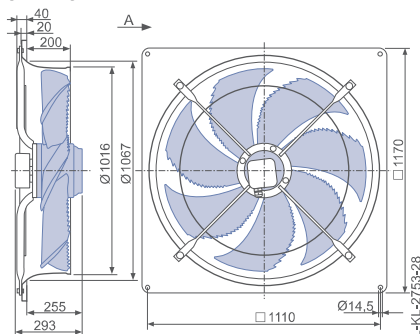

### Airflow direction V

Design S - radially bolted, mounted for short bell mouth, guard grille pressure side

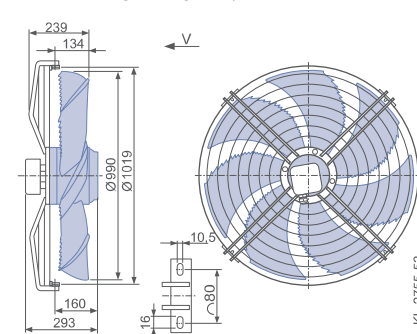

Design I - axial bolted, mounting for bell mouth flange, guard grille pressure side

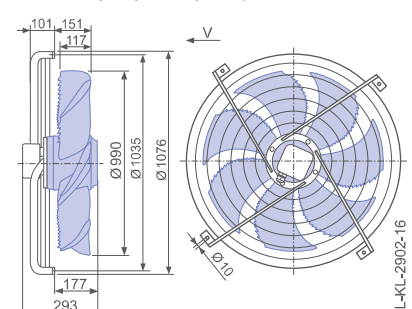

Performance data

Type	Connection	Characteristic curve	Voltage	Operating point	Current	Input power	Speed	Suction side sound power level $L_{WA5}$ dB(A)
			U V					
FN100-MD_7M_5P1	Δ	I	400	①	2.80	1100	540	
			400*	②	2.50*	880*	550*	74
			400	③	2.40	680	570	68
	Y	II	400	④	1.45	700	420	
			400*	⑤	1.25*	600*	460*	69
			400	⑥	1.05	480	500	66

\*rated data

Fan ordering information

Design	Q (without guard grille)	S (guard grille pressure side)	I (guard grille pressure side)	Q (guard grille pressure side)
<b>Type</b>	FN100-MDQ.7M.A5P1	FN100-MDS.7M.V5P1	FN100-MDI.7M.V5P1	FN100-MDQ.7M.V5P1
<b>Article no.</b>	167942	167937	167936	167938
<b>Weight kg</b>	63.00	48.60	47.80	67.90

Control technology

Frequency inverters Fcontrol 3~ 	Motor protection units 3~ 	Electronic voltage controllers 3~ 
Page 480	Page 518	Page 506

Design Q - square full bell mouth, guard grille pressure side

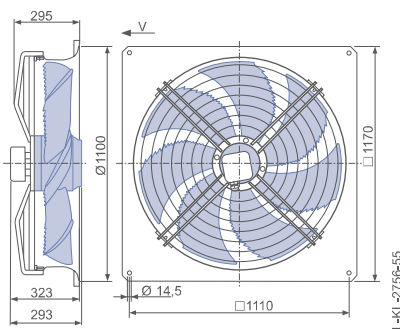



# FE2owlet

for three phase alternating current, 12-12 pole

FN100-ND

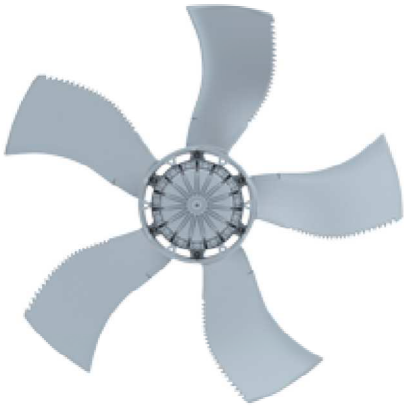

## Description

Motor technology: AC  
 Rated voltage  $U_N$ : 3- 400 V ( $\Delta/Y$ )  $\pm 10$  %\*  
 Rated frequency  $f_N$ : 50 Hz\* (60Hz data available)  
 Input power  $P_i$ : 0.50/0.33 kW\*  
 Rated current  $I_N$ : 1.40/0.70 A\*  
 Rated speed  $n_N$ : 450/370 min<sup>-1</sup>\*  
 Starting current  $I_s$ : 3.80 / 1.20 A  
 Current increase  $\Delta I$ : 0 %  
 Thermal class: THCL155\*  
 Min. permitted ambient temperature  $t_{R(min)}$ : -40 °C  
 Max. permitted ambient temperature  $t_{R(max)}$ : 70 °C  
 Electrical connection: Terminal box  
 Number of blades: 5  
 Protection class: IP54  
 Motor protection: thermal contact  
 Blades: Aluminium, uncoated  
 Rotor: Aluminium, uncoated  
 Conformity: ErP 2015, CE  
**ErP-data**  
 Efficiency  $\eta_{statA}$ : 32.1 %  
 Efficiency:  $N_{actual} = 40.4 / N_{target} = 40$ \*\*  
 \* Rated data  
 \*\*ErP 2015

## Characteristic curve

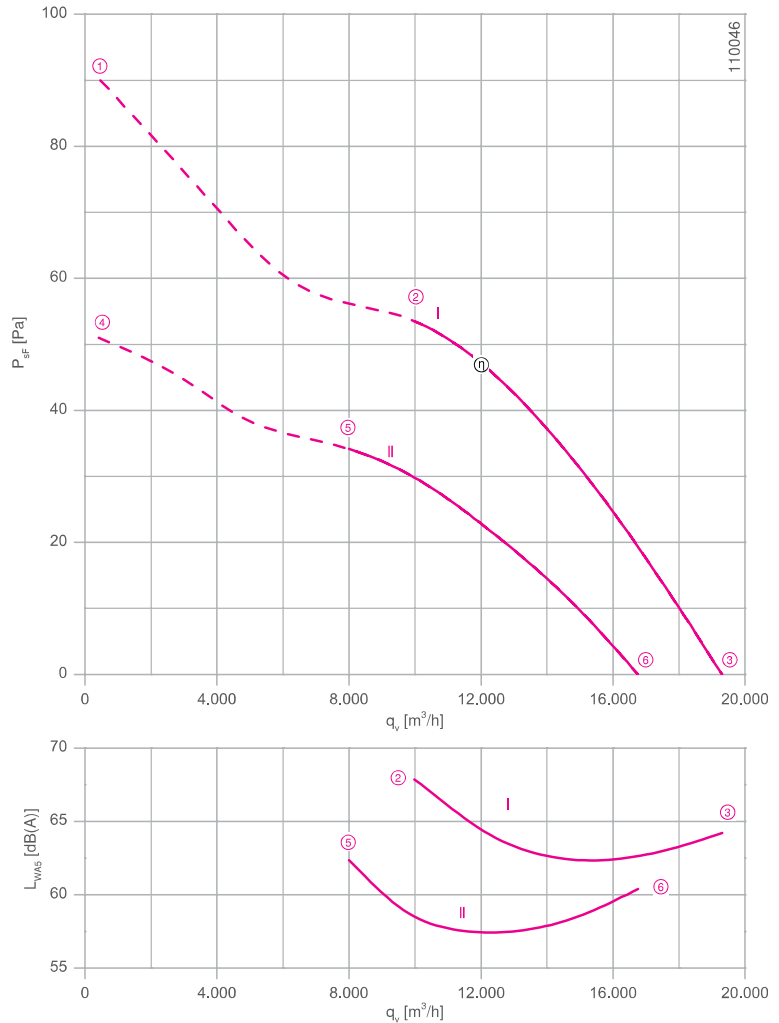

Measured in full bell mouth without guard grille in installation type A according to ISO 5801

Connection diagram Page 531  
 for airflow direction A 1360-108XB  
 for airflow direction V 1360-108XA

System components Page 430

## Dimensions mm

### Airflow direction A

Design Q - square full bell mouth, without guard grille

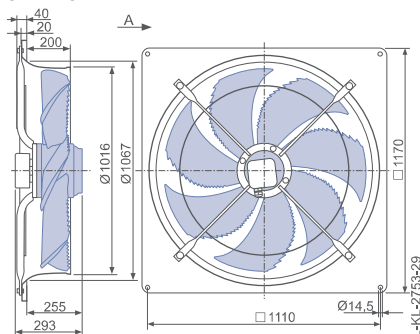

### Airflow direction V

Design S - radially bolted, mounted for short bell mouth, guard grille pressure side

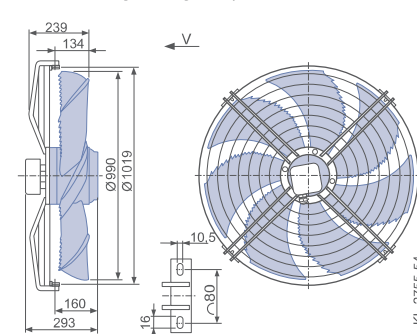

Design I - axial bolted, mounting for bell mouth flange, guard grille pressure side

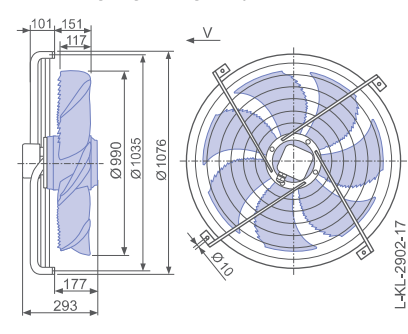

Performance data

Type	Connection	Characteristic curve	Voltage	Operating point	Current	Input power	Speed	Suction side sound power level $L_{WA5}$ dB(A)
			U V					
FN100-ND_7M_5P1	Δ	I	400	①	1.55	600	440	
			400*	②	1.40*	500*	450*	68
			400	③	1.35	380	470	64
	Y	II	400	④	0.78	370	340	
			400*	⑤	0.70*	330*	370*	63
			400	⑥	0.60	270	410	60

\*rated data

Fan ordering information

Design	Q (without guard grille)	S (guard grille pressure side)	I (guard grille pressure side)	Q (guard grille pressure side)
<b>Type</b>	<b>FN100-NDQ.7M.A5P1</b>	<b>FN100-NDS.7M.V5P1</b>	<b>FN100-NDI.7M.V5P1</b>	<b>FN100-NDQ.7M.V5P1</b>
<b>Article no.</b>	<b>167940</b>	<b>160994</b>	<b>167932</b>	<b>167934</b>
<b>Weight kg</b>	63.00	48.60	47.80	67.90

Control technology

Frequency inverters Fcontrol 3~ 	Motor protection units 3~ 	Electronic voltage controllers 3~ 
Page 480	Page 518	Page 506

Design Q - square full bell mouth, guard grille pressure side

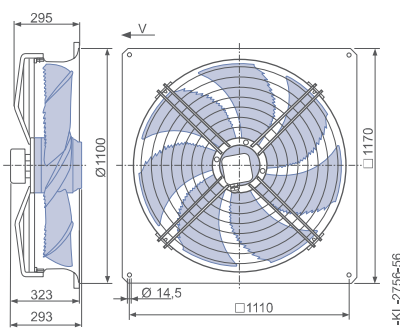

# FE2owlet

for three phase alternating current, 10-10 pole

FN125-MD



## Description

Motor technology: AC  
 Rated voltage  $U_N$ : 3- 400 V ( $\Delta/Y$ )  $\pm 10$  %\*  
 Rated frequency  $f_N$ : 50 Hz\*  
 Input power  $P_i$ : 1.95/1.20 kW\*  
 Rated current  $I_N$ : 4.60/2.40 A\*  
 Rated speed  $n_N$ : 530/ 400  $\text{min}^{-1}$ \*  
 Starting current  $I_s$ : 14.00 / 4.00 A  
 Current increase  $\Delta I$ : 0 %  
 Thermal class: **THCL155\***  
 Min. permitted ambient temperature  $t_{R(\text{min})}$ : -40 °C  
 Max. permitted ambient temperature  $t_{R(\text{max})}$ : 65 °C  
 Electrical connection: Terminal box  
 Number of blades: 3  
 Protection class: IP54  
 Motor protection: thermal contact  
 Blades: Aluminium, uncoated  
 Rotor: Aluminium, uncoated  
 Conformity: ErP 2015, CE  
**ErP-data**  
 Efficiency  $\eta_{\text{statA}}$ : 35.9 %  
 Efficiency:  $N_{\text{actual}} = 40.5 / N_{\text{target}} = 40$ \*\*  
 \* Rated data  
 \*\*ErP 2015

## Characteristic curve

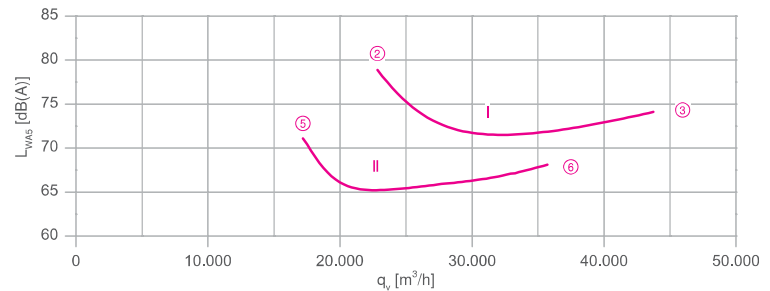
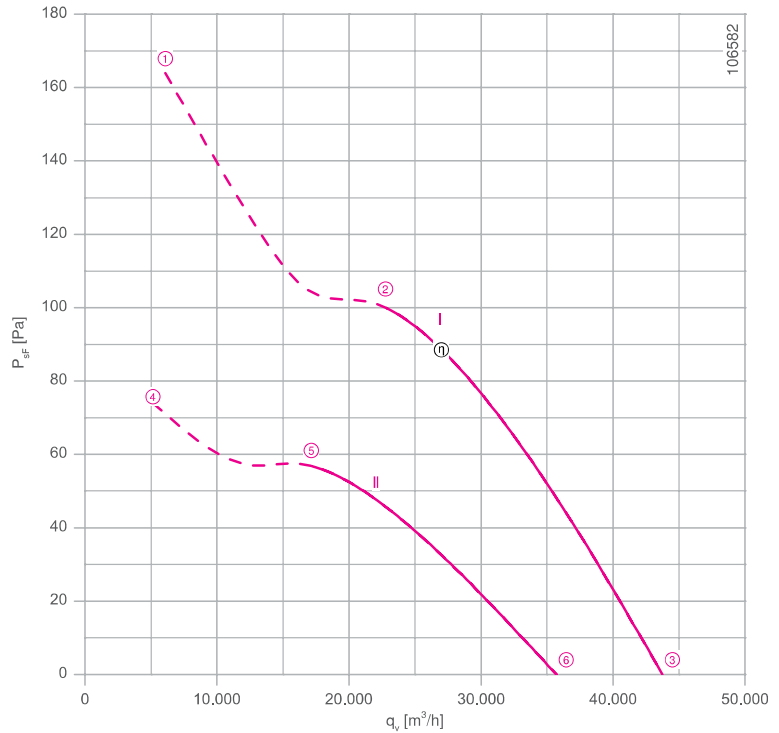

Measured in full bell mouth without guard grille in installation type A according to ISO 5801

Connection diagram Page 531  
 for airflow direction A 1360-108XB  
 for airflow direction V 1360-108XA

System components Page 430

## Dimensions mm

### Airflow direction A

Design F - flange ring with two flanges, without guard grille

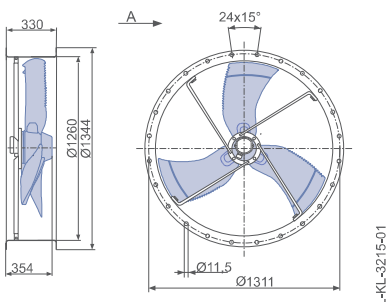

Design L - round full bell mouth, without guard grille

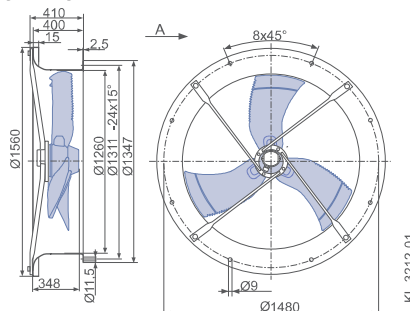

### Airflow direction V

Design I - axial bolted, mounting for bell mouth flange, guard grille pressure side

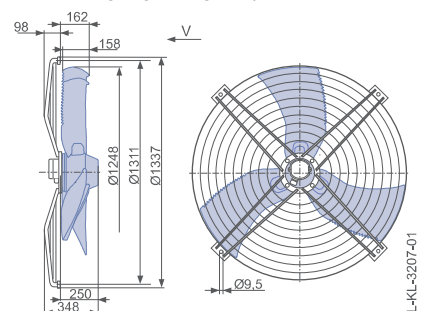

Performance data

Type	Connection	Characteristic curve	Voltage	Operating point	Current	Input power	Speed	Suction side sound power level $L_{WA5}$ dB(A)
			U V					
FN125-MD_7Q_3P1	Δ	I	400	①	5.40	2500	500	
			400*	②	4.60*	1950*	530*	79
			400	③	4.20	1550	550	74
	Y	II	400	④	2.70	1300	340	
			400*	⑤	2.40*	1200*	400*	71
			400	⑥	2.10	1000	450	68

\*rated data

Fan ordering information

	Airflow direction A		Airflow direction V		
Design	F (without guard grille)	L (without guard grille)	I (guard grille pressure side)	L (guard grille pressure side)	L (guard grille two-sided)
Type	FN125-MDF.7Q.A3P1	FN125-MDL.7Q.A3P1	FN125-MDI.7Q.V3P1	FN125-MDL.7Q.V3P1	FN125-MDL.7Q.V3P1
Article no.	167460	167461	167459	167452	167453
Weight kg	86,90	101,00	61,40	106,10	113,70

Control technology

Frequency inverters Fcontrol 3~ 	Motor protection units 3~ 	Electronic voltage controllers 3~ 
Page 480	Page 518	Page 506

Design L - round full bell mouth, guard grille pressure side

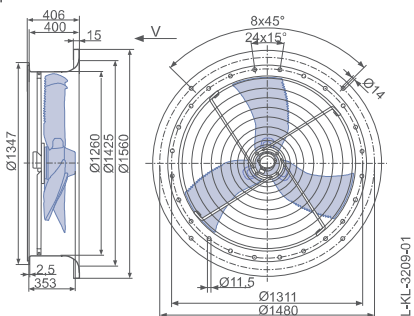

Design L - round full bell mouth, guard grille two-sided

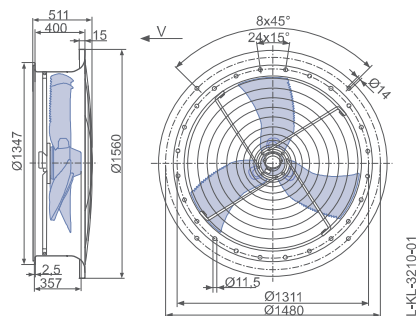

# FE2owlet

for three phase alternating current, 12-12 pole

FN125-ND



## Description

Motor technology: AC  
 Rated voltage  $U_N$ : 3- 400 V ( $\Delta/Y$ )  $\pm 10$  %\*  
 Rated frequency  $f_N$ : 50 Hz\* (60Hz data available)  
 Input power  $P_i$ : 1.15/0.70 kW\*  
 Rated current  $I_N$ : 3.10/1.50 A\*  
 Rated speed  $n_N$ : 440/ 330  $\text{min}^{-1}$ \*  
 Starting current  $I_s$ : 7.50 / 2.40 A  
 Current increase  $\Delta I$ : 0 %  
 Thermal class: THCL155\*  
 Min. permitted ambient temperature  $t_{R(\text{min})}$ : -40 °C  
 Max. permitted ambient temperature  $t_{R(\text{max})}$ : 70 °C  
 Electrical connection: Terminal box  
 Number of blades: 3  
 Protection class: IP54  
 Motor protection: thermal contact  
 Blades: Aluminium, uncoated  
 Rotor: Aluminium, uncoated  
 Conformity: ErP 2015, CE  
**ErP-data**  
 Efficiency  $\eta_{\text{statA}}$ : 34.5 %  
 Efficiency:  $N_{\text{actual}} = 40.6 / N_{\text{target}} = 40$ \*\*  
 \* Rated data  
 \*\*ErP 2015

## Characteristic curve

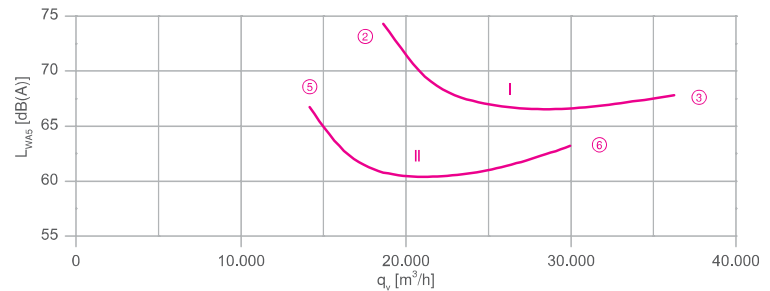
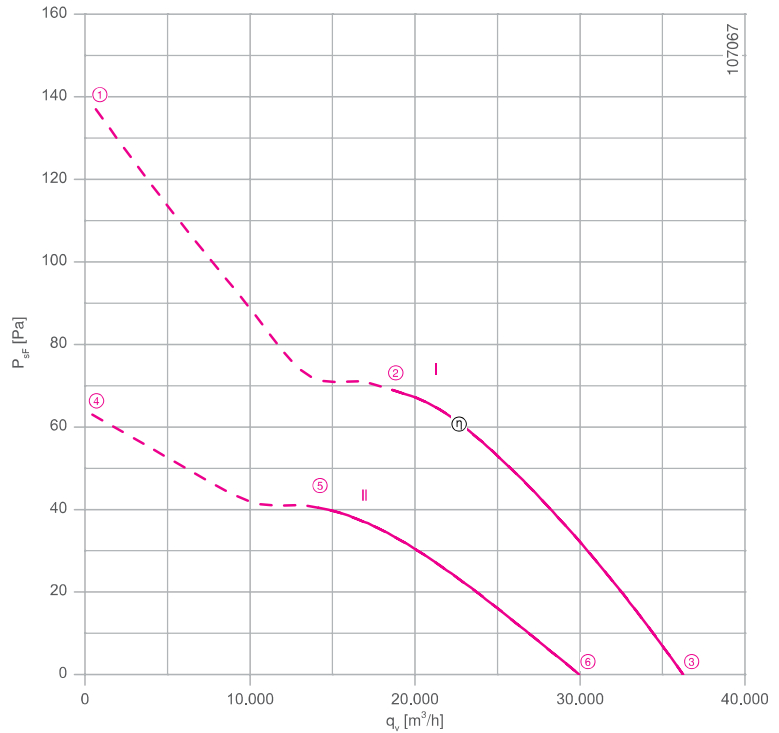

Measured in full bell mouth without guard grille in installation type A according to ISO 5801

Connection diagram Page 531  
 for airflow direction A 1360-108XB  
 for airflow direction V 1360-108XA

System components Page 430

## Dimensions mm

### Airflow direction A

Design F - flange ring with two flanges, without guard grille

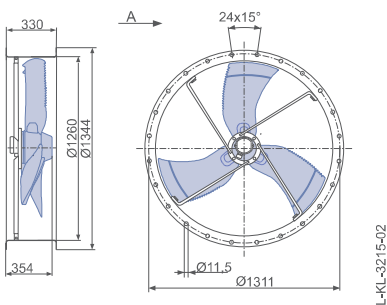

Design L - round full bell mouth, without guard grille

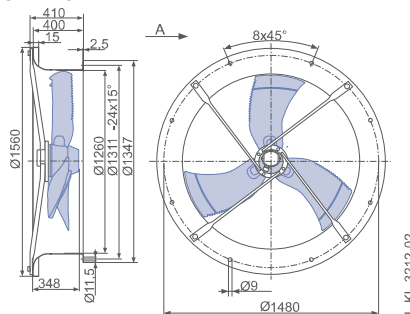

### Airflow direction V

Design I - axial bolted, mounting for bell mouth flange, guard grille pressure side

